

Switches and Multiplexers Portfolio

Analog Devices offers a large range of switches and multiplexers covering single to multiple switch elements, with various signal ranges, and in a variety of packages to best suit customer application needs.

Analog Devices switches can be classified into families when choosing based on supply voltage. High voltage switches are optimized when using the maximum signal range but are specified for use at lower voltages also. The following families of parts exist:

ADG52xx *New*

- Latch-up immune under all conditions, high ESD, lowest leakage at temperature in ± 15 V class
- Operational up to ± 22 V dual supply and +40 V single supply
- Optimized for robustness and precision operation

ADG54xx *New*

- Latch-up immune under all conditions, highest ESD in the ± 15 V class
- Operational up to ± 22 V dual supply and +40 V single supply
- Optimized for robustness and precision operation

ADG14xx

- Lowest R_{ON} in ± 15 V class; minimum distortion and high continuous current
- Min $1 \Omega R_{ON}$, $0.2 \Omega R_{ON}$ flatness

ADG12xx

- Lowest Q_{INJ} and capacitance in ± 15 V class
- < 1 pC Q_{INJ} , 2 pF off capacitance

ADG13xx

- ± 15 V R_{ON} and Q_{INJ} optimized
- Optimized for standard performance applications

ADG5xx

- ± 15 V and ± 5 V low Q_{INJ} and capacitance
- $R_{ON} = 30 \Omega$ to 280Ω , $Q_{INJ} = 4$ pC to 11 pC;
- ADG5xxF ± 15 V with overvoltage/fault protection -40 V to $+55$ V

ADG4xx

- ± 15 V low R_{ON} and low Q_{INJ} ; $R_{ON} = 4 \Omega$ to 50Ω , $Q_{INJ} = 1$ pC to 20 pC
- ADG4xxF ± 15 V with overvoltage/fault protection -40 V to $+55$ V

ADG2xx

- ± 15 V low Q_{INJ} and capacitance
- $R_{ON} = 30 \Omega$ to 115Ω , $Q_{INJ} = 10$ pC to 20 pC

ADG46xx

- ± 5 V power off protection with overvoltage -5.5 V to $+16$ V
- Optimized for robustness and protection

ADG16xx

- Lowest R_{ON} in ± 5 V class; minimum distortion and high continuous current
- Min $1 \Omega R_{ON}$, $0.2 \Omega R_{ON}$ flatness

ADG6xx

- ± 5 V low R_{ON} and low Q_{INJ}
- $R_{ON} = 2 \Omega$ to 85Ω , $Q_{INJ} = 0.5$ pC to 50 pC

ADG8xx

- < 5.5 V ultralow R_{ON} and minimum distortion and high continuous current
- $R_{ON} = 0.25 \Omega$ to 0.8Ω , 0.05Ω to $0.17 \Omega R_{ON}$ flatness

ADG7xx

- < 5.5 V low R_{ON}
- $R_{ON} = 2.2 \Omega$ to 15Ω , $Q_{INJ} = 2$ pC to 14 pC

ADG9xx

- Low voltage dc to high frequency RF
- -3 dB BW = 2.5 GHz to 4.5 GHz

ADG3xxx

- Low voltage level translators/bus switches
- Unidirectional and bidirectional digital

ADG21xx

- Unbuffered crosspoint switches
- Dual and single supply I²C controlled

Enhanced Product and Automotive Parts

- Please contact ADI technical support and Sales for details

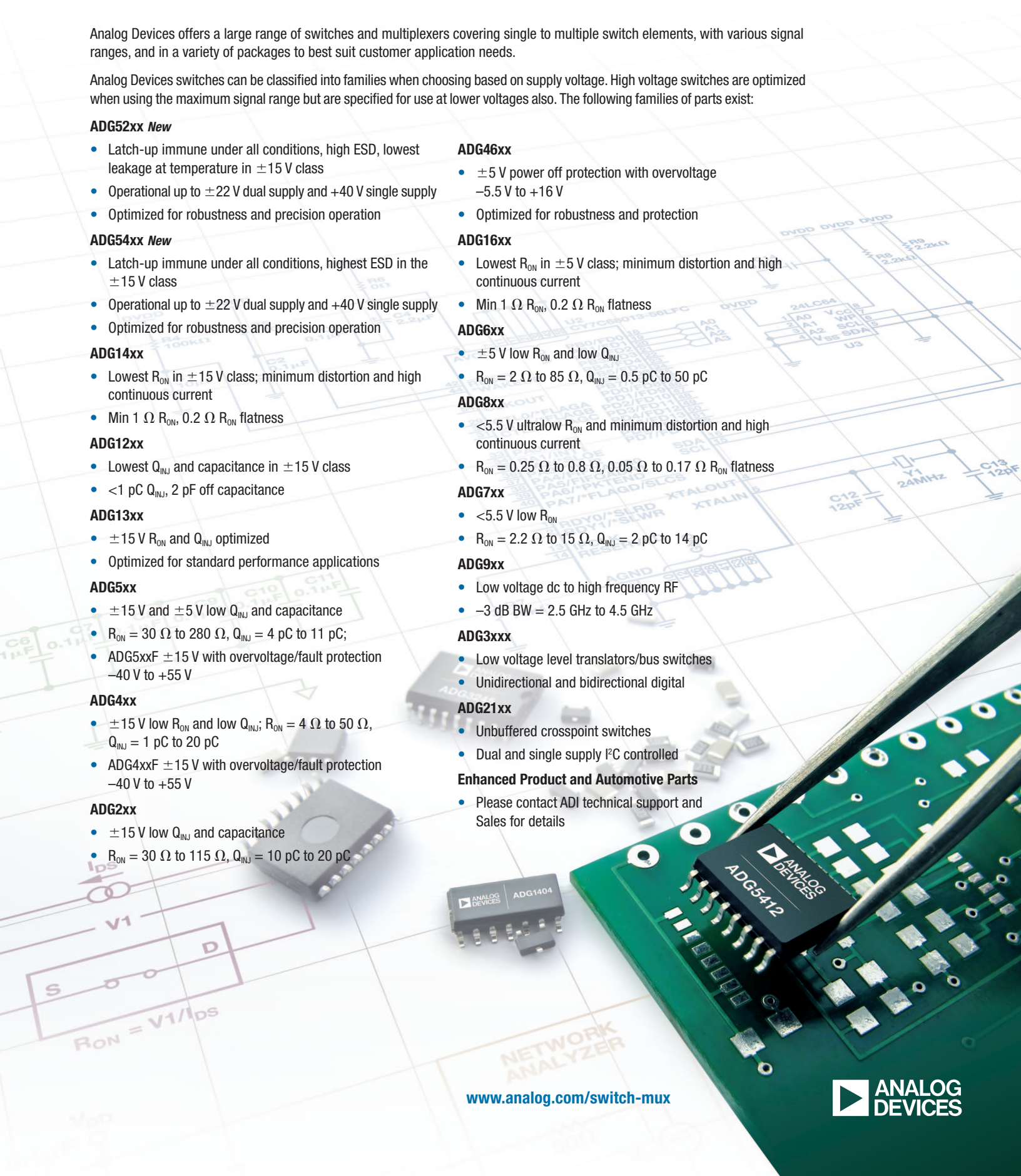

Part Number	Function	Specifications				Characterization Voltages (V _{NOM})				Interface	Packaging								
		R _{ON} Typ (Ω)	On Leakage Typ (nA)	Q _{INJ} Typ (pC)	BW (MHz)	Single			Dual ±2.5		TSSOP	LFCSP	SOIC	SOT/SOT-8	MSOP	QSOP	WLCSP	TOFP	SC70
						+1.65 to +3.6	+2.7 to +5.5	+1.8 to +5.5											
<i><5.5 V Analog (continued)</i>																			
ADG824	SPDT × 2	0.5	0.2	27	90	•				Parallel	•								
ADG836/ADG836L	SPDT × 2	0.5	0.2	40	57	•				Parallel	•			•					
ADG854	SPDT × 2	0.8	0.03	30	100			•		Parallel	•								
ADG736/ADG736L	SPDT × 2	2.5	0.01		200			•		Parallel				•					
ADG787	SPDT × 2	2.5	0.05	14	145			•		Parallel	•			•					
ADG772	SPDT × 2	6.7	0.2	0.5	630	•				Parallel	•								
ADG733	SPDT × 3	2.5	0.01	3	160			•	•	Parallel	•				•				
ADG786	SPDT × 3	2.5	0.01	3	160			•	•	Parallel	•								
ADG858	SPDT × 4	0.58	0.01	45	70			•		Parallel	•								
ADG774	SPDT × 4	2.2	0.01	7	240			•		Parallel		•		•					
ADG784	SPDT × 4	2.2	0.01	10	240			•		Parallel	•								
ADG774A	SPDT × 4	2.2	0.001	6	400			•		Parallel	•			•					
ADG734	SPDT × 4	2.5	0.01	3	160			•	•	Parallel	•								
ADG788	SPDT × 4	2.5	0.01	3	160			•	•	Parallel	•								
ADG794	SPDT × 4	5	0.001	6	300		•			Parallel				•					
ADG790	SPDT × 4/diff 4:1 mux	5.9/3.9	10	0.57/6.2	550/230	•				Parallel					•				
ADG888	DPDT × 2	0.4	0.2	70	29			•		Parallel	•	•			•				
ADG804	4:1 mux	0.5	0.1	28	33	•				Parallel				•					
ADG704	4:1 mux	2.5	0.01	3	200			•		Parallel				•					
ADG728/ADG729	8:1/diff 4:1 mux	2.5	0.01	3	65/100		•			I ² C	•								
ADG738/ADG739	8:1/diff 4:1 mux	2.5	0.01	3	65/100		•			SPI	•								
ADG708/ADG709	8:1/diff 4:1 mux	3	0.01	3	55			•	•	Parallel	•								
ADG758/ADG759	8:1/diff 4:1 mux	3	0.01	3	55			•	•	Parallel	•	•							
ADG706/ADG707	16:1/diff 8:1 mux	2.5	0.01	5	25/36			•	•	Parallel	•								
ADG726/ADG732	32:1/diff-dual 16:1 mux	4	0.05	5	34/18			•	•	Parallel	•						•		
ADG725/ADG731	32:1/diff-dual 16:1 mux	4	0.05	5	34/18			•	•	SPI	•						•		

Part Number	Function	Specifications				Characterization Voltages (V _{NOM})						Level Translation	Packaging							
		R _{ON} Typ (Ω)	Propagation Delay Max (ps)	Bus Enable Typ (ns)	Data Rate (Mbps)	Single				Dual			TSSOP	LFCSP	SOT/SOT-8	MSOP	QSOP	DIE	WLCSP	SC70
						+1.15 to +5.5	+1.65 to +3.6	+2.3 to +3.6	+3.3 to +5.0	0 to -24.2	+10.8 to +35									
<i>Bus Switches/Level Translators</i>																				
ADG3241	1-bit bidirectional	4.5	225	3.2	1500			•				Down							•	
ADG3242	2-bit bidirectional	4.5	225	3.2	1500			•				Down					•			
ADG3243	2-bit bidirectional	4.5	225	3.2	1500			•				Down			•					
ADG3245	8-bit bidirectional	4.5	225	3.2	1244			•				Down	•	•						
ADG3246	10-bit bidirectional	4.5	225	3.2	1244			•				Down	•							
ADG3247	16-bit bidirectional	4.5	225	3.2	1244			•				Down		•						
ADG3248	1-bit 2:1 bidirectional	4.5	225	3.2	1244			•				Down							•	
ADG3257	4-bit 2:1 bidirectional	2	100	5	933					•		Down				•				
<i>Level Translators</i>																				
ADG3231	1-bit unidirectional	N/A	4000	N/A				•				Up/down				•				
ADG3233	1-bit bypass unidirectional	N/A	3500	4				•				Up/down				•	•			
ADG3123	8-bit CMOS to HV unidirectional	N/A	8000		0.2					•	•	Up	•							
ADG3301	1-bit bidirectional	N/A	5000	1000	50	•						Up/down							•	
ADG3304	4-bit bidirectional	N/A	5000	1000	50	•						Up/down	•	•					•	
ADG3300	8-bit bidirectional	N/A	5000	1000	50	•						Up/down	•							
ADG3308/ADG3308-1	8-bit bidirectional	N/A	5000	1000	50	•						Up/down	•	•					•	

Part Number	Function	Specifications			Characterization Voltages (V _{NOM})		Interface	Packaging		
		Off Isolation	Insertion Loss	Power (dBm)	-3 dB BW (MHz)	Single		TSSOP	LFCSP	MSOP
<i>Low Voltage, DC to High Frequency RF</i>										
ADG901/ADG902	SPST × 1	37 dB (1 GHz)	0.8 dB (1 GHz)	17	4500	+1.65 to +2.75	Parallel		•	•
ADG918/ADG919	SPDT × 1	37 dB (1 GHz)	0.8 dB (1 GHz)	17	4000	+1.65 to +2.75	Parallel		•	•
ADG936/ADG936-R	SPDT × 2	36 dB (1 GHz)	0.9 dB (1 GHz)	16	4000	+1.65 to +2.75	Parallel	•	•	
ADG904/ADG904-R	4:1 mux	37 dB (1 GHz)	1.1 dB (1 GHz)	16	2500	+1.65 to +2.75	Parallel	•	•	

Choosing the Correct Switch or Multiplexer for Your Application

Supply voltage, configuration, specifications, and package are the key requirements in choosing the correct switch/mux for your application. As an individual switch cannot be optimized in all respects, Analog Devices offers a large and varied selection of options that cover differing supply voltages and configurations, high performance, and industry-leading package sizes.

Supply Voltage

Depending on the supply voltage that you require, Analog Devices can offer you a number of high performance switches and multiplexers that suit your application. Low voltage switches can offer performance advantages over higher voltage switches. High voltage switches are optimized when using the maximum signal range but are specified for use at lower voltages also. Analog Devices offers a varied range of supply voltages from:

- ± 15 V
- ± 5 V
- Low voltage (up to 5 V)
- Single and dual supply options

If, for example, you are using a 5 V power supply in your circuit and require a switch, then the best switch to choose would be one of our low voltage (<5 V) switches and not one of our high voltage (± 15 V) parts. Likewise, if you require high voltage operation, then the ± 15 V will be optimized for operation at these voltages and the performance will degrade as the voltage is reduced.

Configuration

Do you need a switch or a multiplexer? If a switch, do you need an SPST (single pole, single throw) or an SPDT (single pole, double throw)? How many channels do you need? Do you need a bus switch or level translator (for digital signals)? What interface do you require?

- I²C: 2-wire digital interface; SCL (clock) and SDA (data)
- SPI: 3-wire serial interface; FSYNC, DATA, SCLK
- Parallel: simple digital interface; logic high/low on the pin dictates the state of the switch
- SPI and I²C offers the advantage of reducing the number of digital pins required when using switches/muxes of large array size

Specifications

Parameter	Definition	Indicator
Supply voltage	Voltage of the analog switch circuit	Must be bigger than signal amplitude
R _{ON} (on resistance)	Resistance of the closed switch path	Lower is better
On leakage	Leakage currents into/out of a switch channel	Lower is better
Q _{inj} (charge injection)	Disturbance to signal from control input	Lower is better
BW (bandwidth)	Frequency range of the switch in the on state where the switch attenuates the input signal by 3 dB	Higher is better
Off isolation	Transfer function of the switch when in the off state	Higher is better
Insertion loss	Transfer function of the switch when in the on state	Lower is better
Power	Maximum signal power the switch can pass in the on state	Higher is better
Propagation delay	Time required for signal to travel through switch	Lower is better
Bus enable	Time required to enable or disable the bus switch	Lower is better
Data rate	Speed of data that the switch/mux can handle	Higher is better

Package

All Analog Devices switches are offered in a number of different package options, offering in some cases up to 75% saving on board space vs. the nearest competitor. Details of these package types and information on package sizes can be seen on the back page of this guide.

Other Requirements

Do you require a switch/mux optimized for robustness and protection with latch-up immunity, power-off protection (with overvoltage), or overvoltage protection? *Latch-up immune* means that latch-up will not occur regardless of the power sequence to the device. *Power-off protection* means the device is guaranteed in a high impedance off state with no power supplies present. *Overvoltage protection* means the switch is guaranteed to withstand specified voltages on the analog inputs which exceed the supplies.

Do you require enhanced product (typically used for military/aerospace applications) or automotive qualified (AECQ-100) parts? Please contact ADI technical support and sales for details.

Technical Support and Sales

Applications engineers are available by phone or email to discuss any queries with regard to any of our switches. Details can be found on our website www.analog.com. Samples are available for all our switches and can be requested through your local ADI representative.

Examples of Some of the Package Types Available

Package	Lead Count Options	Example Body Size (mm)	Example Board Area (sq mm)	Example Pitch (mm)	Package Code
TSSOP	14/16/20/24/28/38	5.0 × 4.4 × 0.65 (14-lead)	32 (14-lead)	0.65 (14-lead)	RU-X ²
MSOP	8/10	3.0 × 3.0 × 1.1 (8-lead)	14.7 (8-lead)	0.65 (8-lead)	RM-X ²
LFCSP	8/10/12/16/20/ 24/32/40/48	3.0 × 3.0 × 0.9 (8-lead)	9 (8-lead)	0.65 (8-lead)	CP-X ²
SOT-23	5/6/8	2.9 × 1.6 × 1.175 (5-lead)	8.12 (5-lead)	0.95 (5-lead)	RT/RJ-X ²
SC70	5/6	1.25 × 2.0 × 0.65 (5-lead)	4.2 (5-lead)	0.65 (5-lead)	KS-X ²
SOT-66	6	1.66 × 1.2 × 0.57 (6-lead)	2.74 (6-lead)	0.5 (6-lead)	RY-X ²
Mini LFCSP	10/16	1.3 × 1.6 × 0.6 (10-lead)	2.08 (10-lead)	0.4 (10-lead)	CP-X ²
WLCSP ¹	5/6/10/12/16	0.9 × 1.29 × 0.5 (5-ball)	1.16 (5-ball)	0.5 (5-ball)	CB-X ²

¹Dimensions dependent by part.
²"-X" denotes number of leads.

Common Switch and Multiplexer Configurations

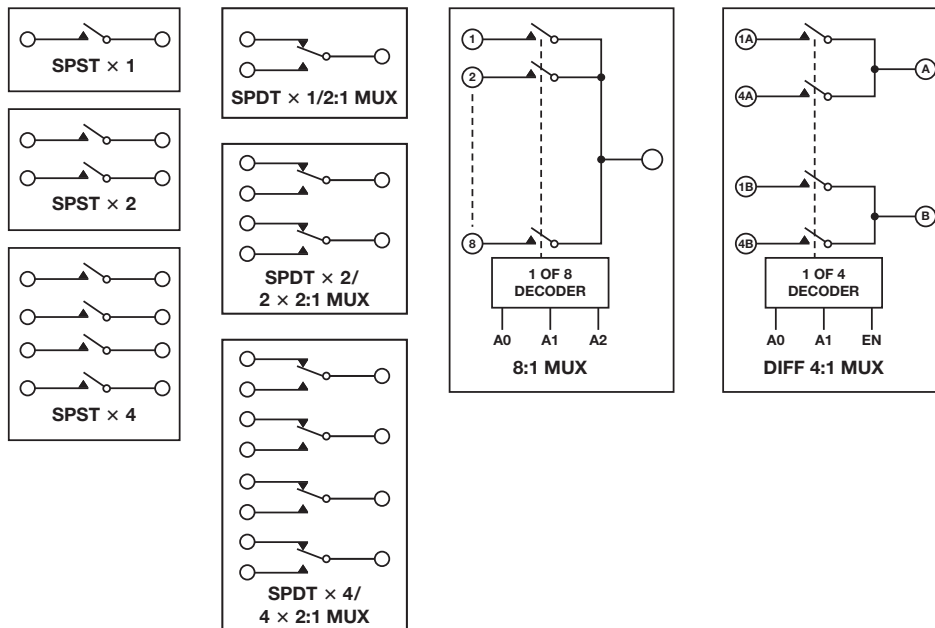

For more information on ADI switches and multiplexers, visit our website at www.analog.com/switch-mux.

Analog Devices, Inc. Worldwide Headquarters

Analog Devices, Inc.
One Technology Way
P.O. Box 9106
Norwood, MA 02062-9106
U.S.A.

Tel: 781.329.4700
(800.262.5643,
U.S.A. only)
Fax: 781.461.3113

Analog Devices, Inc. Europe Headquarters

Analog Devices, Inc.
Wilhelm-Wagenfeld-Str. 6
80807 Munich
Germany
Tel: 49.89.76903.0
Fax: 49.89.76903.157

Analog Devices, Inc. Japan Headquarters

Analog Devices, KK
New Pier Takeshiba
South Tower Building
1-16-1 Kaigan, Minato-ku,
Tokyo, 105-6891
Japan
Tel: 813.5402.8200
Fax: 813.5402.1064

Analog Devices, Inc. Asia Pacific Headquarters

Analog Devices
5F, Sandhill Plaza
2290 Zuchongzhi Road
Zhangjiang Hi-Tech Park
Pudong New District
Shanghai, China 201203
Tel: 86.21.2320.8000
Fax: 86.21.2320.8222

¹PC refers to a communications protocol originally developed by Philips Semiconductors (now NXP Semiconductors).

©2013 Analog Devices, Inc. All rights reserved. Trademarks and registered trademarks are the property of their respective owners.

ST03729-0-10/13(E)

