



INTRODUCTION TO TRANSFORMER MAGNETICS

G022.A (7/99)

CONTENTS

- 1.0 INTRODUCTION

- 2.0 FUNDAMENTAL TRANSFORMER MAGNETICS
 - 2.1 Faraday's Law
 - 2.2 The Ideal Transformer
 - 2.3 Magnetic Flux Density
 - 2.4 Magnetizing Force
 - 2.5 Material Permeability
 - 2.6 The B/H Curve
 - 2.7 Relative Permeability
 - 2.8 Reluctance
 - 2.9 Self Inductance
 - 2.10 Mutual Inductance
 - 2.11 Coupling Coefficient
 - 2.12 Symbol Dot Convention
 - 2.13 Impedance Transformation
 - 2.13.1 *Transformation of parallel impedance.*
 - 2.13.2 *Transformation of series impedance*
 - 2.14 Effect of Air Gap in Core
 - 2.14.1 *Core Saturation*

- 3.0 TRANSFORMER EQUIVALENT CIRCUIT
 - 3.1 Finite Permeability
 - 3.2 Core Losses
 - 3.2.1 *Hysteresis Loss*
 - 3.2.2 *Eddy current Loss*
 - 3.2.3 *Core Loss Resistance*
 - 3.3 Winding Resistances
 - 3.4 Leakage Flux
 - 3.5 Distributed Capacitance
 - 3.6 Inter-winding Capacitance
 - 3.7 Combined Equivalent Circuit

- 4.0 TRANSFORMER APPLICATIONS
 - 4.1 Transformer as Isolation Element
 - 4.2 Transformer as Impedance Matching Element
 - 4.3 Common Mode Chokes

5.0 TRANSFORMER TESTS

5.1 Open Circuit Test

5.2 Short Circuit Test

6.0 FREQUENCY RESPONSE CHARACTERISTICS

6.1 Low Frequency Response

6.2 High Frequency Response

6.3 Operating Frequency Response

7.0 TIME DOMAIN RESPONSE CHARACTERISTICS

7.1 Pulse Rising Edge Response

7.2 Pulse Peak Response

7.3 Pulse Falling Edge Response

APPENDIX 1 GLOSSARY OF MAGNETIC TERMS

APPENDIX 2 MAGNETIC MATERIALS

1.0 INTRODUCTION

The designer of Telecommunications or Local Area Networking (LAN) equipment will frequently be faced with the use of transformers as part of an analogue interface or physical layer section of their circuit. The primary use of transformers in this type of application is as an impedance matching and/or isolation device, serving as a barrier between external cables and internal digital circuitry.

This PULSE Application Note is intended for designers who are less familiar with the use and characteristics of digital signal transformers, but who would like a basic understanding of the relevant underlying physical principles and how they affect the transformer performance.

The first main section of the note explains the fundamental theory of transformer magnetics, and explains the meaning and interpretation of the principle magnetic parameters. Where possible a physical interpretation of the theory is given in addition to the mathematical formulae.

The Note next develops a general equivalent circuit which can be used to model transformer behaviour. Within this section explanations are given of the various terms and parameters which are used in the specification of transformers.

Transformer applications are dealt with in the next section, followed by a description of transformer tests used to measure the transformer equivalent circuit parameters .

In order to gain an understanding of how a real transformer behaves in use, the general equivalent circuit model is used to derive the frequency-domain characteristics of a wide-band signal transformer in the case of simple resistive source and load.

Time-domain performance is dealt with finally with an explanation of how the equivalent circuit parameters affect the rising edge, peak and trailing edge characteristics of an applied pulse waveform. The response of a transformer to pulse waveforms is of particular interest in LAN and Telecommunications applications where data signals take the form of high repetition rate digital pulses.

Appendix 1 is a glossary of terminology used in connection with magnetic products.

Appendix 2 lists common magnetic materials used in transformer core construction with a brief description of their properties.

2.0 FUNDAMENTAL TRANSFORMER MAGNETICS

2.1 FARADAY'S LAW

Electricity and Magnetism are closely related to each other. A magnetic field is the result of the movement of electric charge (i.e. current), and conversely if a conductor is placed in a time-varying magnetic field, an electromotive force (emf) is induced in the conductor which causes current to flow. The emf is proportional to the rate of change of magnetic flux and is given by Faraday's Law.

$$\text{[equation 1]} \quad e = -\frac{d\psi}{dt} = -N\frac{d\phi}{dt}$$

where e = induced emf (unit : V)
 N = Number of turns on winding
 t = time (unit : s)
 ϕ = magnetic flux (unit : Wb)
 ψ = flux linkage (unit : Wb)

An ideal transformer operates by transferring electrical energy from its input winding, via a magnetic field, to its output winding according to Faraday's Law.

2.2 THE IDEAL TRANSFORMER

Figure 1 shows a simplified transformer with primary and secondary windings of turns ratio 1:n. Note that source and load are not shown for clarity.

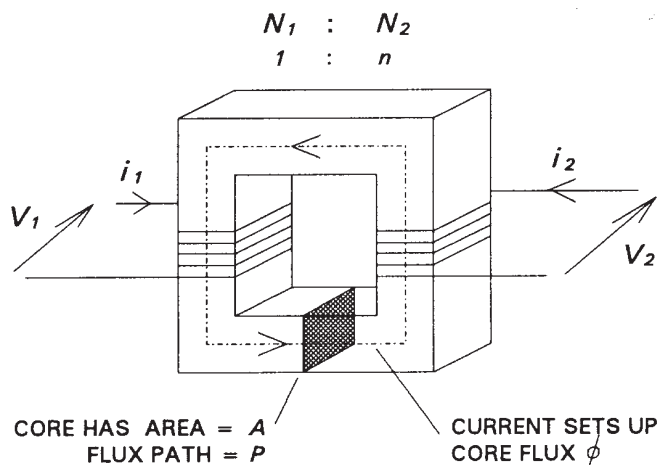

FIGURE 1 - IDEAL TRANSFORMER

The primary applied voltage V_1 (time varying) causes a current i_1 to flow in the primary winding. The current gives rise to a core flux ϕ which we will assume is entirely contained in the core and passes completely through the secondary windings. We also assume that there are no losses of any kind. The core flux ϕ induces a voltage across the secondary winding V_2 and a current i_2 .

Expressing the above in terms of Faraday's Law (equation 1) ...

$$V_1 = -N_1 \frac{d\phi}{dt} \quad \text{and} \quad V_2 = -N_2 \frac{d\phi}{dt}$$

$$\text{[equation 2]} \quad \frac{V_1}{V_2} = \frac{N_1}{N_2} = \frac{1}{n}$$

2.3 MAGNETIC FLUX DENSITY

In the ideal transformer of Figure 1 the core flux ϕ is contained completely within a core of cross sectional area A . The Magnetic Flux Density (symbol B) within the core is defined as ...

[equation 3]
$$B = \frac{\phi}{A}$$
 (unit : Wb/m²)

2.4 MAGNETIZING FORCE

The Magnetizing Force (symbol H) applied to a transformer is the amount of electrical energy required to produce a given magnetic flux density in the transformer core.

AMPÈRES LAW states that ...

[equation 4]
$$NI = \sum_{i=1}^{\infty} H_i \cdot l_i$$
 (unit : A)

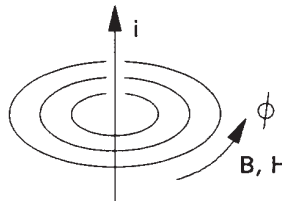

i.e. the sum around a magnetic circuit of the product of discrete Magnetizing Force and Flux path length at a given current equals the applied Ampere-Turns (or applied electrical energy).

For an ideal coil the $\sum = HP$ as i is constant ($i = I$) at all points in the coil, so that ...

[equation 5]
$$H = \frac{NI}{P}$$
 (unit : A/m)

2.5 MATERIAL PERMEABILITY

Magnetic Flux Density (B) is a function of Magnetizing Current (H). The relationship is ...

[equation 6]
$$B = \mu H$$
 where : μ = Permeability (unit : H/m)

μ is only constant in the case of free space ($\mu = \mu_0 = 4\pi \times 10^{-7}$ H/m). For other materials the $B - H$ relationship follows the general form shown in Figure 2

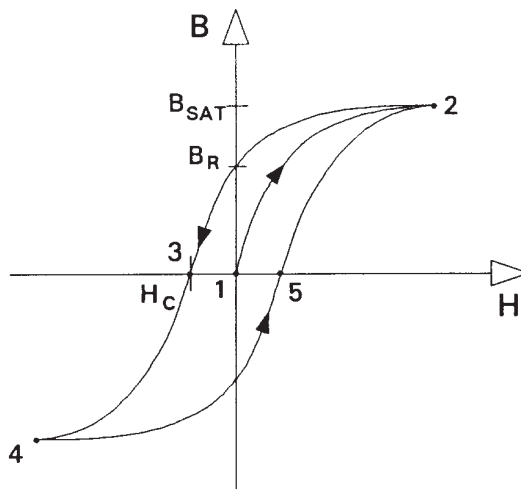

FIGURE 2 - B / H CURVE

2.6 THE B / H CURVE

Figure 2 shows that the $B - H$ curve exhibits hysteresis and that μ can only be considered constant for small increments in B and H .

If an initially unmagnetized material is subjected to an increasing H field the value of B increases according to the section of curve 1-2. The slope of the curve at the point of zero B and H is called the INITIAL PERMEABILITY. As H is increased a point is reached at which B no longer increases. This is point 2 on the curve and is called the SATURATION POINT of the material. $B = B_{SAT}$. Reducing H now results in the curve tracing path 2-3-4. At the point when H again is zero, B has a RESIDUAL value. $B = B_R$. At Point 3, B again equals zero, and the value of reverse H required to achieve this is called the COERCIVE FORCE. $H = H_C$. Point 4 represents saturation with a reversed direction of H . If H is now increased the curve traces section 4-5-2. Note that the curve will not pass again through point 1.

Under pure AC conditions the core is cyclically magnetized, with the curve being traced around loop 2-3-4-5-2 once per cycle.

The hysteresis of the $B-H$ curve is associated with power loss. It can be shown that the losses are proportional to the area of the loop.

2.7 RELATIVE PERMEABILITY

The Relative Permeability of a magnetic material is defined as follows ...

[equation 7]
$$\mu_R = \frac{\mu}{\mu_o}$$
 where μ_R = Relative material permeability
 μ = Absolute material permeability
 μ_o = Permeability of free space

2.8 RELUCTANCE

Applying Equation 4 (Amperes Law) to the ideal transformer of Figure 1, we can write ...

$$NI = N_1 i_1 - N_2 i_2 \quad \text{and} \quad \sum H_i \cdot l_i = HP = \frac{B}{\mu} P = \frac{P}{A\mu} \phi$$

[equation 8]
$$\text{Reluctance} = \mathfrak{R} = \frac{P}{A\mu} \quad (\text{unit : } H^{-1})$$

[equation 9]
$$N_1 i_1 = \phi \mathfrak{R} + N_2 i_2$$

The LHS of equation 9 gives the input Ampere-Turns, while the RHS shows that the useful Ampere-Turns available from the output is reduced by a term proportional to the core reluctance. This term is called the CORE MAGNETIZATION and represents the current necessary to support the magnetic field within the core itself.

For the ideal case when $\mu \rightarrow \infty$ then $\mathfrak{R} \rightarrow 0$ then ...

[equation 10]
$$\frac{i_1}{i_2} = \frac{N_1}{N_2} = n$$

2.9 SELF INDUCTANCE

The Self Inductance of a coil is that inductance which results from the magnetic field generated by the coil current acting on the coil itself. It is defined as follows ...

[equation 11]
$$e = -L \frac{di}{dt}$$

where L = Self Inductance (unit : H)
 e = voltage across inductor (unit : V)
 t = time (unit : s)

Calculation of L for many inductor geometries is rather complicated, as it involves the evaluation of the summation / integral of Ampere's Law to relate H to i . As a simple example we shall now find the inductance of an ideal coil wound on a toroidal core.

From Faraday's Law :-

$$V = -N \frac{d\phi}{dt} = -NA \frac{dB}{dt}$$

so, $V = -NA \mu \frac{dH}{dt}$ (1)

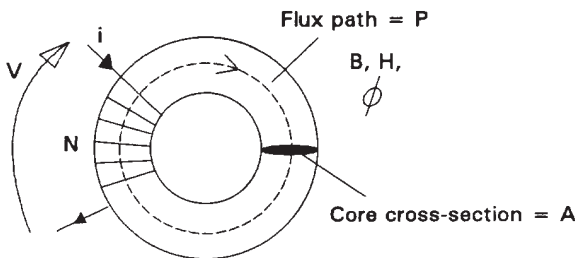

FIGURE 3 - TORIOD WOUND INDUCTOR

From Ampere's Law :-

$$Ni = HP$$
 (2)

Combining (1) and (2) gives :-

$$V = -\frac{N^2 A \mu}{P} \cdot \frac{di}{dt} \quad \text{so, INDUCTANCE is given by } L = \frac{N^2 A \mu}{P}$$

2.10 MUTUAL INDUCTANCE

For transformers and other coupled coils the effect of the magnetic field generated by the secondary (and other) coils on the primary coil must also be considered. The inductance caused by the effect of flux coupling between two coils is called Mutual Inductance.

Let us consider the case of two coils wound on a core. In the general case not all flux links both windings, as shown in Figure 4.

From Ampere's Law we can write ...

$$\begin{aligned} \phi_{12} &= a(N_1 i_1 + N_2 i_2) \\ \phi_{11} &= bN_1 i_1 \\ \phi_{22} &= cN_2 i_2 \end{aligned}$$

where a, b and c represent the actual proportionality constants.

From Faraday's Law we can write ...

$$V_1 = N_1 \frac{d}{dt} \{ \phi_{11} + \phi_{12} \} \quad \text{and} \quad V_2 = N_2 \frac{d}{dt} \{ \phi_{22} + \phi_{12} \}$$

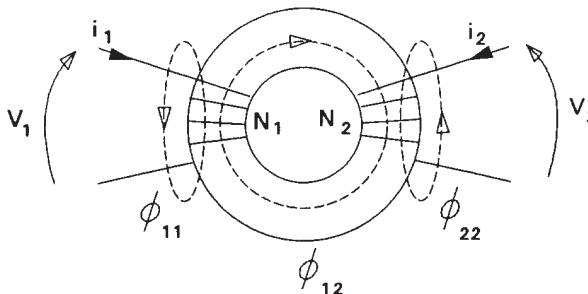

FIGURE 4 - COUPLED COILS

$$V_1 = N_1^2(a+b) \frac{di_1}{dt} + N_1 N_2 a \frac{di_2}{dt} \quad \text{and} \quad V_2 = N_2^2(a+c) \frac{di_2}{dt} + N_1 N_2 a \frac{di_1}{dt}$$

We can write ...

$$L_1 = N_1^2(a+b) = \text{Self Inductance of coil 1}$$

$$L_2 = N_2^2(a+c) = \text{Self Inductance of coil 2}$$

$$M = N_1 N_2 a = \text{Mutual Inductance between the coils}$$

For the perfect case $\phi_{11}, \phi_{22} = 0$ and $b, c = 0$. So for perfectly coupled coils we can say ...

[equation 12] $M = \sqrt{L_1 L_2}$

2.11 COUPLING COEFFICIENT

The realistic case for coupled coils is that not all flux is coupled between the windings. In section 2.10 the constants b and c are no longer zero. One way of expressing how fully the coils are linked is with the Coupling Coefficient of the coils, k ...

[equation 13] $M = k\sqrt{L_1 L_2}$ where $0 \leq k \leq 1$

2.12 SYMBOL DOT CONVENTION

The conventional circuit symbol for a simple transformer is shown in Figure 5 below.

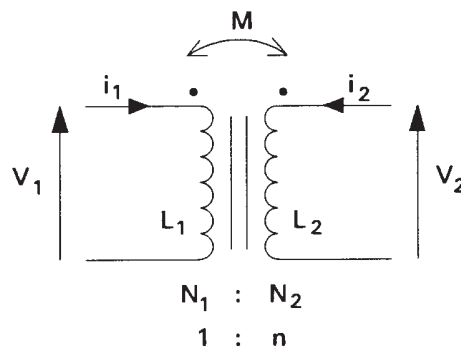

FIGURE 5 - TRANSFORMER CIRCUIT SYMBOL

The dots above each winding are used to indicate the sense of mutual inductance and the winding phase. When the dots are as shown, and the voltages and currents have the conventional sense shown, the transformer equations are written as follows ...

$$V_1 = L_1 \frac{di_1}{dt} + M \frac{di_2}{dt} \quad \text{and} \quad V_2 = L_2 \frac{di_2}{dt} + M \frac{di_1}{dt}$$

If voltages or currents are shown reversed then the sign of the relevant terms must also be reversed.

In practical terms, conventional voltages are shown with +ve towards the dots and currents flow into the windings through the dots.

2.13 IMPEDANCE TRANSFORMATION

When dealing with transformer circuit analysis it is often convenient to transform any impedances on the secondary side of the transformer into equivalent impedances on the primary side. This often simplifies the equivalent circuit.

2.13.1 Transformation of Parallel impedance

It is most convenient to think in terms of the power (P) drawn by the impedance ...

$$P_2 = \frac{V_2^2}{Z_2} \quad \text{but from equation 2 (section 2.2) we have } V_1 = \frac{V_2}{n} \quad \text{so that } P_2 = V_1^2 \cdot \frac{n^2}{Z_2}$$

This is equivalent to placing an impedance across the primary so that $Z_1 = \frac{Z_2}{n^2}$ as shown in Fig. 6

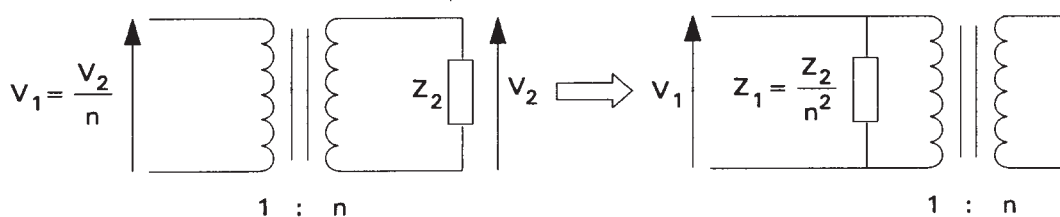

FIGURE 6 - TRANSFORMATION OF PARALLEL IMPEDANCE

2.13.1 Transformation of Series impedance

Again thinking in terms of power drawn by the impedance ...

$$P_2 = i_2^2 Z_2 \quad \text{but from equation 10 (section 2.8) we have } i_1 = n i_2 \quad \text{so that } P_2 = i_1^2 \cdot \frac{Z_2}{n^2}$$

This is equivalent to placing an impedance in series with the primary so that $Z_1 = \frac{Z_2}{n^2}$ as shown in Fig. 7

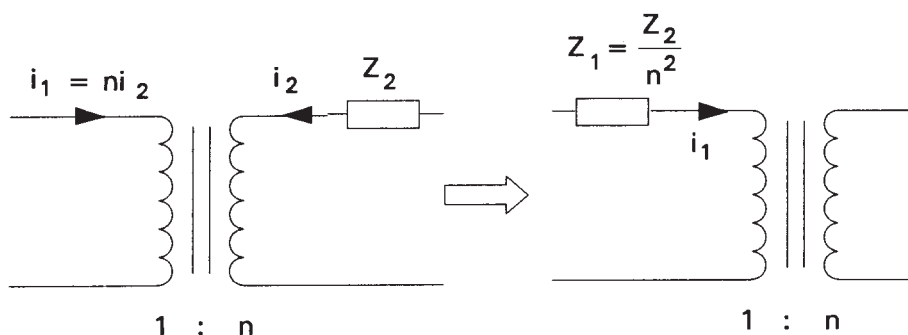

FIGURE 7 - TRANSFORMATION OF SERIES IMPEDANCE

2.14 EFFECT OF AIR GAP IN CORE

FIGURE 8 shows a simplified transformer coil wound on a core with an air gap (exaggerated for clarity). The core material has an equivalent flux path length P and the length of the air gap is p .

If we assume that the gap is small and all flux is perpendicular to the gap boundary (no fringing effects) then the magnetic flux density normal to the boundary between the core material and the air is continuous, so we can write ...

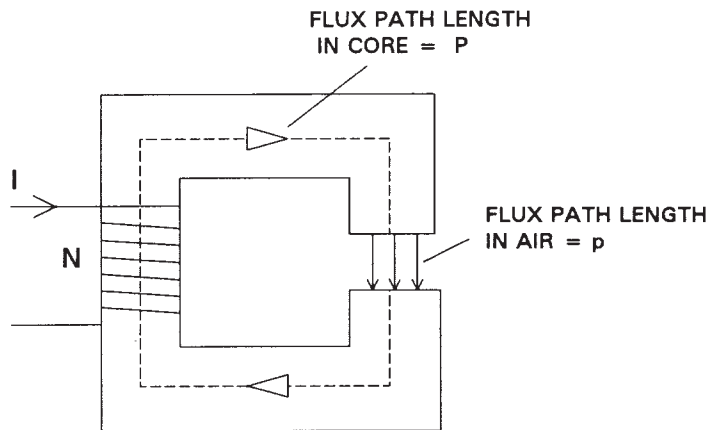

FIGURE 8 - CORE WITH AIR GAP

$$B = \mu_o H_{air} = \mu_o \mu_R H_{core}$$

$$\text{therefore } H_{air} = \mu_R \cdot H_{core} \quad \dots\dots (1)$$

Also from Ampere's Law $NI = H \times \text{path length}$, or ...

$$NI = H_{air} \cdot p + H_{core} \cdot P = H_{core} (\mu_R \cdot p + P) \quad \text{from (1)}$$

$$\text{Rearranging for core field intensity we can write ... } \boxed{H_{core} = \frac{NI}{P} \cdot \left\{ \frac{1}{1 + a\mu_R} \right\}} ; a = \frac{p}{P} \quad (0 \leq a \leq 1)$$

This means that the field intensity within the core is reduced by a factor $1/(1+a\mu_R)$ compared to the case with no air gap (assuming p is small compared to P). It follows that the applied NI required to push the core into saturation is increased by the same factor.

For example ... A ferrite core with an equivalent core flux path length of 5cm, a relative permeability of 5000 and a total air gap length of 0.1mm reaches saturation at an NI value approx. 11 times higher than an equivalent un-gapped core.

Use of air gapped cores is common in Telecommunications applications where there is a DC current flowing in the transformer winding which would otherwise saturate the core. Use of a large gap causes increased fringing effects (so that not all flux is contained within the gap) which in turn increase leakage inductance and stray capacitance.

2.14.1 Core Saturation

As was described in section 2.6 (The B / H curve) all magnetic materials reach a point at which B no longer increases with increasing H . This is the SATURATION point of the material at which $\mu = 0$.

We have seen that $e = -N \frac{d\phi}{dt} = -NA \mu \frac{dH}{dt}$ so that if $\mu = 0$, $e = 0$ and no transformation occurs.

And as $H \propto i$ we know in general that Inductance $\propto \mu$, so that if $\mu = 0$, OCL and Leakage Inductances = 0.

Beyond the saturation point of the core, the transformer ceases to be a transformer at all.

3.0 TRANSFORMER EQUIVALENT CIRCUIT

In section 2.0 we assumed that our transformer was perfect. The assumptions made for an ideal transformer are ...

- (1) The core material has high enough permeability to be considered effectively infinite ($\mu \Rightarrow \infty$).
- (2) Core magnetization current is small enough to be considered effectively zero ($\mathfrak{R} \Rightarrow 0$).
- (3) Any losses in the core are negligibly small.
- (4) The winding resistances of the coils are negligibly small.
- (5) All flux is perfectly coupled between windings with no flux "escaping" ($k = 1$).
- (6) Winding capacitances are negligibly small.

Of course a real transformer will not meet these assumptions, although a well designed one will come very close at its rated current and operating frequency. In the following sections we shall develop a transformer equivalent circuit that includes the effects of all realistic parameters on the ideal transformer. These non-ideal effects play a major part in determining the actual performance of a transformer as we shall see later.

3.1 FINITE PERMEABILITY

If μ is finite, then \mathfrak{R} will be non-zero and a core magnetization current will flow to maintain the core-flux (see section 2.8).

From equations 9 and 10 we can write ...

$$i_1 = \frac{\phi \mathfrak{R}}{N_1} + \frac{N_2}{N_1} i_2 = i_m + \frac{i_2}{n}$$

The current i_m is the core magnetization current, and is in phase with the primary coil current. We can represent this additional current in our equivalent circuit by placing an inductance L_m in parallel with the primary coil as shown in Figure 9.

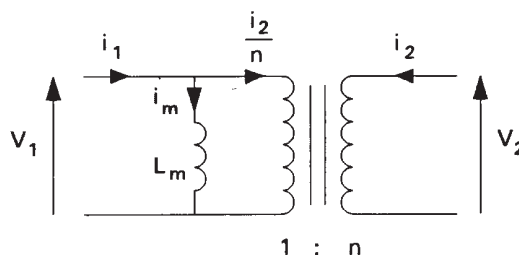

FIGURE 9 - CORE MAGNETIZATION CURRENT

3.2 CORE LOSSES

3.2.1 Hysteresis Loss

Section 2.6 explained that a cyclically magnetized core exhibits a hysteretic relationship between B and H and that the loss associated with this hysteresis can be shown to be proportional to the area enclosed by the curve. The area of the curve is itself proportional to frequency, but at a constant frequency (the rated operating frequency of the transformer - although this is a vague concept for pulse transformers), the hysteresis loss is given by the empirically derived Steinmetz Formula ...

[equation 14]
$$P_h = k_h \cdot B_{\max}^{1.6}$$
 where k_h is a material constant

3.2.2 Eddy current loss

Faraday's Law implies that emf.s are generated around the flux path, which set up loop currents in the core material. The finite resistance of the core results in a power loss. The loss is proportional to frequency squared, but at constant f and uniform flux distribution (two big approximations) ...

[equation 15]
$$P_e = k_e B_{\max}^2$$
 where k_e is a material constant

3.2.3 Core loss resistance

The hysteresis and eddy loss terms can be combined to produce a useful approximation for core loss.

$$p_c = k_h B_{\max}^{1.6} + k_e B_{\max}^2 \approx \alpha \cdot \phi_{\max}^2$$

and ϕ_{\max} is proportional to $V_{1\max}$

so that ...

[equation 16] $p_c \propto V_{1\max}^2$

Although this is rather a loose approximation, it does enable us to model core loss as a resistance R_c in parallel with the primary winding as shown in Fig. 10.

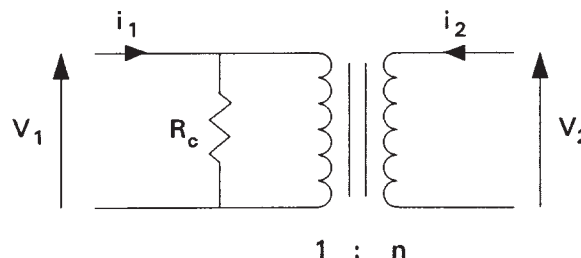

FIGURE 10 - CORE LOSS RESISTANCE

To reduce core losses we can either use a material with a high resistivity (e.g. ferrite materials) or use a core construction type that impedes the flow of eddy currents (e.g. laminated iron cores)

3.3 WINDING RESISTANCES

The wire which is used to wind the transformer coils will have a non-zero resistance, which will cause ohmic losses in each of the windings. Including this effect in the equivalent circuit simply requires series resistance to be added to each coil as shown in Figure 11.

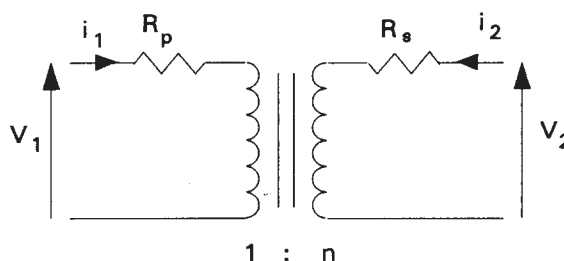

FIGURE 11 - WINDING RESISTANCE

To reduce winding losses we can either use wire with a larger diameter or minimise the number of turns.

3.4 LEAKAGE FLUX

We showed in Section 2.10 that for the general case of not all flux completely linking both coils (i.e. there is some "leakage flux") the self inductance of the coils can be written as ...

$$L_1 = N_1^2(a+b) \quad \text{and} \quad L_2 = N_2^2(a+c)$$

Considering first the primary.

The term aN_1^2 can be thought of as the ideal self inductance of the coil ignoring leakage flux, with the term bN_1^2 representing the effect of the leakage flux. (i.e. the "LEAKAGE INDUCTANCE"). So to include the effect of leakage flux in the equivalent circuit, we can add an inductance in series with the ideal primary coil as shown in Figure 12 above. The same reasoning applies equally to the secondary coil.

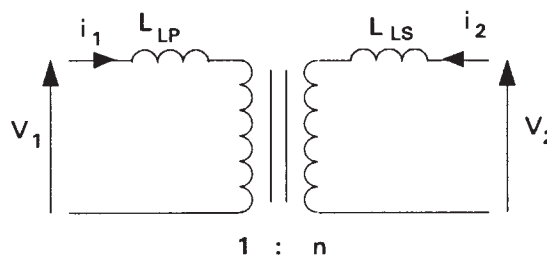

FIGURE 12 - LEAKAGE INDUCTANCE

Factors affecting the magnitude of leakage inductance include winding technique and core geometry.

3.5 DISTRIBUTED CAPACITANCE

There exist several sources of parasitic capacitance in a real transformer winding. The most significant is the capacitance that appears across a winding due to coupling between the coil wire and the transformer core. The size of this capacitance depends on the winding geometry and the dielectric constants of the core material and other packaging materials (e.g. epoxy used in device encapsulation or PTFE tape used for inter-winding isolation).

A Secondary capacitance effect is caused by the capacitance between a coil turn and adjacent turns, although this effect is usually small as the turn-turn capacitances sum in series (thus the overall capacitance is reduced) rather than in parallel. To model this distributed winding capacitance we add a lumped capacitance across each ideal coil in the transformer equivalent circuit as shown in Figure 13.

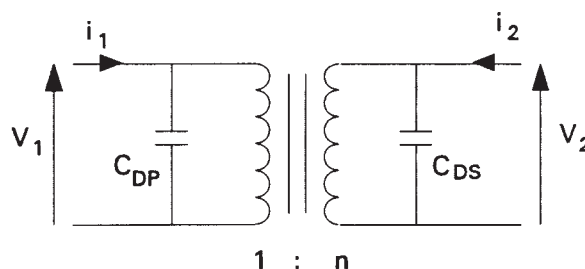

FIGURE 13 - DISTRIBUTED CAPACITANCE

3.6 INTER-WINDING CAPACITANCE

The proximity of primary and secondary windings in a transformer gives rise to a capacitance between the windings (C_{WW} in Figure 14). The size of this capacitance depends on the winding geometry and the dielectric constants of the transformer core material and other packaging materials. Usually this capacitance is very small in comparison with the transformer inductance, and its effect will only be seen at frequencies rather higher than the upper cut-off frequency of the transformer (see later explanation of transformer frequency response).

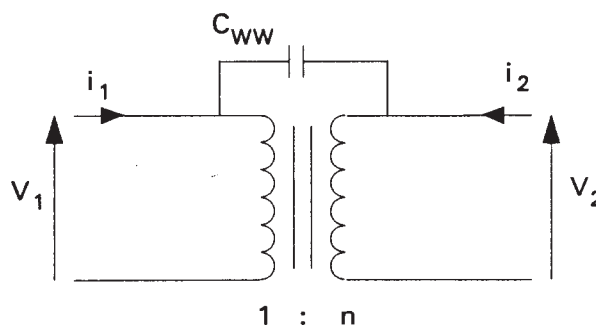

FIGURE 14 - INTER-WINDING CAPACITANCE

3.7 COMBINED EQUIVALENT CIRCUIT

Combining all the non-ideal factors described in sections 3.1 to 3.6, we obtain the general equivalent transformer circuit shown in Figure 15.

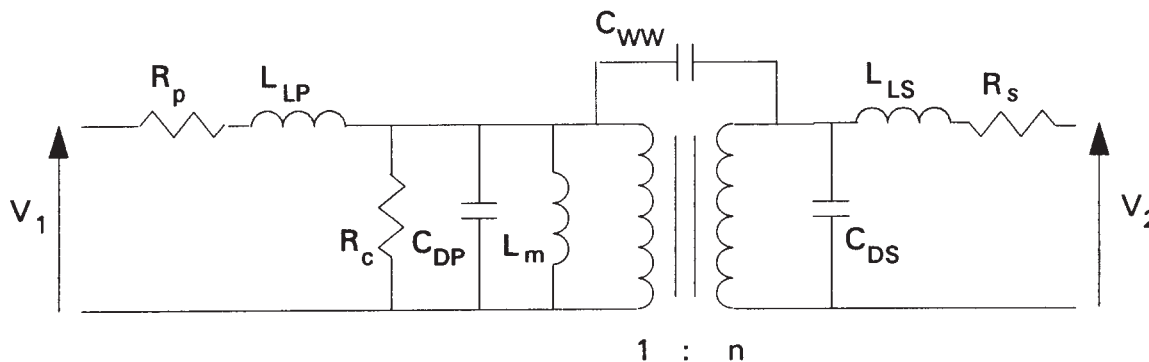

FIGURE 15 - GENERAL TRANSFORMER EQUIVALENT CIRCUIT

4.0 TRANSFORMER APPLICATIONS

Although there are many applications for transformers within the broad field of electrical and electronic engineering, for LAN and Telecommunications applications the two main uses of signal transformers are as isolation elements and as a means of matching dissimilar source and load impedances. Although not strictly a transformer application, common mode chokes are sufficiently related to transformers in their mode of operation that a brief explanation is also included in this section. Chokes find widespread use as noise suppressers in LAN and Telecom applications using twisted pair cable.

4.1 TRANSFORMER AS ISOLATION ELEMENT

The signal transformer is designed to pass signals within a certain range of frequencies and amplitudes with tolerable distortion. In LAN and Telecommunications applications digital circuitry must be protected from certain external electrical hazards such as 60Hz/120V or 50Hz/230V AC mains, 50V telephone ring signal and lightning strikes which may conceivably be connected to the external interfaces.

Placing a transformer between the output circuitry and interface provides an electrical connection for signals within the transformers working frequency range, but none for signals outside this range. For LAN and Telecommunications applications the working frequency range may be anything between 10kHz and 100MHz (roughly speaking).

High voltage mains signals at 50/60Hz are sufficiently low frequency not to be passed by the interface signal transformer. Of course depending on the transformer construction and power rating the secondary windings may or may not be damaged by the application of mains voltages. The key point is that the primary winding remains unaffected either indefinitely or for a tolerable period of time before damage occurs.

In the case of lightning strikes the secondary winding will usually be destroyed, but so long as electrical isolation of the primary is maintained the purpose is fulfilled.

4.2 TRANSFORMER AS IMPEDANCE MATCHING ELEMENT

We saw in section 2.13 how load impedances may be transformed from the secondary side of the transformer circuit to the primary side, so long as the impedance is multiplied by a factor $1/n^2$. This property enables a transformer to be used to match dissimilar source and load impedances.

To match source to load we would like

$$Z_{IN} = Z_{SOURCE}$$

We know from section 2.13 that the equivalent impedance seen across the primary (equals Z_{IN}) is

$$Z_{IN} = \frac{Z_{LOAD}}{n^2}$$

Therefore input and output will be matched if ...

[equation 17]
$$n = \sqrt{\frac{Z_{LOAD}}{Z_{SOURCE}}}$$

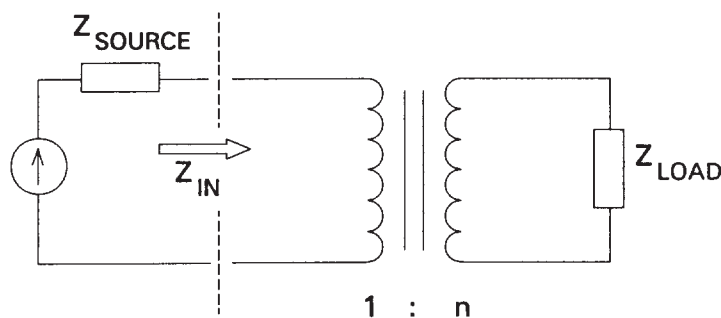

FIGURE 16 - TRANSFORMER IMPEDANCE MATCHING

4.3 COMMON MODE CHOKES

Common mode chokes are similar to transformers in that they work by the coupling of magnetic fields generated by closely coupled coils wound on a common core. They differ from transformers in that they are not used to transfer or isolate signals, but rather to present a high impedance to common-mode signals while allowing differential mode signals to pass unhindered.

Figure 17 shows a common mode voltage present on the inputs of a choke. The reference level is arbitrary. The voltages and currents present on each line are equal (the current return path is not shown, but in reality is usually via stray capacitances back to the reference level).

The two windings have a 1 : 1 turns ratio and are wound on the same core so that in the ideal case all flux is inter-linked (same as ideal transformer).

Both common-mode currents flow in the same direction and produce in phase additive core flux.

The effect of this is that each signal sees a series inductive impedance, the magnitude of which depends on frequency and the coil parameters (such as core permeability, cross section etc.).

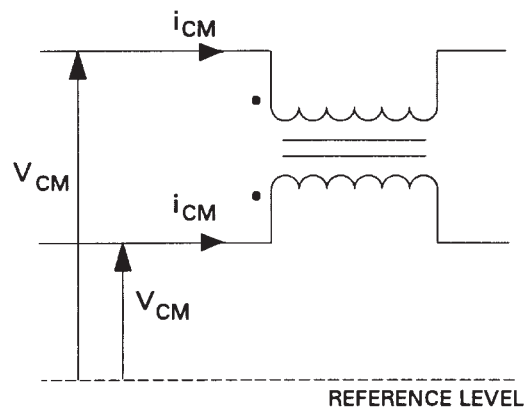

FIGURE 17 - CHOKE WITH COMMON MODE INPUTS

Figure 18 shows a differential voltage present on the input of choke. In this case the resultant current flows through the load and returns through the choke.

Both currents flow in opposite directions and produce out of phase, canceling core flux.

The effect of this is that the differential mode signal sees no resultant inductive impedance and the choke is effectively "invisible".

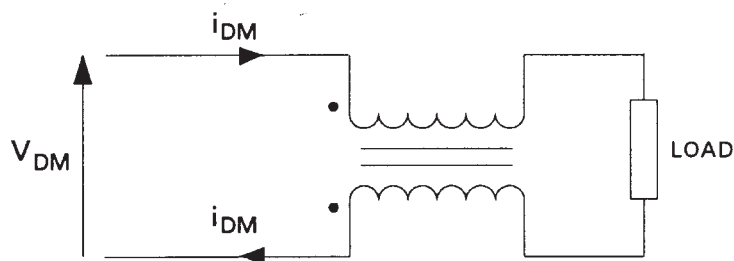

FIGURE 18 - CHOKE WITH DIFFERENTIAL MODE INPUTS

The perfect choke described above would have an infinite frequency response and present infinite impedance to common mode signals, with no impedance to differential mode signals. A real choke will have leakage inductance, and distributed capacitance as well as winding resistance and core losses, exactly as in a transformer. These effects produce a limited frequency response and a finite common mode impedance, as well as a small but non-zero differential mode impedance.

As a general guide the operating frequency of a common mode choke is inversely proportional to its common mode inductance.

5.0 TRANSFORMER TESTS

Measurement of the transformer equivalent circuit parameters shown in Figure 15 is usually required to verify calculated values. Two simple tests enable the parameters to be deduced.

5.1 OPEN CIRCUIT TEST

This test is usually performed at a frequency low enough for the transformer capacitance terms to be ignored. The test circuit is shown in Figure 19.

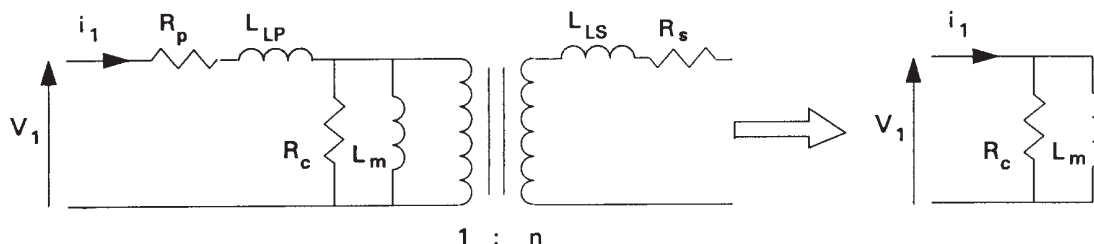

FIGURE 19 - OPEN CIRCUIT TEST

The transformer rated voltage V_1 is applied to the primary coil terminals. The secondary is left Open Circuit so no current flows and the secondary leakage inductance and winding resistance can be ignored. Usually Primary leakage inductance and resistance are negligibly small compared to magnetizing inductance and core loss so the equivalent circuit reduces to that shown on the RHS of Figure 19. Measuring current amplitude and phase with respect to applied voltage will give us the magnetizing reactance and core loss resistance. Modern electronic impedance bridges can do all the calculations necessary and give a direct digital read-out of measured inductance and resistance.

Because the magnetizing inductance is measured in this test, it has acquired the more commonly used title of OPEN CIRCUIT INDUCTANCE (L_o or OCL) and this terminology will be used throughout the rest of this document.

5.2 SHORT CIRCUIT TEST

Again inter-winding capacitance can be ignored, and the test circuit is shown in Figure 20.

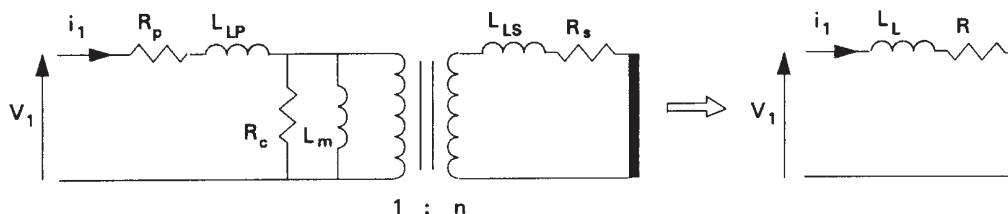

FIGURE 20 - SHORT CIRCUIT TEST

The secondary coil is short circuited and rated current applied to the primary terminals. The OCL and core resistance are now in parallel with much smaller impedances (almost a short circuit) so can be ignored in the equivalent circuit. The resultant equivalent circuit for the short circuit test is shown on the RHS of Figure 20. The measured leakage inductance and winding resistance will be the values referred over to the primary winding (see section 2.13). Measurement of magnitude and phase of the primary voltage and current give us the inductance and resistance values.

Measurement of the winding resistances is also possible directly using a DC voltage applied to primary and then secondary windings. The resistances measured are then called the Direct Current Resistances (DCR) of the individual windings.

6.0 FREQUENCY RESPONSE CHARACTERISTICS

The following section uses the equivalent circuit developed in section 3.0, together with relevant simplifying assumptions to explain the frequency response curve of a general wide band signal transformer. Inter winding capacitance will be assumed to have negligible effect at the frequencies of interest.

When the transformer is connected to a source and load (both assumed to be purely resistive) , we can draw the following equivalent circuit, which is a further simplification of that shown in Figure 15, where the load resistance, secondary leakage inductance and secondary winding resistance have all been referred to the primary side of the ideal transformer element.

Note that once all elements including the load have been moved to the primary side of the ideal transformer, the ideal transformer element can be discarded from the equivalent circuit since no current flows in its secondary winding, and therefore none in its primary!

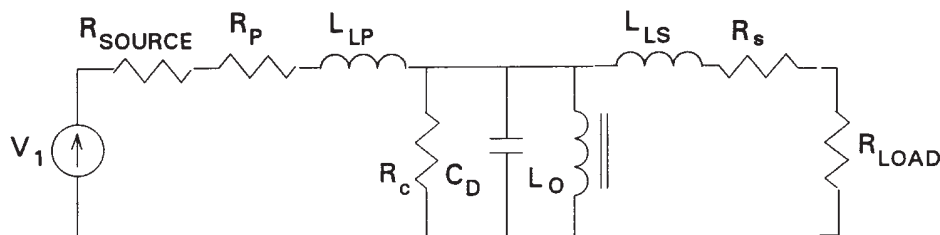

FIGURE 21 - EQUIVALENT CIRCUIT WITH SOURCE AND LOAD

6.1 LOW FREQUENCY RESPONSE

At low frequency further simplifications are possible ...

- (1) Impedance of C_D is high enough to be neglected.
- (2) R_{SOURCE} and R_P can be combined to form primary resistance R_1 . $R_P \ll R_{SOURCE}$.
- (3) R_{LOAD} , R_C and R_S can be combined to give R_2 . $R_S \ll R_{LOAD}$ and $R_C \gg R_{LOAD}$.
- (4) Leakage reactances are small enough to be neglected.

We can now draw the Low Frequency equivalent circuit as in Figure 22. V_2 will be a good approximation to the voltage across the load if assumptions (1) to (4) are valid.

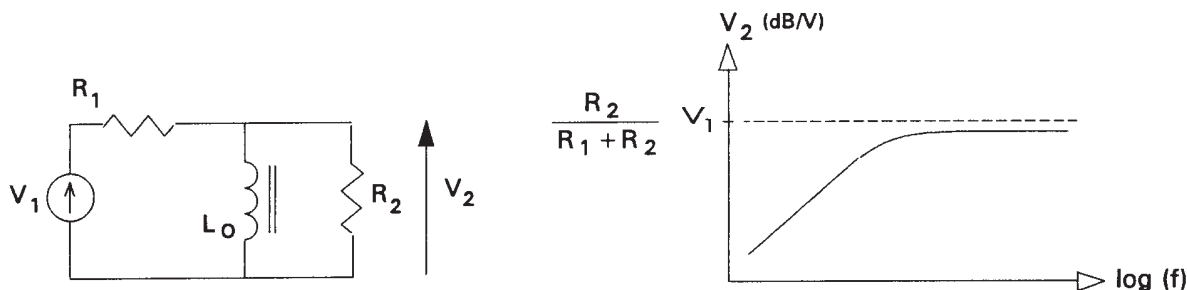

FIGURE 22 - LF EQUIVALENT CIRCUIT

FIGURE 23 - LF RESPONSE

The impedance of L_O (Open Circuit Inductance) is proportional to f . As f decreases then the impedance of the parallel combination of R_2 and L_O also decreases. .

As $f \Rightarrow 0$ then $V_2 \Rightarrow 0$ as shown in Figure 23.

Low frequency response is mainly a function of Open Circuit Inductance (OCL). As OCL increases, then LF response improves.

6.2 HIGH FREQUENCY RESPONSE

At high frequencies the following simplifications from Figure 21 are possible ...

- (1) Impedance of OCL (L_O) is large enough to be neglected.
- (2) R_{SOURCE} and R_P can be combined to form primary resistance R_1 . $R_P \ll R_{SOURCE}$.
- (3) R_{LOAD} , R_C and R_S can be combined to give R_2 . $R_S \ll R_{LOAD}$ and $R_C \gg R_{LOAD}$.
- (4) Leakage Inductances can be lumped together.

We can now draw the High Frequency equivalent circuit as in Figure 24. V_2 will be a good approximation to the voltage across the load if assumptions (1) to (4) are valid.

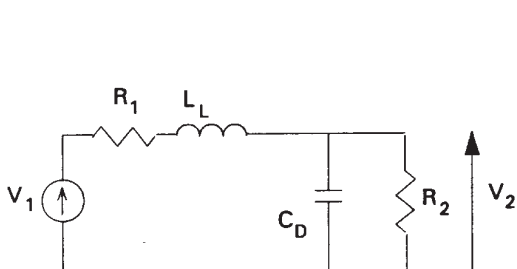

FIGURE 24 - HF EQUIVALENT CIRCUIT

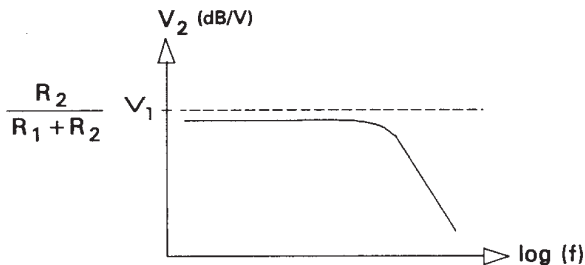

FIGURE 25 - HF RESPONSE

The impedance of LL is proportional to f , and the impedance of CD is inversely proportional to f . Both of these effects mean that ...

As $f \Rightarrow \infty$ then $V_2 \Rightarrow 0$ as shown in Figure 25.

High frequency response is mainly a function of leakage inductance and distributed capacitance. The lower the value of these parameters the better the HF response.

6.3 OPERATING FREQUENCY RESPONSE

In the perfect case, at frequencies within the operating frequency range of the transformer the transformer behaves as an ideal element ...

$$V_2 = \frac{R_{LOAD}}{R_{SOURCE} + R_{LOAD}} \cdot V_1 \quad \text{or if } R_{SOURCE} \ll R_{LOAD} \quad \text{then } V_2 = V_1$$

In reality the equivalent circuit parameters will have the effect of reducing the output voltage by a small factor. It is usual to express this attenuation as INSERTION LOSS (dB) where

$$\text{Insertion Loss (dB)} = 10 \log_{10} \frac{V_2}{V_1}$$

Combining sections 6.1 to 6.3 we have Figure 26 below.

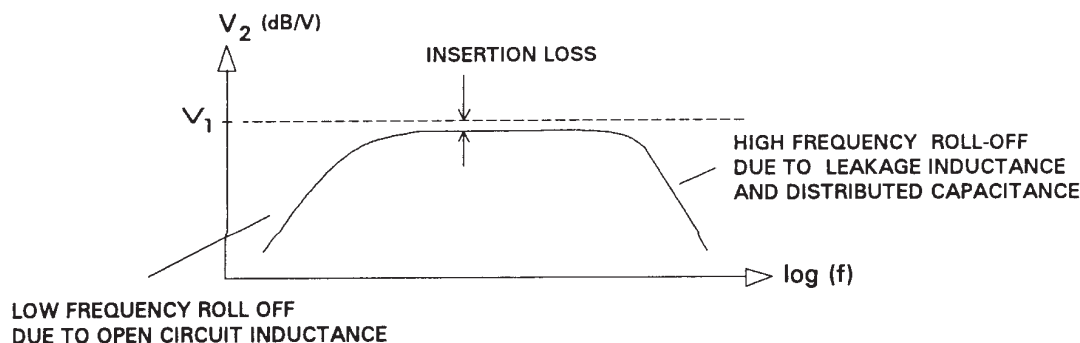

FIGURE 26 - TRANSFORMER FREQUENCY RESPONSE

7.0 TIME DOMAIN RESPONSE CHARACTERISTICS

The purpose of this section is to give a simple explanation of the time domain response characteristics of a simple pulse transformer. Much of the mathematics involved in giving a complete analysis involves the solution of differential equations (usually second order inhomogeneous) and is rather complicated. To show the full derivation of the results quoted lies outside the scope of this document. In the following section we shall make the following assumptions in order to simplify the analysis ...

- (1) Winding resistances are negligible compared to source and load resistances.
- (2) Leakage inductances can be lumped together into one term.
- (3) Core loss current is negligible compared to load current.
- (4) Inter winding capacitance effects can be neglected.

These assumptions are realistic for the majority of real situations and using them does not affect the fundamental nature of the results obtained. The equivalent circuit of Figure 20 is thus modified to that shown in Figure 27 below.

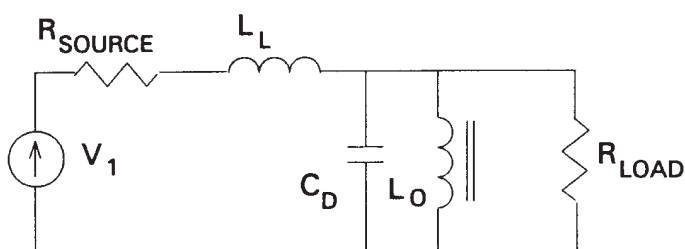

FIGURE 27 - TIME DOMAIN RESPONSE EQUIVALENT CIRCUIT

7.1 PULSE RISING EDGE RESPONSE

The equivalent circuit is shown in Figure 28. OCL can be omitted as it presents effectively infinite impedance to the instantaneously changing input voltage. We will assume source impedance R_1 is negligible.

If we sum the currents at node X and then differentiate through the equation with respect to time we obtain the second order inhomogeneous differential equation ...

$$\frac{d^2V_2}{dt^2} + \frac{1}{R_2C_D} \cdot \frac{dV_2}{dt} + \frac{1}{L_L C_D} \cdot V_2 = \frac{V_1}{L_L C_D}$$

The solution to this equation is of the form ...

[equation 18]
$$V_2 = V_1(1 + Ae^{-\alpha t} + Be^{-\beta t})$$

The waveforms resulting from this equation are shown in Figure 29. The exact extent of the overshoot, and the waveform rise time depend on the relative values of R_2 , L_L and C_D .

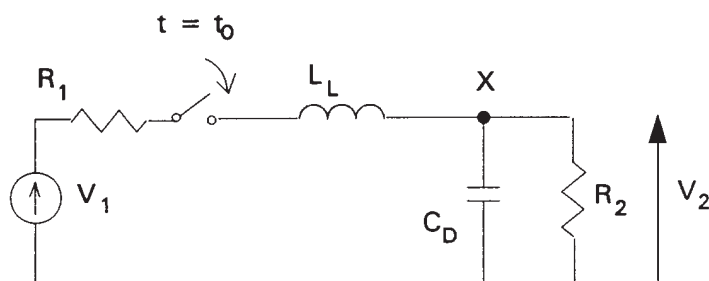

FIGURE 28 - RISING EDGE EQUIVALENT CIRCUIT

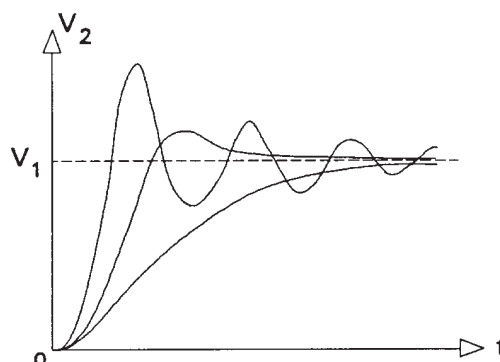

FIGURE 29 - RISING EDGE WAVEFORMS

7.2 PULSE PEAK RESPONSE

Once the rising edge transient has died away we enter the second stage of the applied ideal pulse, the pulse peak. The equivalent circuit is shown in Figure 30. Leakage inductance can be neglected as it will be much smaller than the OCL. The distributed capacitance can also be neglected as the rate of change of voltage across it during the pulse peak is small, so the current through it will be small compared to the Load current.

Again summing currents and then differentiating through the equation with respect to time, we obtain the first order differential equation ...

$$\frac{R_1 + R_2}{R_1 R_2} \cdot \frac{dV_2}{dt} + \frac{V_2}{L_O} = 0$$

Initial conditions are such that at $t = 0$:

$$V_2 = \frac{R_2}{R_1 + R_2} \cdot V_1 = kV_1$$

The solution to this equation has the form ...

[equation 19]
$$V_2 = V_1 k e^{\frac{-kR_1}{L_O} t}$$

i.e. the load voltage decays exponentially away from its initial value as shown in Figure 31. The rate of decay is inversely proportional to L_O so that the higher the value of OCL, then the smaller the load voltage deviation during the pulse.

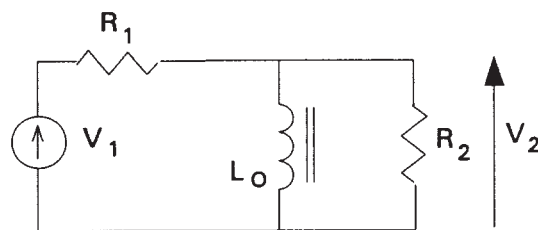

FIGURE 30 - PULSE PEAK EQUIVALENT CIRCUIT

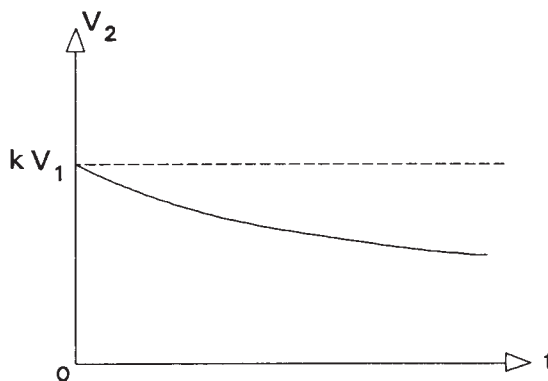

FIGURE 31 - PULSE PEAK RESPONSE

7.3 PULSE FALLING EDGE RESPONSE

The equivalent circuit is shown in Figure 32. Leakage inductance can be ignored as it is usually small compared to the OCL.

Summing node currents as before and differentiating through with respect to time we obtain the second order homogeneous differential equation ...

$$\frac{d^2 V_2}{dt^2} + \frac{1}{C_D R_2} \cdot \frac{dV_2}{dt} + \frac{V_2}{L_O} = 0$$

The solution to this equation has the form ...

[equation 20]
$$V_2 = V_1 (Ae^{\alpha t} + Be^{\beta t})$$

The exact shape of the waveform depends on the relative values of OCL and C_D

If the core magnetizing current is negligible the waveform decays roughly as an exponentially damped sinusoid.

If magnetizing current is too large to be neglected a much larger undershoot occurs as the decaying magnetic field in the core causes a "back emf" to be generated.

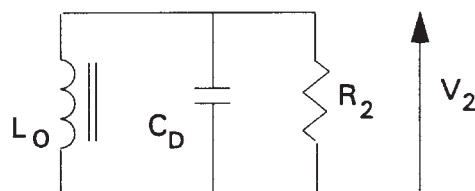

FIGURE 32 - FALLING EDGE EQUIVALENT CIRCUIT

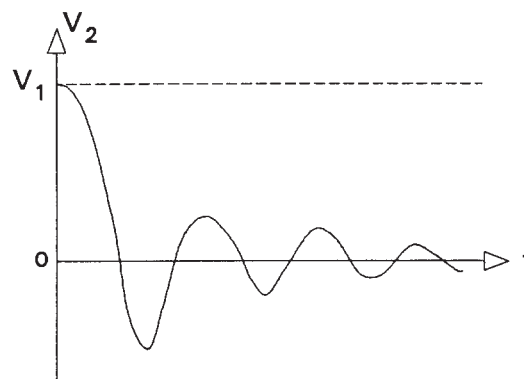

FIGURE 33 - FALLING EDGE RESPONSE

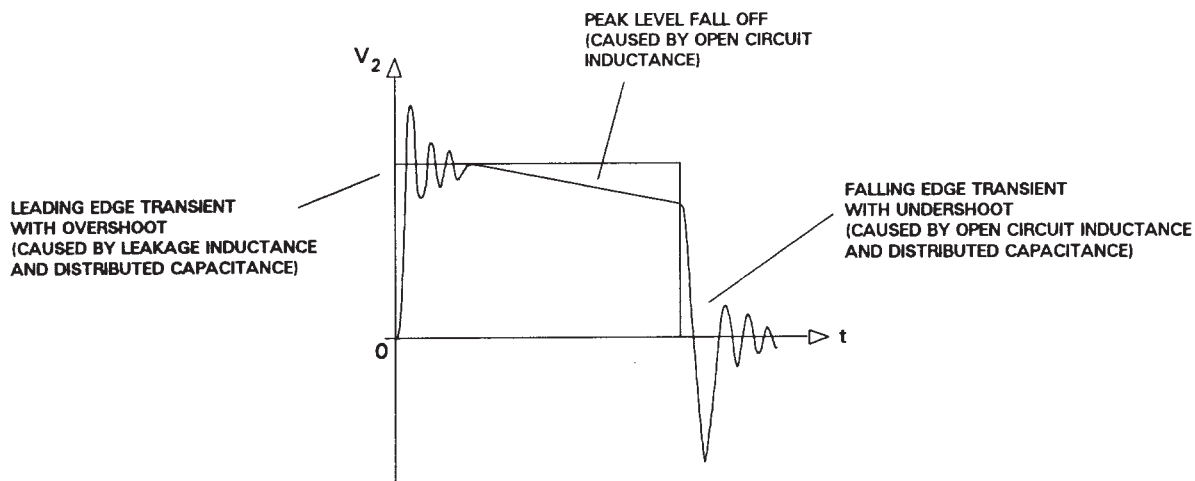

FIGURE 34 - TRANSFORMER PULSE RESPONSE

Figure 34 shows the combined results of sections 7.1 to 7.3 and gives the complete pulse response. The transients and peak fall off have been exaggerated for clarity, and in a well designed transformer will be much less noticeable.

APPENDIX 1

GLOSSARY OF MAGNETIC TERMS

TERM or PARAMETER	DESCRIPTION
Air Gap	A small gap in an otherwise solid transformer core that is used to prevent DC current saturating the core.
Amp (A)	The S. I. unit of Electric Current.
Ampère's Law	Relates Magnetic Field to Current in an electromagnetic circuit.
C_D	DISTRIBUTED CAPACITANCE (unit : F). The equivalent circuit parameter used to model stray or parasitic capacitances present in a coil due to the coil interacting with itself and its surroundings. It is a capacitance in parallel with the ideal transformer primary winding.
C_{ww}	INTER-WINDING CAPACITANCE (unit : F). The equivalent circuit parameter used to model the effective capacitance between transformer primary and secondary coils.
Coercive Force (H_c)	That value of Magnetic Field (H) which must be applied to a hysteretic magnetic material such that the magnetic flux density (B) within the material is zero.
Common Mode Choke	A type of transformer used so that it presents a finite impedance to common-mode signals, but zero impedance to differential mode signals.
Core Loss	General term expressing the power losses in a core due to Eddy current and Hysteresis Losses.
Coupling Coefficient (k)	A term that is used to express the degree to which the magnetic flux of two coils is inter-linked ($0 < k < 1$). For perfect coupling $k = 1$
DCR	DIRECT CURRENT RESISTANCE (unit : Ω). The DC resistance of the wire used to wind a transformer's coils. It is a resistance in series with the ideal transformer winding.
Dielectric Withstand Voltage	That breakdown voltage which a transformer can withstand between its primary and secondary windings.
Eddy Current	Current that flows within a transformer core as a result of the core magnetic field and causes losses.
Equivalent Circuit	A circuit model that represents a non-ideal device (transformer) using several ideal components. Using such a representation enables device behaviour to be modelled and predicted.
ET	The voltage-time product that a transformer can tolerate before the coil enters saturation and can no longer support a magnetic field. (unit : Vs)
Faraday's Law	Relates Magnetic Flux to induced (or applied) voltage in an electro-magnetic circuit.
Ferrite	A type of magnetic material made from sintered non-metallic oxides.
Flux (ϕ)	An abstract concept describing the presence of a magnetic field or magnetic energy (unit : Wb)
Flux Density (B)	The amount of Flux per unit area (unit : Wb/m^2)
Henry (H)	The S.I. unit of Inductance.
HI POT	See "Dielectric Withstand Voltage (DWV)". So called after the name of the machine that measures DWV.
Hysteresis	A material exhibits hysteresis if, when passing between two states, the material does not follow a reversible path. Hysteresis is associated with energy loss.

Ideal Transformer	A transformer with no losses or stray inductive and capacitive elements.
Insertion Loss	The extent to which a signal is attenuated when passing from primary to secondary winding of the transformer.
L_L	LEAKAGE INDUCTANCE (unit : H). The self inductance of a coil due to the flux it generates being not completely linked to other windings. It is an inductance in series with the ideal transformer winding.
Magnetizing Current (I_m)	The current flowing in a transformer primary winding that is required to support the core magnetic field.
Magnetizing Force	The Ampere-Turns applied to a magnetic circuit.
Mutual Inductance (M)	The inductance that exists between two (or more) coils due to the interaction of their generated flux with each other (unit : H)
OCL	OPEN CIRCUIT INDUCTANCE (unit : H). The equivalent circuit parameter that is measured during a transformer Open Circuit Test. It is a parallel inductance across the ideal transformer primary winding.
Open Circuit Test	A transformer test measuring OCL and core losses. A voltage is applied to the transformer primary and power measured while the secondary coil is left open circuit.
Overshoot	Voltage deviation above an ideal desired upper limit. Associated with circuit transient behaviour.
Parallel Impedance (Z)	The impedance measured on each winding of a common-mode choke. The impedance is a function of frequency.
Permeability (μ)	That property of a material defining how much Magnetic Flux Density results from a given applied Magnetizing Force. $B = \mu H$.
Permeability of Free Space (μ₀)	In free space μ is constant , and has a value $4\pi \times 10^{-7}$ H/m
Primary Inductance	See "Open Circuit Inductance (OCL)"
Relative Permeability (μ_R)	$\mu_R = \mu / \mu_0$
Reluctance (ℳ)	That property of a material that defines the extent to which the material "resists" the application of a magnetic field. It is inversely proportional to Permeability.
RISE TIME	The secondary waveform rise time that results from the application of an ideal step voltage (zero rise time) to the primary winding.
Saturation	The point at which flux density (B) no longer increases with applied Magnetic Field (H).
Self Inductance (L)	The inductance of a coil due to the interaction of its generated flux with itself (unit : H)
Short Circuit Test	A transformer test measuring Leakage inductance. A current is applied to the transformer primary and power measured while the secondary coil is short-circuited.
Transformer	A device that transfers electrical energy via intermediate magnetic energy.
Turns Ratio (n)	The number of turns on a transformers secondary coil divided by the number of turns on its primary. Usually expressed as 1:n
Undershoot	Voltage deviation below an ideal desired lower limit. Associated with circuit transient behaviour.
Weber (Wb)	The S.I. unit of Magnetic Flux.
Winding Resistance	See "DCR"

APPENDIX 2

MAGNETIC MATERIALS

- SILICON-IRON ALLOYS** ⇒ High Rel. Permeability - Non orientated $\mu_R \approx 10,000$ (max)
 - Grain oriented $\mu_R \approx 50,000$ (max)
 Tough, durable material
 Available in variety of core types, usually used in laminated cores.
 Main applications power and audio transformers
 Usable frequency range 50Hz - 10kHz
 Low resistivity
- NICKEL-IRON ALLOYS** ⇒ Most useful alloys use between 50/50 and 80/20 Ni/Fe mixtures
 High Permeability - $\mu_R \approx 50,000$ to 200,000 depending on composition and treatment
 Main applications wide-band audio transformers
 Usable frequency range 100Hz - 50kHz
 Low resistivity
- COBALT-IRON ALLOYS** ⇒ Most commonly known as "Supermendur" (Trade Name)
 High Permeability - $\mu_R \approx 50,000$
 Main applications power transformers and inverter transformers
 Usable frequency range 50Hz - 5kHz
 Low resistivity
- POWDERED CORES** ⇒ Made from powdered and sintered magnetic materials such as Molybdenum Permalloy and Iron Powder
 High resistivity
 Nearly constant but Low permeability
 $\mu_R \approx 500$ (max)
 Available in variety of core shapes.
 Molybdenum useful in filter inductors and coils 10Hz - 100kHz
 Iron powder useful in coils 2kHz - 300MHz
- AMORPHOUS ALLOYS** ⇒ A relatively new class of material produced by ultra-rapid cooling of the material from above its crystalline temperature. Cooling takes place so rapidly that the material cannot crystallize before solidification and an amorphous structure results.
 Very brittle
 Only available as tape, so useful only for wound cores.
 Useful frequency range 50Hz - 1MHz
- FERRITES** ⇒ Non-metallic ferromagnetic oxides.
 Very high resistivities and low core losses
 Low permeability $\mu_R \approx 8,000$ (max)
 Manufactured by sintering powdered material with a non-conducting filler material for stability.
 Two main types - Manganese-Zinc $\mu_R \approx 7,000$
 - Nickel-Zinc $\mu_R \approx 3,000$
 Main uses in high frequency signal transformers
 Available in wide range of core types including toroids
 Useful frequency range 20kHz - 100MHz