

**NVE**   
NVE CORPORATION  GMR Sensor Catalog  

**NVE GMR Sensor Applications**

- Position of Pneumatic Cylinders
- Position in Robotics Applications
- Speed and Position of Bearings
- Speed and Position of Electric Motor Shafts
- General Field Detection in Implantable Medical Devices
- Wheel Speed Sensing for ABS Brake Applications
- Transmission Gear Speed Sensing for Shift Control
- Low Field Detection in Currency Applications
- Current Sensing in PCB Traces and Wires
- Overcurrent and Short Circuit Detection
- Vehicle Detection for Traffic Counting Applications

**Table of Contents**

Introduction to NVE GMR Sensors ..... 4  
 GMR Materials Overview ..... 5  
 Basic Sensor Design ..... 7  
 Signal Processing ..... 11  
 AA and AB-Series Analog Sensors ..... 12  
 AA Sensors ..... 14  
 AAH Sensors ..... 16  
 AAL Sensors ..... 18  
 AAV Sensors ..... 20  
 AB Sensors ..... 24  
 ABH Sensors ..... 26  
 GMR Switch Precision Digital Sensors ..... 28  
 GMR Switch Product Selection Guide ..... 30  
 AD0xx-xx to AD7xx-xx ..... 36  
 AD8xx-xx to AD9xx-xx ..... 40  
 ADH0xx-xx ..... 44  
 GT Sensors™ ..... 46  
 ABL Sensors ..... 47  
 AKL Sensors ..... 52  
 Circuit Board Sensor Products ..... 56  
 AG21x-07 Cylinder Position Sensors ..... 56

AG-Series Currency Detection Sensors .....	59
Peripheral Integrated Circuits .....	61
DB001-00 Series Power Switch IC.....	62
DB002-02 Series Power Switch IC.....	65
DC-Series Voltage Regulators.....	68
DD-Series Signal Processing ICs.....	70
Evaluation Kits .....	73
AG001-01 Analog Sensor Evaluation Kit .....	74
AG003-01 Current Sensor Evaluation Kit.....	75
AG910-07 and AG911-07 GMR Switch Evaluation Kits.....	76
AG920-07 GT Sensor Evaluation Kit.....	77
Application Notes for GMR Sensors .....	78
General Comments .....	79
Competitive Technologies .....	79
GMR Material Physics .....	80
GMR Materials Types Manufactured by NVE.....	84
Temperature Characteristics of GMR Sensors.....	85
Hysteresis in GMR Sensors .....	89
GMR Magnetic Field Sensors (Magnetometers) .....	94
GMR Magnetic Gradient Sensors (Gradiometers).....	96
Magnetic Reference Information .....	98
Signal Conditioning Circuits .....	99
Noise In NVE Giant Magnetoresistive Sensors.....	105
Use Of GMR Magnetic Field Sensors .....	106
Application Notes for GT Sensors.....	109
Measuring Displacement .....	116
Current Measurement .....	117
Magnetic Media Detection.....	126
Currency Detection and Validation .....	127
Appendix .....	131
Package Drawings and Specifications .....	131
Recommended Solder Reflow Profile .....	134
Magnet Data .....	135
Part Numbers and Marking Codes.....	137
Definitions and Conversion Factors.....	140
NVE Company Profile.....	143

## Introduction to NVE GMR Sensors

In 1988, scientists discovered the “Giant Magneto Resistive” effect—a large change in electrical resistance that occurs when thin, stacked layers of ferromagnetic and non-magnetic materials are exposed to a magnetic field. Since then, many companies have sought to develop practical applications for this intriguing technology. NVE Corporation has taken the lead by developing the first commercially available products making use of GMR technology, a line of magnetic field sensors that outperform traditional Hall Effect and AMR magnetic sensors.

NVE introduced its first analog sensor product in 1995. Since then, our product line has grown to include several variations on analog sensors, the GMR Switch™ line of precision digital sensors, and our newest products, the GT Sensors™ for gear tooth and encoder applications. In addition to these products, NVE offers printed circuit board assemblies for pneumatic cylinder position and currency detection applications as well as peripheral integrated circuits designed to work with our GMR sensors in a variety of applications. Finally, NVE remains committed to custom product developments for large and small customers in order to develop the best possible sensor for the customer’s application.

NVE magnetic sensors have significant advantages over Hall Effect and AMR sensors as shown in the following chart. In virtually every application, NVE sensors outperform the competition—often at a significantly lower installed cost.

Benefits:	GMR	HALL	AMR
Physical Size	Small	Small	Large
Signal Level	Large	Small	Medium
Sensitivity	High	Low	High
Temperature Stability	High	Low	Medium
Power Consumption	Low	Low	High
Cost	Low	Low	High

## GMR Materials Overview

The heart of NVE's sensor products are the proprietary GMR materials produced in our factory. These materials are manufactured in our on-site clean room facility and are based on nickel, iron, cobalt, and copper. Various alloys of these materials are deposited in layers as thin as 15 Angstroms (five atomic layers!), and as thick as 18 microns, in order to manufacture the GMR sensor elements used in NVE's products.

The following diagrams show how the GMR effect works in an NVE sensor using multilayer GMR material. Note that the material is sensitive in the plane of the IC, rather than orthogonally to the IC, as is the case with Hall elements.

### No External Magnetic Field

High Resistance

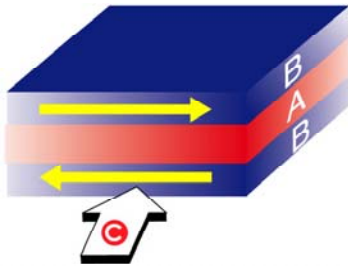

**A** Is a conductive, nonmagnetic interlayer. Magnetic moments in alloy **B** layers face opposite directions due to the anti-ferromagnetic coupling. Resistance to current **C** is high.

### External Magnetic Field

Low Resistance

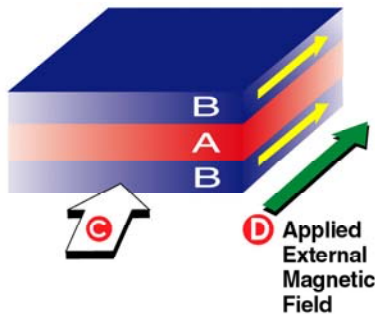

Applying external magnetic field **D** over comes anti-ferromagnetic coupling, aligning magnetic moments in alloy **B** layers. Electrical resistance drops dramatically; 10% to 15% is typical.

NVE's GMR materials are noteworthy in comparison with other GMR material types in that NVE's material cannot be damaged with the application of extremely large magnetic fields. GMR materials from other sources often rely on keeping one of the magnetic layers internally magnetized, or pinned, in a specific direction, and allowing the other layer to rotate and thus provide the GMR effect. In some of these materials, an external magnetic field as small as 200 Gauss can upset this pinned layer, thus permanently damaging the sensor element. Most of NVE's GMR materials rely on anti-ferromagnetic coupling between the layers; as a result they are not affected by extremely large fields, and will resume normal operation after the large field is removed. NVE has recently introduced a production GMR material with a pinned magnetic layer, this pinned layer uses a synthetic anti-ferromagnet for the pinning, which cannot be upset at temperatures below 300°C. As a result, NVE's pinned GMR material is not susceptible to upset problems.

The following chart shows a typical characteristic for NVE's standard multilayer GMR material:

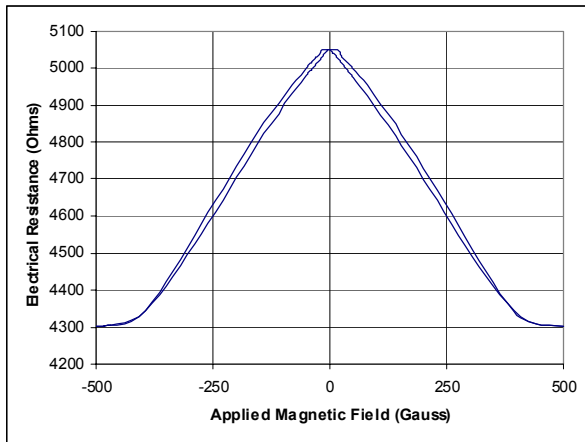

Notice that the output characteristic is omnipolar, meaning that the material provides the same change in resistance for a directionally positive magnetic field as it does for a directionally negative field. This characteristic has advantages in certain applications.

For example, when used on a magnetic encoder wheel, a GMR sensor using this material will provide a complete sine wave output for each pole on the encoder (rather than each pole pair, as with a Hall Effect sensor), thus doubling the resolution of the output signal.

The material shown in the plot is used in most of NVE's GMR sensor products. It provides a 98% linear output from 10% to 70% of full scale, a large GMR effect (13% to 16%), a stable temperature coefficient (0.14%/°C) and temperature tolerance (+150°C), and a large magnetic field range (0 to ±300 Gauss).

In addition to manufacturing this excellent GMR material, NVE is constantly developing new GMR materials. New products have recently been introduced which use three new materials: one with double the magnetic sensitivity of the standard material, one with half the magnetic hysteresis, and one with a synthetic antiferromagnet pinned layer designed for use in magnetic saturation. Some of these new materials are suitable for operation to +225°C. Please see the application notes section of this catalog for a complete description of the GMR material types available in NVE's magnetic sensors.

NVE continues to lead the market in GMR-based magnetic sensors due to constant emphasis on developing new or improved GMR materials and frequent new product releases utilizing these improvements.

## Basic Sensor Design

NVE manufactures three basic sensor element types: magnetometers, which detect the strength of the applied magnetic field, gradiometers (or differential sensors), which detect the difference in the applied magnetic field strength at two discrete points on the sensor element, and spin valve sensors, which change in output with the angular difference between the pinned layer and the free layer of the GMR material while the device is exposed to a saturating magnetic field.

These three basic sensor element types are described in the sections below.

### Magnetometers

NVE's magnetometers are covered by our basic GMR material and sensor structure patents and have unique features designed to take advantage of the characteristics of GMR sensor materials. A photomicrograph of an NVE sensor element is shown below:

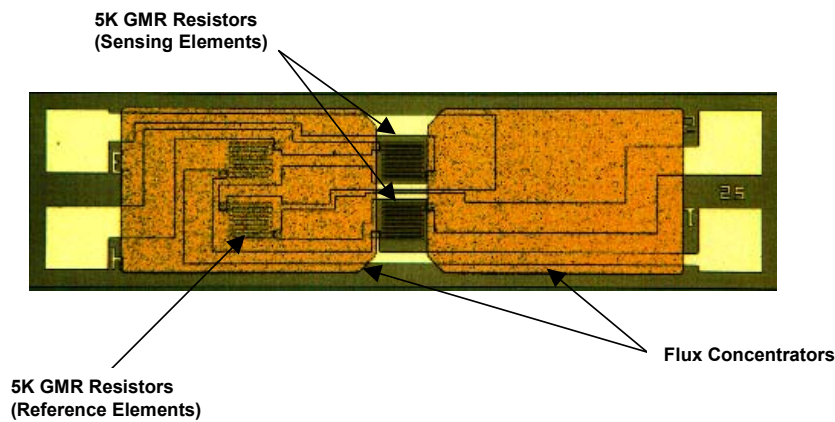

The size of this IC is approximately 350 microns by 1400 microns. The sensor is configured as a Wheatstone bridge. The serpentine structures in the center of the die and to the left of center under the large plated structure are 5 k $\Omega$  resistors made of GMR material.

The two large plated structures shown on the die are flux concentrators. They serve two purposes. First, notice that they cover two of the resistors in the Wheatstone bridge. In this configuration the flux concentrators function as a shield for these two resistors, preventing an applied magnetic field from reaching them. Therefore, when a field is applied, the two GMR resistors in the center of the die decrease in resistance, while the two GMR resistors under the flux concentrator do not. This imbalance leads to the bridge output.

The second purpose of the flux concentrators is to vary the sensitivity of the sensor element from product to product. They work by forming a low reluctance path to the sensor elements placed between them. NVE uses a “rule of thumb” formula to calculate the effect of the flux concentrators:

$$\text{Field at sensor elements} \cong (\text{Applied Field})(60\%)(\text{FC length} / \text{gap between FCs})$$

For the sensor shown in the previous photo, the length of each flux concentrator is 400 microns, and the gap between the flux concentrators is 100 microns. Therefore, if the sensor is exposed to an applied field of 10 Gauss, the actual field at the sensor element will be about (10 Gauss)(0.6)(400 microns / 100 microns), or 24 Gauss.

NVE uses this technique to provide GMR sensors with varying sensitivity to the applied magnetic field. The following chart shows sensitivity ranges for some of NVE’s products. Sensitivity to the magnetic field is indicated by the slope of each line:

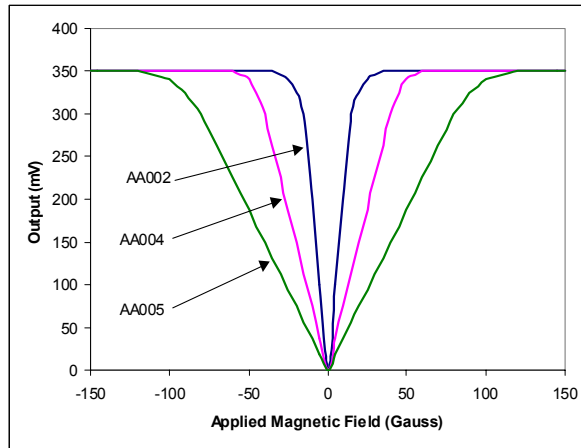

Maximum signal output from such a sensor element is typically 350 mV at 100 Gauss with a 5V power supply. This compares to an output of 5 mV under the same conditions for a Hall sensor element, and 100 mV for an AMR sensor.

## Gradiometers

NVE's gradiometers, or differential sensors, rely on the field gradient across the IC to generate an output. In fact, if one of these sensors is placed in a uniform magnetic field, its output voltage will be zero. This is because all four of the bridge resistors are exposed to the same magnetic field, so they all change resistance together. There is no shielding or flux concentration on a gradiometer. A simple representation of a gradiometer is shown in the diagram below:



Because all four bridge resistors contribute to the sensor's output, at maximum differential field NVE's gradiometers can provide double the output signal of our magnetometer parts—approximately 700 mV with a 5V supply. In practice, the gradient fields are typically not high enough to give this maximum signal, but signal levels of 50 mV to 200 mV are common.

NVE's GMR differential sensors are typically designed with two of the bridge resistors at one end of the IC, and two at the other end. The spacing between the two sets of resistors, combined with the magnetic field gradient on the IC, will determine the output signal from the sensor element. NVE offers three standard spacings for differential sensors: 0.3 mm, 0.5 mm, and 1.0 mm. If a different spacing is desired, contact NVE for development cost and schedule for a custom product.

The most popular application for differential sensors is in gear tooth or magnetic encoder detection. As these structures move or spin the magnetic field near their surface is constantly varying, generating a field gradient. A differential sensor, properly placed, can detect this movement by sensing the changing field gradient and provide an output for each gear tooth or each magnetic pole (see the GT Sensor section of this catalog for a more detailed explanation). Applications for these devices include detecting the speed and position of electric motor shafts or bearings, automotive transmission gear speeds, axle shaft speed in Anti-lock Braking Systems (ABS), or linear gear-tooth position.

## Spin Valve Sensors

NVE's spin valve sensors are designed using our synthetic anti-ferromagnet pinned layer. This pinned layer is very robust, and not subject to upset or reset. The basic GMR material construction includes the pinned layer and a free layer; the free layer can be influenced by an external magnetic field in the range of 30 to 200 Gauss. The output of the sensor varies in a cosine relationship to the angle between the free layer and the pinned layer.

As long as the external field strength is in the 30 to 200 Gauss range, the free layer in the GMR material is saturated. It will therefore point in the same direction as the external field, while the pinned layer remains pointed in its fixed direction. The diagram below shows a vector concept of the device operation:

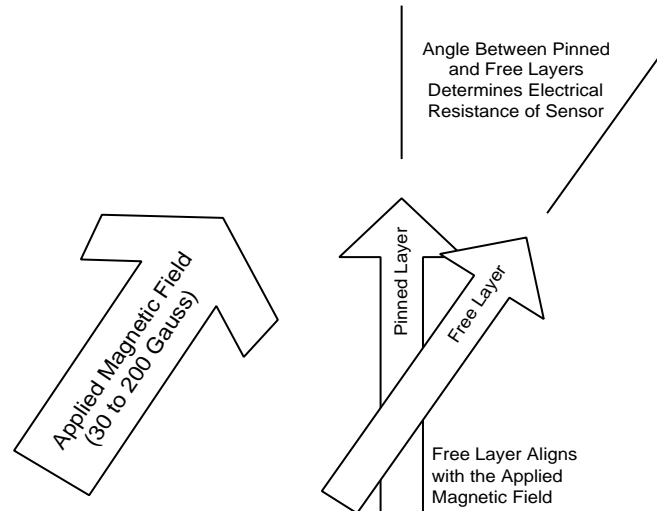

The percent change of resistance available with this GMR material is about 5%. The output is a cosine function over 360 degrees of angular movement by the external, saturating magnetic field.

## Signal Processing

Adding signal processing electronics to the basic sensor element increases the functionality of NVE's sensors. The large output signal of the GMR sensor element means less circuitry, smaller signal errors, less drift, and better temperature stability compared to sensors where more amplification is required to create a usable output.

For the GMR Switch products, NVE adds a simple comparator and output transistor circuit to create the world's most precise digital magnetic sensor. For these products, no amplification of the sensor's output signal is necessary. A block diagram of this circuitry is shown in the figure below:

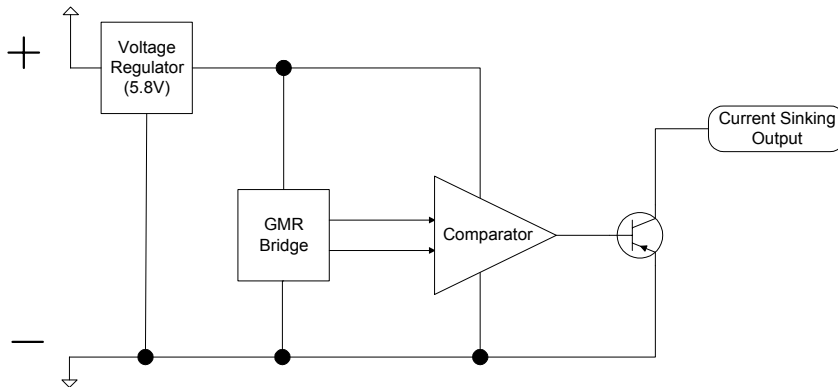

The GMR Switch holds its precise magnetic operate point over extreme variations in temperature and power supply voltage. This low cost product has revolutionized the industrial control position sensing market.

Taking this approach one step further, NVE's integrated GT Sensor products add low-gain amplification and magnet compensation circuitry to the basic sensor element to create a powerful gear tooth and encoder sensor at an affordable price.

NVE also offers certain peripheral IC products to help customers integrate GMR sensor elements into their systems and meet rigorous regulatory agency requirements for safety and survivability. These products include power switch ICs for switching large currents in industrial applications and voltage regulator ICs for reducing wide ranging automotive and industrial voltage supplies to manageable IC-friendly levels. Both of these product types retain a "bulletproof" appearance to the outside electrical world and resist damage from high voltage transients, reverse battery connections, and ESD/EMC events.

For applications where a unique product is required, NVE's in-house IC design group regularly does custom designs for our customers. These designs range from simple variations on NVE's existing parts to full custom chips for one-of-a-kind applications. For applications where a unique electronic functionality is required, please contact NVE.

## AA and AB-Series Analog Sensors

NVE’s AA and AB-Series analog GMR sensors offer unique and unparalleled magnetic sensing capabilities. These sensors are characterized by high sensitivity to applied magnetic fields, excellent temperature stability, low power consumption, and small size. These characteristics make them suitable for use in a wide variety of applications from rugged industrial and automotive position, speed, and current sensors, to low-voltage, battery-powered sensors for use in hand-held instrumentation and implantable medical devices. The unmatched versatility of these basic magnetic sensors makes them an excellent choice for a wide range of analog sensing applications.

The AA-Series sensors use NVE’s patented GMR materials and on-chip flux concentrators to provide a directionally sensitive output signal. These sensors are sensitive in one direction in the plane of the IC, with a cosine-scaled falloff in sensitivity as the sensor is rotated away from the sensitive direction. Also, these devices provide the same output for magnetic fields in the positive or negative direction along the axis of sensitivity (omnipolar output). All sensors are designed in a Wheatstone bridge configuration to provide temperature compensation. Two packages are offered, an SOIC8 and an MSOP8. These sensors are also available in die form on a special-order basis.

There are three families of NVE’s basic AA-Series sensors: the standard AA-Series, the AAH-Series, and the AAL-Series. Each of these sensor families uses a different GMR material, with its own characteristics. The comparison table below summarizes the different characteristics of the GMR materials:

Parameter	AA Series	AAH Series	AAL Series
Sensitivity to Applied Fields	High	Very High	High
Field Range of Operation	High	Low	Medium
Hysteresis	Medium	High	Low
Temperature Range	High	Very High	Very High

The AB-Series sensors are differential sensor devices, or gradiometers, which take advantage of the high output characteristics of NVE’s GMR materials. Two families of AB sensors are offered, the standard AB-Series and the ABH-Series. They have operational characteristics similar to the AA and AAH sensors described in the table above but with the bipolar linear output characteristics of a differential sensor.

Within these different sensor families, customers can find an excellent match to their analog sensor requirements.

## Quick Reference: AA and AB-Series

For comparison and product selection purposes, the following table lists all available AA and AB-Series analog sensors, with some of their key characteristics:

### Magnetometers:

Part Number	Linear Range ( Oe <sup>1</sup>  )		Sensitivity (mV/V-Oe <sup>1</sup> )		Maximum Non-linearity (% Uni. <sup>2</sup> )	Maximum Hysteresis (% Uni. <sup>2</sup> )	Maximum Operating Temp (°C)	Typical Resistance (Ohms)	Package
	Min	Max	Min	Max					
AA002-02	1.5	10.5	3.0	4.2	2	4	125	5K	SOIC8
AA003-02	2.0	14	2	3.2	2	4	125	5K	SOIC8
AA004-00	5.0	35	0.9	1.3	2	4	125	5K	MSOP8
AA004-02	5.0	35	0.9	1.3	2	4	125	5K	SOIC8
AA005-02	10.0	70	0.45	0.65	2	4	125	5K	SOIC8
AA006-00	5.0	35	0.9	1.3	2	4	125	30K	MSOP8
AA006-02	5.0	35	0.9	1.3	2	4	125	30K	SOIC8
AAH002-02	0.6	3.0	11.0	18.0	6	15	150	2K	SOIC8
AAH004-00	1.5	7.5	3.2	4.8	4	15	150	2K	MSOP8
AAL002-02	1.5	10.5	3.0	4.2	2	2	150	5.5K	SOIC8

### Gradiometers:

Part Number	Linear Range ( Oe <sup>1</sup>  )		Resistor Spacing (mm)	Maximum Non-linearity (% Uni. <sup>2</sup> )	Maximum Hysteresis (% Uni. <sup>2</sup> )	Maximum Operating Temp (°C)	Typical Resistance (Ohms)	Package
	Min	Max						
AB001-02	20	200	0.5	2	4	125	2.5K	SOIC8
AB001-00	20	200	0.5	2	4	125	2.5K	MSOP8
ABH001-00	5	40	0.5	4	15	150	1.2K	MSOP8

### Notes:

1. Oersted (Oe) = 1 Gauss in air.
2. Unipolar operation means exposure to magnetic fields of one polarity, for example 0 to +30 Gauss, or -2 to -50 Gauss. Bipolar operation (for example, -5 to +10 Gauss) will increase nonlinearity and hysteresis

**AA Sensors**

**Features:**

- Excellent Sensitivity to Applied Magnetic Fields
- Wheatstone Bridge Analog Output
- Operating Temperature to 125°C Continuous
- Wide Linear Range of Operation
- Near-Zero Voltage Operation
- DC to >1MHz Frequency Response
- Small, Low-Profile Surface Mount Packages

**Applications:**

- General Motion, Speed, and Position Sensing
- Low Power, Low Voltage Applications
- Low Field Sensing for Magnetic Media Detection
- Current Sensing

**Description:**

The basic AA-Series GMR sensors are general-purpose magnetometers for use in a wide variety of applications. They exhibit excellent linearity, a large output signal with applied magnetic fields, stable and linear temperature characteristics, and a purely ratiometric output.

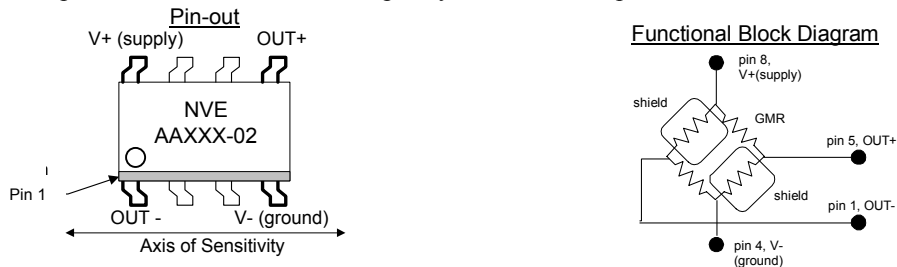

**Magnetic Characteristics:**

Part Number	Saturation Field (Oe <sup>1</sup> )	Linear Range ( Oe <sup>1</sup>  )		Sensitivity (mV/V-Oe <sup>1</sup> )		Resistance (Ohms)	Package <sup>2</sup>	Die Size <sup>3</sup> (µm)
		Min	Max	Min	Max			
AA002-02	15	1.5	10.5	3.0	4.2	5K ±20%	SOIC8	436x3370
AA003-02	20	2.0	14	2	3.2	5K ±20%	SOIC8	436x3370
AA004-00	50	5	35	0.9	1.3	5K ±20%	MSOP8	411x1458
AA004-02	50	5	35	0.9	1.3	5K ±20%	SOIC8	411x1458
AA005-02	100	10	70	0.45	0.65	5K ±20%	SOIC8	411x1458
AA006-00	50	5	35	0.9	1.3	30K ±20%	MSOP8	836x1986
AA006-02	50	5	35	0.9	1.3	30K ±20%	SOIC8	836x1986

**General Characteristics:**

Parameter	Min	Typical	Max	Unit
Input Voltage Range	<1 <sup>4</sup>		24 <sup>4</sup>	Volts
Operating Frequency	DC		>1	MHz
Operating Temperature Range	-50		125	°C
Bridge Electrical Offset	-4		+4	mV/V
Signal Output at Max. Field		60		mV/V
Nonlinearity			2	% (unipolar) <sup>5</sup>
Hysteresis			4	% (unipolar) <sup>5</sup>
TCR		+0.14		% / °C <sup>6</sup>
TCOI		+0.03		% / °C <sup>6</sup>
TCOV		-0.1		% / °C <sup>6</sup>
Off Axis Characteristic		Cos β <sup>7</sup>		
ESD Tolerance		400		V pin-to-pin HBM

**Notes:**

1. 1 Oersted (Oe) = 1 Gauss in air.
2. See the Appendix for package dimensions and tolerances.
3. Sensors can be provided in die form by special request.
4. GMR AA-Series sensors are pure ratiometric devices meaning that they will operate properly at extremely low supply voltages. The output signal will be proportional to the supply voltage. Maximum voltage range is limited by the power dissipation in the package and the maximum operating temperature of the sensor.
5. Unipolar operation means exposure to magnetic fields of one polarity, e.g., 0 to 30 Gauss, or 2 to -50 Gauss, but not -20 to +30 Gauss (bipolar operation). Bipolar operation will increase nonlinearity and hysteresis.
6. TCR is resistance change with temperature with no applied field. TCOI is the output change with temperature using a constant current source to power the sensor. TCOV is the output change with temperature using a constant voltage source to power the sensor. See the graphs below.
7. Beta (β) is any angle deviation from the sensitive axis.

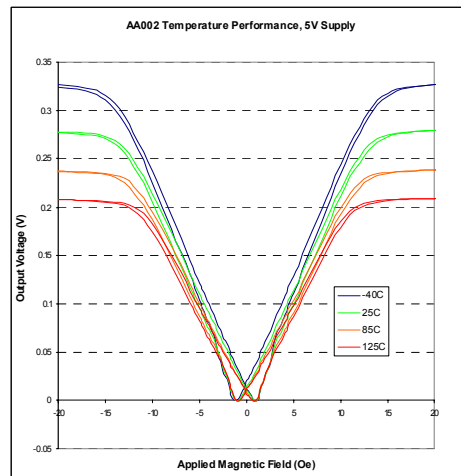
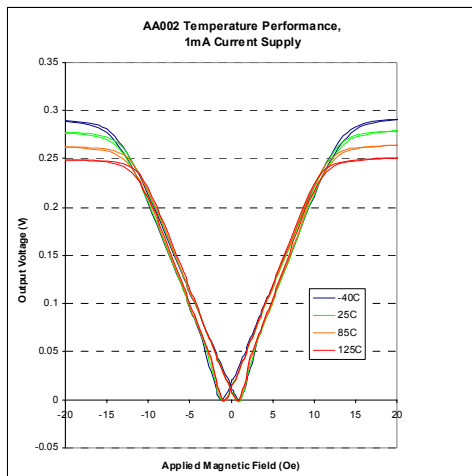

## AAH Sensors

### Features:

- Extremely High Sensitivity to Applied Magnetic Fields
- Wheatstone Bridge Analog Output
- Temperature Tolerance to 150°C Continuous
- Near-Zero Voltage Operation
- DC to >1MHz Frequency Response
- Small, Low-Profile Surface Mount Packages

### Applications:

- Low Voltage, High Temperature Applications
- Low Field Sensing for Magnetic Media Detection
- Earth's Magnetic Field Detection
- Current Sensing

### Description:

The AAH-Series GMR sensors are manufactured with a high sensitivity GMR material, making them ideally suited for any low magnetic field application. They are also extremely temperature tolerant, to +150°C operating temperatures.

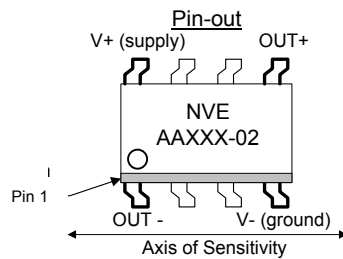

Functional Block Diagram

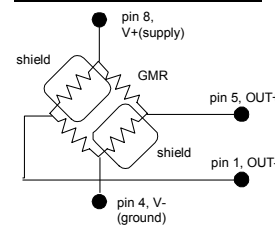

### Magnetic Characteristics:

Part Number	Saturation Field (Oe <sup>1</sup> )	Linear Range ((Oe <sup>1</sup> ))		Sensitivity (mV/V-Oe <sup>1</sup> )		Resistance (Ohms)	Package <sup>2</sup>	Die Size <sup>3</sup> (µm)
		Min	Max	Min	Max			
AAH002-02	6	0.6	3.0	11.0	18.0	2K ±20%	SOIC8	436x3370
AAH004-00	15	1.5	7.5	3.2	4.8	2K ±20%	MSOP	411x1458

**General Characteristics:**

Parameter	Min	Typical	Max	Unit
Input Voltage Range	<1 <sup>4</sup>		±12 <sup>4</sup>	Volts
Operating Frequency	DC		>1	MHz
Operating Temperature Range	-50		150	°C
Bridge Electrical Offset	-5		+5	mV/V
Signal Output at Max. Field		40		mV/V
Nonlinearity		4		% (unipolar) <sup>5</sup>
Hysteresis		15		% (unipolar) <sup>5</sup>
TCR		+0.11		% / °C <sup>6</sup>
TCOI		+0.10		% / °C <sup>6</sup>
TCOV		0.0		% / °C <sup>6</sup>
Off Axis Characteristic		Cos β <sup>7</sup>		
ESD Tolerance		400		V pin-to-pin HBM

**Notes:**

1. 1 Oersted (Oe) = 1 Gauss in air.
2. See the Appendix for package dimensions and tolerances.
3. Sensors can be provided in die form by special request.
4. GMR AAH-Series sensors are pure ratiometric devices meaning that they will operate properly at extremely low supply voltages. The output signal will be proportional to the supply voltage. Maximum voltage range is limited by the power dissipation in the package and the maximum operating temperature of the sensor.
5. Unipolar operation means exposure to magnetic fields of one polarity, e.g. 0 to 30 Gauss, or -2 to -50 Gauss, but not -20 to +30 Gauss (bipolar operation). Bipolar operation will increase nonlinearity and hysteresis.
6. TCR is resistance change with temperature with no applied field. TCOI is the output change with temperature using a constant current source to power the sensor. TCOV is the output change with temperature using a constant voltage source to power the sensor.
7. Beta (β) is any angle deviation from the sensitive axis.

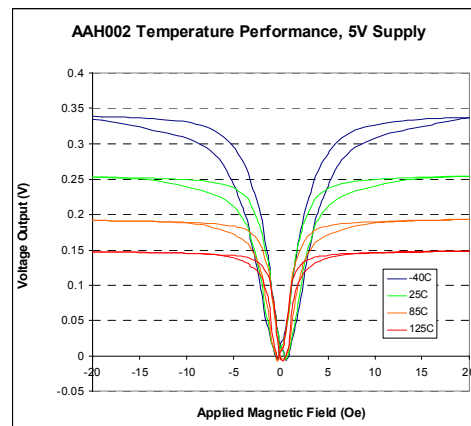
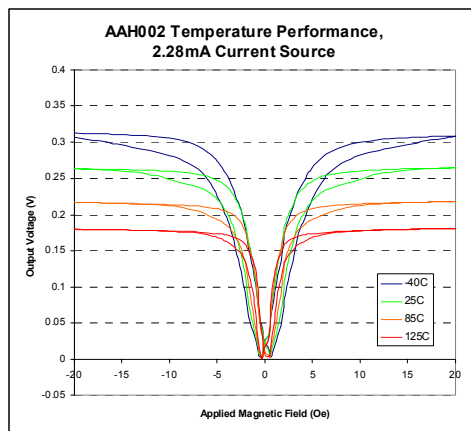

## AAL Sensors

### Features:

- Excellent Sensitivity to Applied Magnetic Fields
- Wheatstone Bridge Analog Output
- Temperature Tolerance to 150°C Continuous
- Very Low Magnetic Hysteresis
- Near-Zero Voltage Operation
- DC to >1MHz Frequency Response
- Small, Low-Profile Surface Mount Packages

### Applications:

- General Motion, Speed, and Position Sensing
- Low Voltage, High Temperature Applications
- Low Field Sensing for Magnetic Media Detection
- Current Sensing

### Description:

The AAL-Series GMR sensors are manufactured with a low hysteresis GMR material, for use in magnetometer applications where minimum hysteresis is important. They are also extremely temperature tolerant, to +150°C operating temperatures.

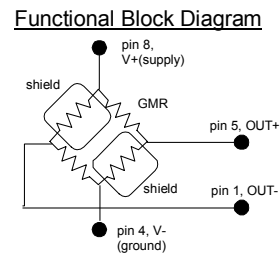
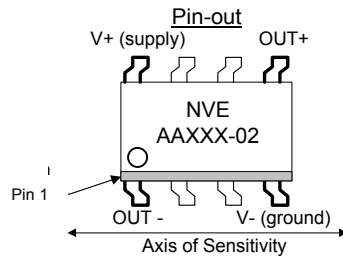

### Magnetic Characteristics:

Part Number	Saturation Field (Oe <sup>1</sup> )	Linear Range ( Oe <sup>1</sup> )		Sensitivity (mV/V-Oe <sup>1</sup> )		Resistance (Ohms)	Package <sup>2</sup>	Die Size <sup>3</sup> (µm)
		Min	Max	Min	Max			
AAL002-02	15	1.5	10.5	3.0	4.2	5.5K ±20%	SOIC8	436x3370

**General Characteristics:**

Parameter	Min	Typical	Max	Unit
Input Voltage Range	<1 <sup>4</sup>		±25 <sup>4</sup>	Volts
Operating Frequency	DC		>1	MHz
Operating Temperature Range	-50		150	°C
Bridge Electrical Offset	-4		+4	mV/V
Signal Output at Max. Field		45		mV/V
Nonlinearity			2	% (unipolar) <sup>5</sup>
Hysteresis			4	% (unipolar) <sup>5</sup>
TCR		+0.11		% / °C <sup>6</sup>
TCOI		-0.28		% / °C <sup>6</sup>
TCOV		-0.40		% / °C <sup>6</sup>
Off Axis Characteristic		Cos β <sup>7</sup>		
ESD Tolerance		400		V pin-to-pin HBM

**Notes:**

1. 1 Oersted (Oe) = 1 Gauss in air.
2. See the Appendix for package dimensions and tolerances.
3. Sensors can be provided in die form by special request.
4. GMR AAL-Series sensors are pure ratiometric devices meaning that they will operate properly at extremely low supply voltages. The output signal will be proportional to the supply voltage. Maximum voltage range is limited by the power dissipation in the package and the maximum operating temperature of the sensor.
5. Unipolar operation means exposure to magnetic fields of one polarity, e.g. 0 to 30 Gauss, or -2 to -50 Gauss, but not -20 to +30 Gauss (bipolar operation). Bipolar operation will increase nonlinearity and hysteresis.
6. TCR is resistance change with temperature with no applied field. TCOI is the output change with temperature using a constant current source to power the sensor. TCOV is the output change with temperature using a constant voltage source to power the sensor.
7. Beta (β) is any deviation angle from the sensitive axis.

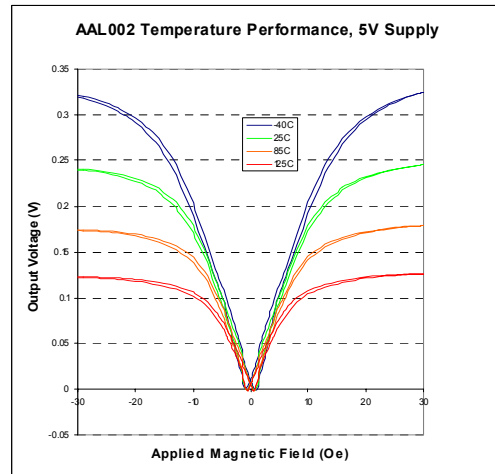
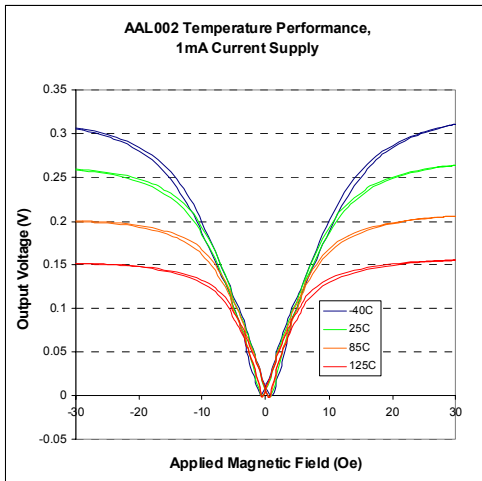

## AAV Sensors

### Features:

- Operates in Magnetic Saturation, 30 to 200 Gauss
- Half-Bridge or Individual Resistor Configurations
- Sine and Cosine Outputs Available
- Utilizes Spin Valve GMR Material
- Precise Detection of Magnetic Field
- Ultra-Small PLLP Package
- Cannot Be Damaged by Large External Magnetic Fields

### Description:

The AAV001-11 and AAV002-11 are arrays of four GMR resistors rotated at 90-degree intervals in the package. The AAV001-11 features independent resistors that can be wired together to form two half-bridges, or used as independent resistors. The AAV002-11 has the bridge connections made internally to the package. For either part, the output can be configured to represent the sine and cosine function of the magnetic field being applied to the sensor. Each resistor is 1.5 k $\Omega$  nominal resistance and output of each half-bridge is ratiometric with the power supply voltage. The part features NVE's PLLP6 housing, which is a 3.0 mm x 3.0 mm x 0.9 mm thick surface mount package.

### Operation:

The sensor elements contain two magnetic layers: a pinned, or fixed-direction layer, and a movable or free layer. The diagram below illustrates the configuration with arrows representing the two layers:

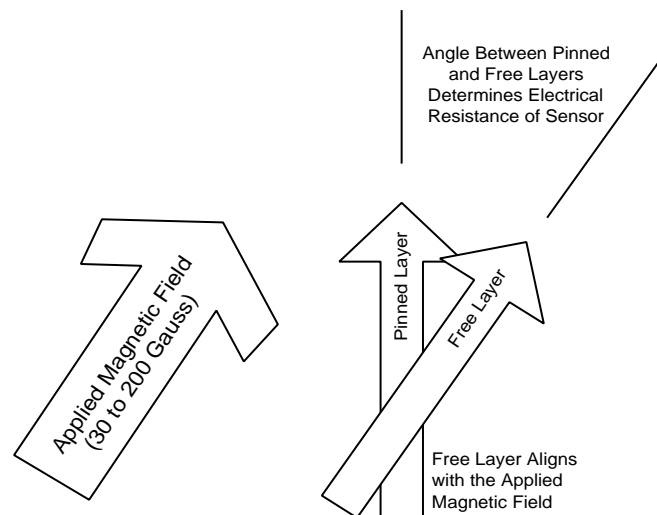

- 20 -

The end user must apply a saturating magnetic field (30 to 200 Oersteds) in the plane of the sensor in order for the sensor to operate. The movable layer will align with the applied magnetic field. As the applied field changes direction the angle between the movable layer and the pinned layer changes, resulting in a change of resistance in the device. A graph of the device resistance vs. the angle between the pinned layer and the movable layer is shown below:

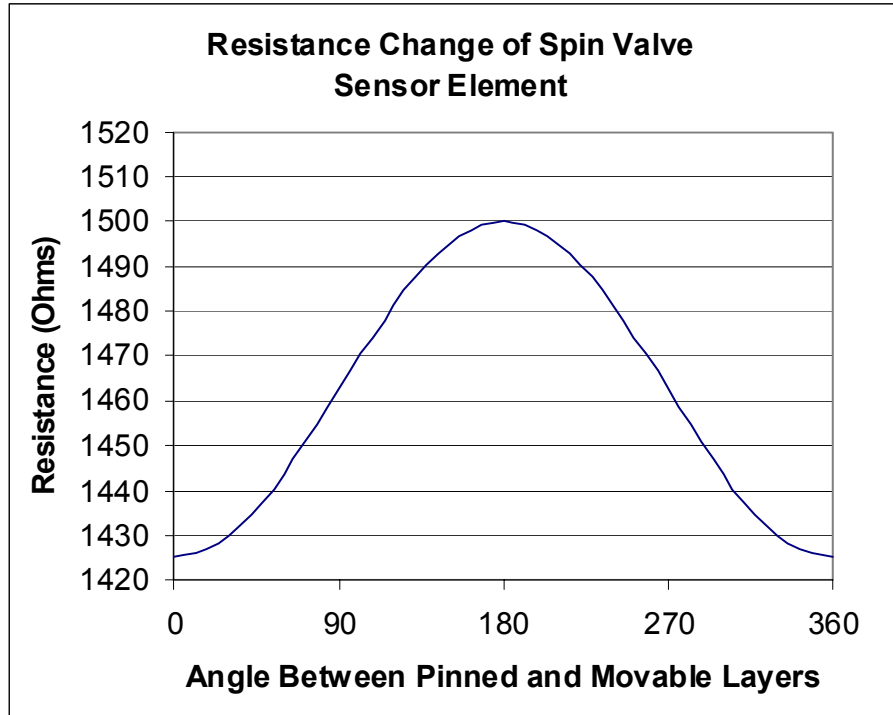

Four individual sensor resistors are supplied in the package, each with the pinned layer rotated 90° with respect to that of the previous sensor. These resistors can be connected in two half-bridge configurations to provide a sine and cosine output or monitored individually to provide an absolute indication of the angle between the pinned layer and the movable layer.

A drawing showing the ICs position in the package is given below. On each IC there is an arrow indicating the direction of the pinned layer.

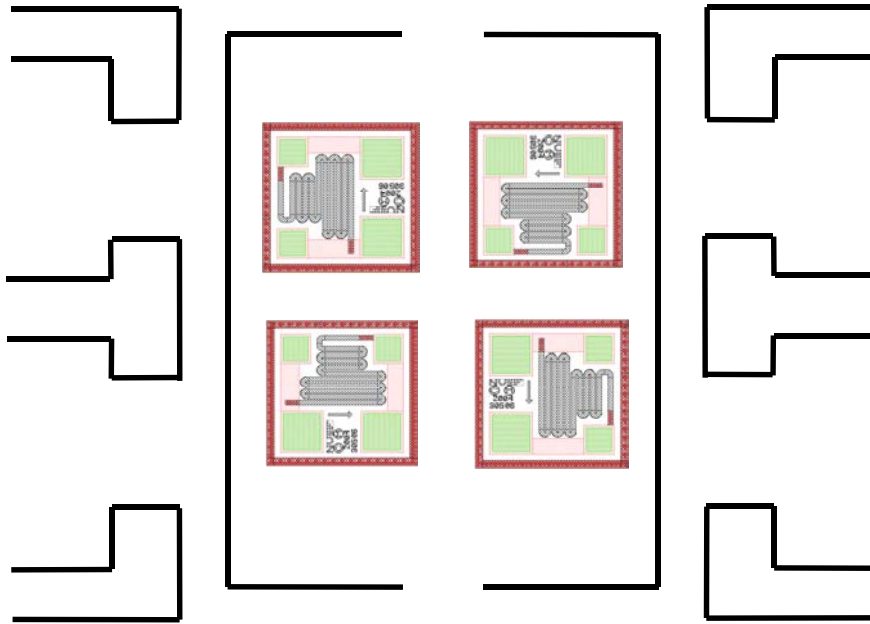

Functional Block Diagram, Marking, and Pinout, AAV001-11:

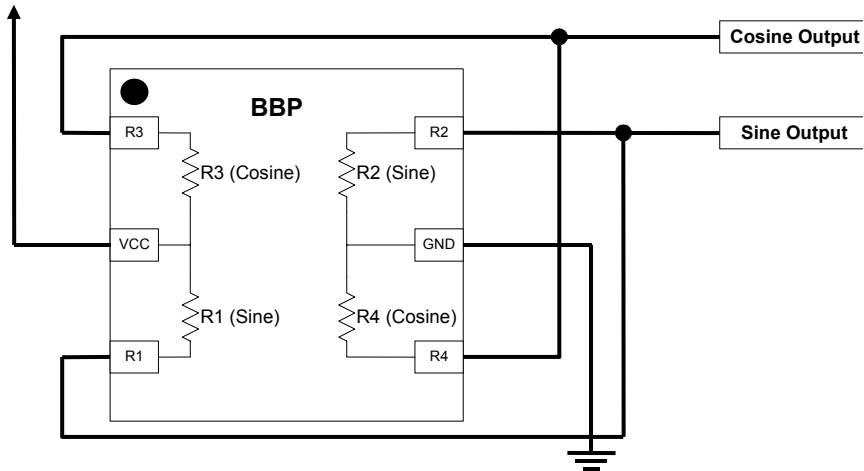

**Functional Block Diagram, Marking, and Pinout, AAV002-11:**

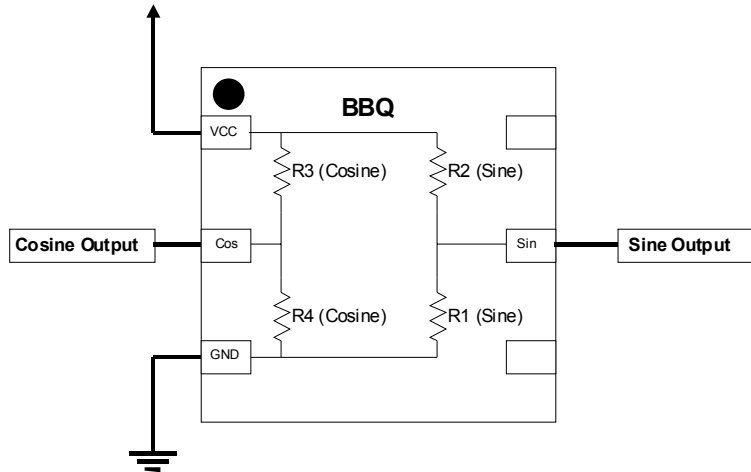

**Specifications:**

Parameter	Test Condition	Min	Typ	Max	Units
Nominal Resistance of Each Resistor	25°C	1200	1500	1800	Ohms
Maximum Resistance Decrease with Field Change	Operating at 25°C	4.5%	5.2%	7%	
Required Strength of Applied Magnetic Field	Operating	30		200	Oersted <sup>2</sup>
Measurement Error	Operating			2	Degrees
Supply Voltage	Operating			12	Volts
Offset Voltage	Operating at 25°C	-10		10	mV/V
Temperature Range of Operation	Operating	-40		150	°C
Storage Temperature		-40		170	°C
Temperature Coefficient of Resistance	Operating		+0.3		%/°C
TCOV <sup>3</sup>	Operating		-0.24		%/°C
TCOI <sup>3</sup>	Operating		-0.16		%/°C

**Notes:**

1. Large Magnetic Fields WILL NOT cause damage to NVE GMR Sensors.
2. 1 Oe (Oersted) = 1 Gauss in air = 0.1 mTesla = 79.8 Amps/meter.
3. TCOV is the percent change in output signal over temperature with a constant voltage source powering the part and TCOI is the percent change in output over temperature with a constant current source.

**AB Sensors**

**Features:**

- Excellent Sensitivity to Applied Magnetic Fields
- Wheatstone Bridge Analog Output
- Temperature Tolerance to 125°C Continuous
- Wide Linear Range of Operation
- Near-Zero Voltage Operation
- DC to >1MHz Frequency Response
- Small, Low-Profile Surface Mount Packages

**Applications:**

- General Differential Field Sensing
- Gear Tooth and Encoder Speed and Position Sensing
- Low Power, Low Voltage Applications

**Description:**

The AB-Series GMR sensors are general-purpose gradiometers for use in a wide variety of applications. Two pairs of unshielded GMR sensor elements provide for directional sensing of small gradients in large and small magnetic fields. The ability to detect only magnetic gradients allows low sensitivity to external sources of uniform magnetic field allowing these sensors to work successfully in high magnetic noise environments such as near electric motors or current carrying wires.

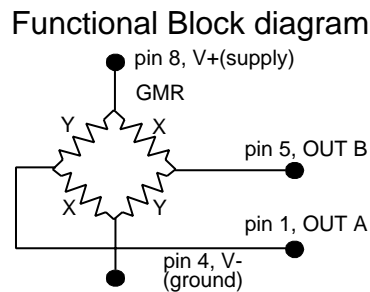
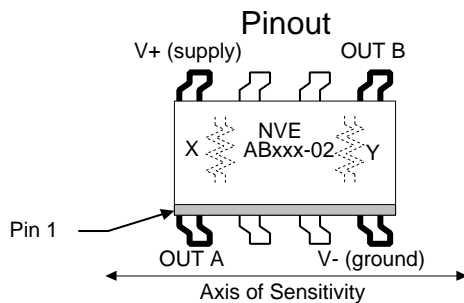

**Magnetic Characteristics:**

Part Number	Saturation Field (Oe <sup>1</sup> )	Linear Range (Oe <sup>1</sup> )		Resistor Sensitivity (%R / Oe <sup>1</sup> )		Resistance (Ohms)	Package <sup>2</sup>	Die Size <sup>3</sup> (µm)
		Min	Max	Min	Max			
AB001-02	250	10	175	0.02	0.03	2.5K ±20%	SOIC8	651x1231
AB001-00	250	10	175	0.02	0.03	2.5K ±20%	MSOP8	651x1231

**General Characteristics:**

Parameter	Min	Typical	Max	Unit
Input Voltage Range	<1 <sup>4</sup>		±12.5 <sup>4</sup>	Volts
Operating Frequency	DC		>1	MHz
Operating Temperature Range	-50		125	°C
Bridge Electrical Offset	-4		+4	mV/V
Signal Output at Max. Field		120		mV/V
Nonlinearity			2	% (unipolar) <sup>5</sup>
Hysteresis			4	% (unipolar) <sup>5</sup>
TCR		+0.14		% / °C <sup>6</sup>
TCOI		+0.03		% / °C <sup>6</sup>
TCOV		-0.1		% / °C <sup>6</sup>
Off Axis Characteristic		Cos β <sup>7</sup>		
ESD Tolerance		400		V pin-to-pin HBM

**Notes:**

1. 1 Oersted (Oe) = 1 Gauss in air.
2. See the Appendix for package dimensions and tolerances.
3. Sensors can be provided in die form by special request.
4. GMR AB-Series sensors are pure ratiometric devices, meaning that they will operate properly at extremely low supply voltages. The output signal will be proportional to the supply voltage. Maximum voltage range is limited by the power dissipation in the package and the maximum operating temperature of the sensor.
5. Unipolar operation means exposure to magnetic fields of one polarity, e.g., 0 to 30 Gauss, or -2 to -50 Gauss, but not -20 to +30 Gauss (bipolar operation). Bipolar operation will increase nonlinearity and hysteresis.
6. TCR is resistance change with temperature with no applied field. TCOI is the output change with temperature using a constant current source to power the sensor. TCOV is the output change with temperature using a constant voltage source to power the sensor.
7. Beta (β) is any angle deviation from the sensitive axis.

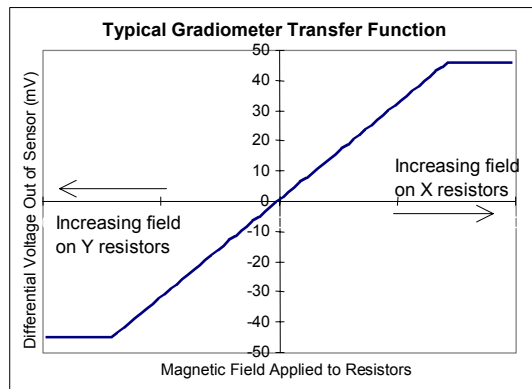

The Figure at left is a simulated output from an NVE Gradiometer. The output / gradient correlation shown assumes one pair of resistors is held at zero field. Note the bipolar output.

**ABH Sensors**

**Features:**

- Extremely High Sensitivity to Applied Magnetic Fields
- Wheatstone Bridge Analog Output
- Temperature Tolerance to 150°C Continuous
- Wide Linear Range of Operation
- Near-Zero Voltage Operation
- DC to >1MHz Frequency Response
- Small, Low-Profile Surface Mount Packages

**Applications:**

- General Differential Field Sensing
- Gear Tooth and Encoder Speed and Position Sensing
- Low Voltage, High Temperature Applications

**Description:**

The ABH-Series GMR sensors are low field, high temperature gradiometers for use in a wide variety of applications. Two pairs of unshielded GMR sensor elements provide for directional sensing of small gradients in large and small magnetic fields. The ability to detect only magnetic gradients allows low sensitivity to external sources of uniform magnetic field allowing these sensors to work successfully in high magnetic noise environments such as near electric motors or current carrying wires.

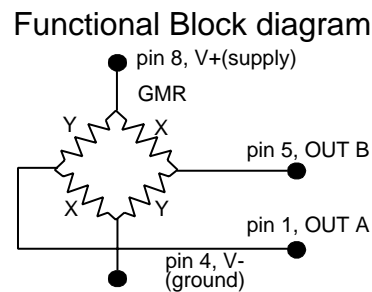
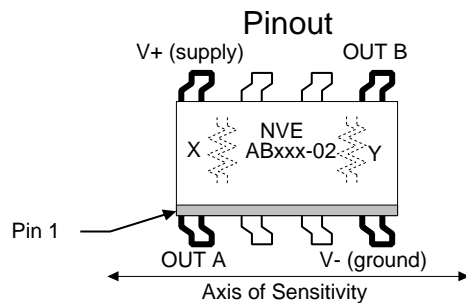

**Magnetic Characteristics:**

Part Number	Saturation Field (Oe <sup>1</sup> )	Linear Range ( Oe <sup>1</sup>  )		Resistor Sensitivity (%R / Oe <sup>1</sup> )		Resistance (Ohms)	Package <sup>2</sup>	Die Size <sup>3</sup> (µm)
		Min	Max	Min	Max			
ABH001-00	70	5	40	0.06	0.12	1.2K ±20%	MSOP8	651x1231

**General Characteristics:**

Parameter	Min	Typical	Max	Unit
Input Voltage Range	<1 <sup>4</sup>		±6 <sup>4</sup>	Volts
Operating Frequency	DC		>1	MHz
Operating Temperature Range	-50		150	°C
Bridge Electrical Offset	-4		+4	mV/V
Signal Output at Max. Field		80		mV/V
Nonlinearity			4	% (unipolar) <sup>5</sup>
Hysteresis			15	% (unipolar) <sup>5</sup>
TCR		+0.11		% / °C <sup>6</sup>
TCOI		+0.10		% / °C <sup>6</sup>
TCOV		0.0		% / °C <sup>6</sup>
Off Axis Characteristic		Cos β <sup>7</sup>		
ESD Tolerance		400		V pin-to-pin HBM

**Notes:**

- 1 Oersted (Oe) = 1 Gauss in air.
- 2 See the Appendix for package dimensions and tolerances.
- 3 Sensors can be provided in die form by special request.
- 4 GMR AB-Series sensors are pure ratiometric devices meaning that they will operate properly at extremely low supply voltages. The output signal will be proportional to the supply voltage. Maximum voltage range is limited by the power dissipation in the package and the maximum operating temperature of the sensor.
- 5 Unipolar operation means exposure to magnetic fields of one polarity, e.g., 0 to 30 Gauss, or -2 to -50 Gauss, but not -20 to +30 Gauss (bipolar operation). Bipolar operation will increase nonlinearity and hysteresis.
- 6 TCR is resistance change with temperature with no applied field. TCOI is the output change with temperature, using a constant current source to run the sensor. TCOV is the output change with temperature, using a constant voltage source to run the sensor.
- 7 Beta (β) is any angle deviation from the sensitive axis.

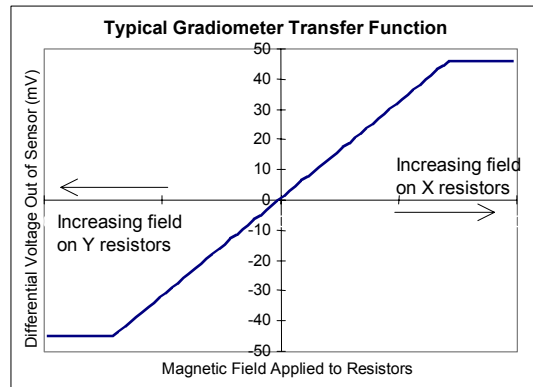

The Figure at left is a simulated output from an NVE Gradiometer. The output / gradient correlation shown assumes one pair of resistors is held at zero field. Note the bipolar output.

**GMR Switch Precision Digital Sensors**

When GMR sensor elements are combined with digital on-board signal processing electronics the result is the GMR Switch. The GMR Switch offers unmatched precision and flexibility in magnetic field sensing.

The GMR Switch will accurately and reliably sense magnetic fields with less error than any other magnetic sensor on the market today. In addition, there is little shift in the magnetic field operate point of the GMR Switch over voltage and temperature extremes. This gives NVE's customer the ability to make a high precision, high tolerance magnetic sensing assembly.

The GMR switch can operate over a wide range of magnetic fields and is the most precise magnetic sensor on the market. It is the clear choice when a digital output signal is required of a magnetic sensor.

**Operate Point Error Band for Typical Magnetic Sensors  
(4.5V to 30V, -40°C to +125°C)**

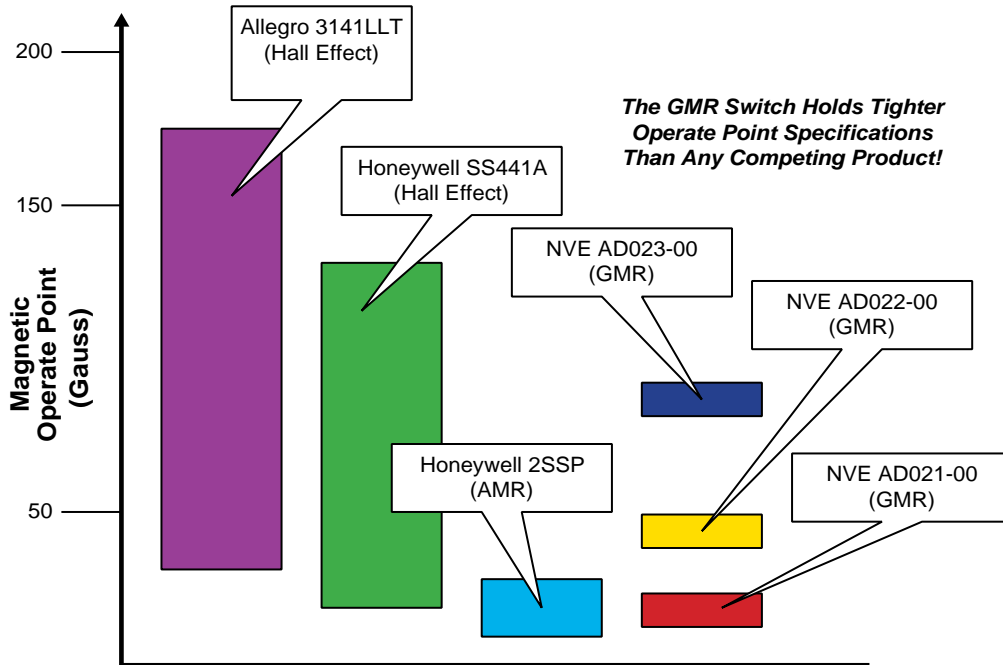

## Quick Reference: GMR Switch Digital Sensors

The following table lists some of NVE's most popular GMR Switch products and their key specifications:

Part Number	Typical Magnetic Operate Point (Oe <sup>1</sup> )	Typical Magnetic Release Point (Oe <sup>1</sup> )	Output Type <sup>2</sup>	Maximum Operation Temperature (°C)	Package Type <sup>3</sup>
NVE AD004-02	20	10	Sink	125	SOIC8
NVE AD005-02	40	25	Sink	125	SOIC8
NVE AD021-00	20	10	Sink	125	MSOP8
NVE AD022-00	40	25	Sink	125	MSOP8
NVE AD024-00	28	14	Sink	125	MSOP8
NVE AD124-00	28	14	Source	125	MSOP8
NVE AD621-00	20	10	Sink + Source+ VREG	125	MSOP8
NVE AD824-00	28	14	2 Sinks + SCP	125	MSOP8
NVE ADH025-00	11	5	Sink	150	MSOP8

### Notes:

- 1 Oersted (Oe) = 1 Gauss in air
- 2 Output Types:  
Sink = Up to 20 mA current sink  
Source = Up to 20 mA current source  
SCP = Short Circuit Protection available for external transistor
- 3 See Appendix for package dimensions

### Note on Availability of Products

NVE keeps about 25 of the most popular types of GMR Switch products in stock at our manufacturing facility. However, because there are over 100 different varieties of GMR Switch parts, some part numbers may require a six to eight week lead time before production quantities are available. Please contact NVE for further information.

## GMR Switch Product Selection Guide

NVE’s GMR Switch is available in a wide range of packaging, output type, and magnetic trigger field varieties. The purpose of this selection guide is to explain the different output and packaging options, as well as to provide information on how to specify the correct part number when ordering.

All NVE GMR Switch product part numbers follow the same general form. As shown below, the first “x” in the part number specifies output type and available voltage regulator output, the next two x’s specify trigger field and direction of sensitivity, and the last pair specify the package type. The following sections define these variations in detail.

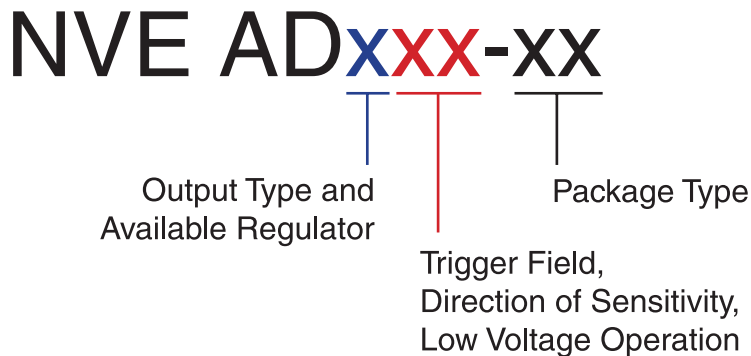

### **Output Type and Available Regulator**

The first numeric digit of the part number NVE ADxxx-xx specifies the output type, and the availability of a regulated voltage supply on a separate pin. The following four output types are available:

- 20 mA Current Sink
- 20 mA Current Source
- Separate 20 mA Sink and Source
- Two Separate 20 mA Sinks

All outputs turn ON when the magnetic field is applied. An output that turns OFF when the magnetic field is applied is available as a custom product; please consult NVE.

Some of NVE’s GMR Switches also feature a regulated supply voltage available external to the part on a separate pin. This regulator provides a 5.8V reference capable of supplying up to 3 mA of drive current. This regulated output may be used to run an LED or other low power device.

In addition to these options, NVE recently introduced a GMR Switch that has provisions for shutting down an external power transistor in case a short circuit is detected. This is useful in applications where the finished sensor assembly must be “bulletproof,” or immune to improper connection.

The following table defines the first digit in the NVE AD part number:

**NVE AD x xx-xx**

Number	Output Configuration
0	20mA Current Sink
1	20 mA Current Source
2	Separate 20mA Current Sink and 20mA Current Source
3	Two Separate 20mA Current Sinks
4	20mA Current Sink + Regulated Output Voltage
5	20 mA Current Source + Regulated Output Voltage
6	Separate 20mA Current Sink and 20mA Current Source + Regulated Output Voltage
7	Two Separate 20mA Current Sinks + Regulated Output Voltage
8	Two Separate 20mA Current Sinks + Regulated Output Voltage + Short Circuit Detection and Shut-Off
9	Separate 20mA Current Sink and 20mA Current Source + Regulated Output Voltage + Short Circuit Detection and Shut-Off

### ***Trigger Field, Direction of Sensitivity, Low Voltage Operation***

The second and third numeric digits of the part number NVE ADxxx-xx specify the magnetic trigger field and direction of sensitivity of the part. Five different magnetic trigger fields are available for the GMR Switch:

- 10 Gauss (10 Oe, 1.0 mT, 0.8 kA/m)
- 20 Gauss (20 Oe, 2.0 mT, 1.6 kA/m)
- 28 Gauss (28 Oe, 2.8 mT, 2.23 kA/m)
- 40 Gauss (40 Oe, 4.0 mT, 3.2 kA/m)
- 80 Gauss (80 Oe, 8.0 mT, 6.4 kA/m)

Other magnetic trigger field levels ranging up to 250 Gauss are available on a custom basis; please contact NVE.

In addition to defining the magnetic operate point; these two digits are used to define the direction of sensitivity and optional low voltage operation. The GMR Switch can be ordered in Standard Axis or Cross Axis directions of sensitivity. For definitions please see NVE AD Series Sensitivity Direction and Pin Configuration later in this section.

NVE also makes a GMR Switch with the on-chip voltage regulator bypassed. This limits the voltage range of the part, but allows it to operate at voltages as low as 3.0V.

The following table defines the second and third digits in the NVE AD part number:

## NVE AD x **xx**-xx

Number	Configuration
04	20 Gauss OP, Standard Direction of Sensitivity
05	40 Gauss OP, Standard Direction of Sensitivity
06	80 Gauss OP, Standard Direction of Sensitivity
20	28 Gauss OP, Standard Direction of Sensitivity
21	20 Gauss OP, Cross Axis Direction of Sensitivity
22	40 Gauss OP, Cross Axis Direction of Sensitivity
23	80 Gauss OP, Cross Axis Direction of Sensitivity
24	28 Gauss OP, Cross Axis Direction of Sensitivity
25	10 Gauss OP, Cross Axis Direction of Sensitivity (ADH Series Only; see page 38)
81	20 Gauss OP, Cross Axis Direction of Sensitivity, Low Volt
82	40 Gauss OP, Cross Axis Direction of Sensitivity, Low Volt
83	80 Gauss OP, Cross Axis Direction of Sensitivity, Low Volt
84	28 Gauss OP, Cross Axis Direction of Sensitivity, Low Volt

**Note:** For parts that operate at 10 Gauss, see the following section describing the NVE ADH-Series sensors.

### NVE AD-Series Sensitivity Direction and Pin Configuration

Pin configuration for the NVE AD-Series GMR Switches is given in the following diagrams. In addition, most GMR Switch parts are available with a choice of two directions of sensitivity. “Standard” direction of sensitivity is defined as the direction parallel to the edge of the package containing the pins. “Cross-Axis” direction of sensitivity is defined as the direction perpendicular to the edge of the package containing the pins. Pin configuration and sensitivity direction is defined in the drawings below:

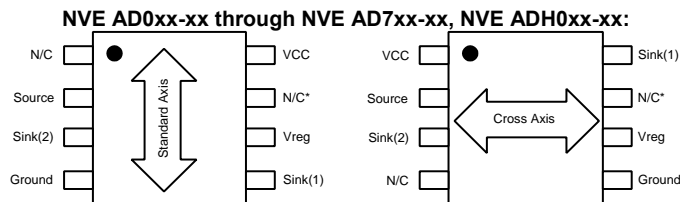

**Note:** In the case of a Standard Axis Part with the Vreg pin option, Sink(1) will appear at the pin labelled N/C\*

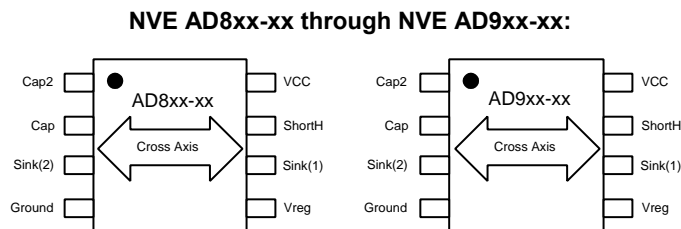

**Package Type**

NVE GMR Switches are available in three different packages: an SOIC 8-pin package, an MSOP 8-pin small outline package, and a TDFN 6 pin ultra-miniature package. Package drawings are shown in the Appendix.

The following table defines the last two digits in the NVE AD part number:

Number	Package Type
00	MSOP8
02	SOIC8
10 <sup>1</sup>	TDFN6

<sup>1</sup>At this time, the TDFN6 package is only available in AD0xx-10 configuration.

In addition to these three package types, NVE offers a custom version of the MSOP8 package for the NVE AD024-00 part. In this version, the BD012-00, all three connections are made on one side of the package, and the pins on the other side of the package are clipped off flush with the body of the package. This allows the user to position the sensing element as close to the edge of a circuit board or assembly as possible. A pinout of this package is shown below:

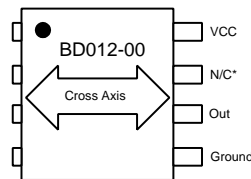

The maximum length of the clipped leads is 0.30 mm leading to an overall package length of 4.25 mm, as compared to 4.90 mm for the normal MSOP8 package. This part is available in tape and reel format only.

Other versions of the GMR Switch may be available in this package configuration on a special order basis. Please contact NVE for further information.

**Characteristics Over Voltage and Temperature**

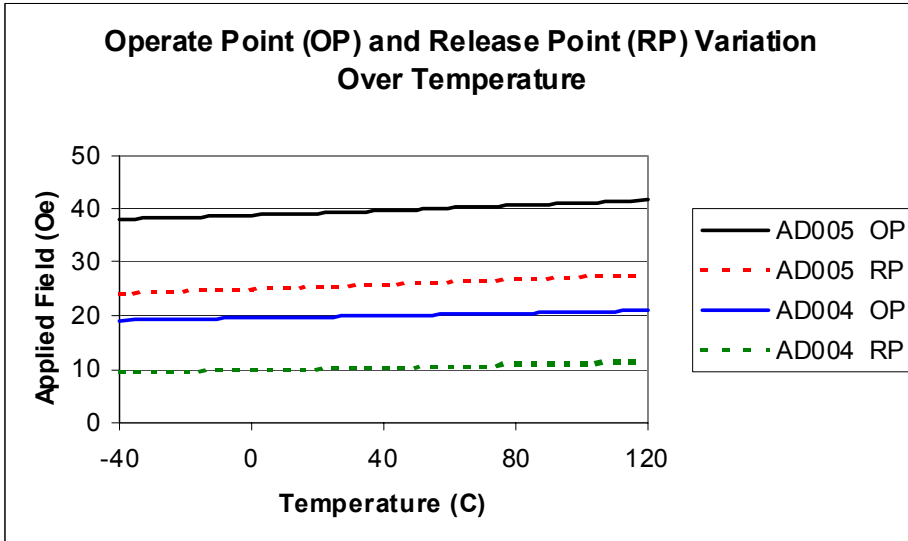
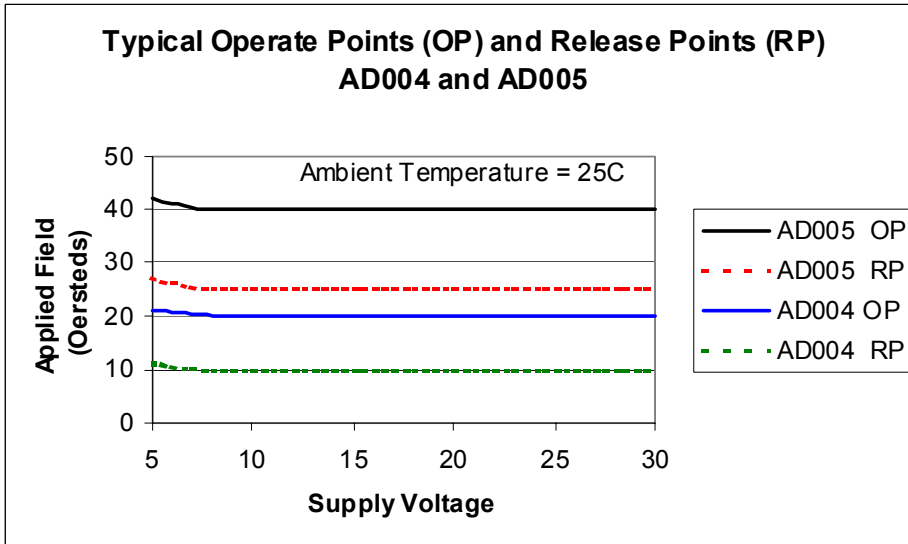

**Operating Temperature Derating Curves for SOIC8,  
MSOP8, and TDFN6 Packages in Free Air**

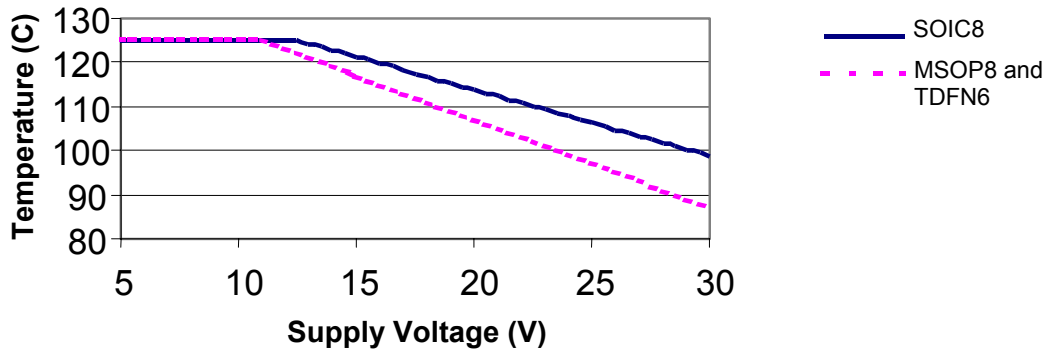

**Output Current Derating Curve**

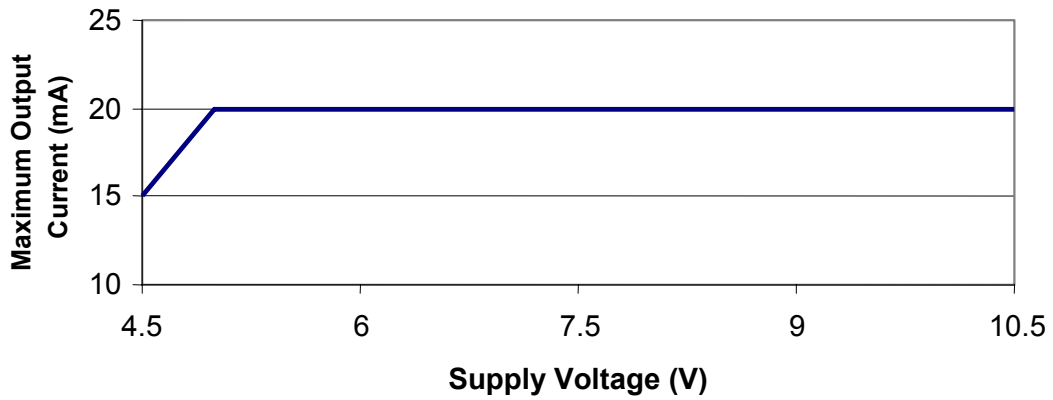

**AD0xx-xx to AD7xx-xx**

**Features:**

- Precision Magnetic Operate Point
- Excellent Temperature and Voltage Performance
- Digital Outputs
- Frequency Response 0 to 250kHz
- Optional Voltage Regulator Output
- Optional Low Voltage Version
- Small, Low-Profile Surface Mount Packages

**Applications:**

- General Digital Position Sensing
- Pneumatic Cylinder Position Sensing
- Speed Sensing

**Description:**

The NVE AD0xx-xx to AD7xx-xx GMR Switches are digital output magnetometers that offers precision operate points over all temperature and input voltage conditions. They are available with magnetic trigger fields from 20 to 80 Gauss and four different output configurations, making them an extremely flexible and user-friendly design.

**Functional Block Diagram (NVE AD0xx-xx to NVE AD7xx-xx, (Except NVE AD08x-xx):**

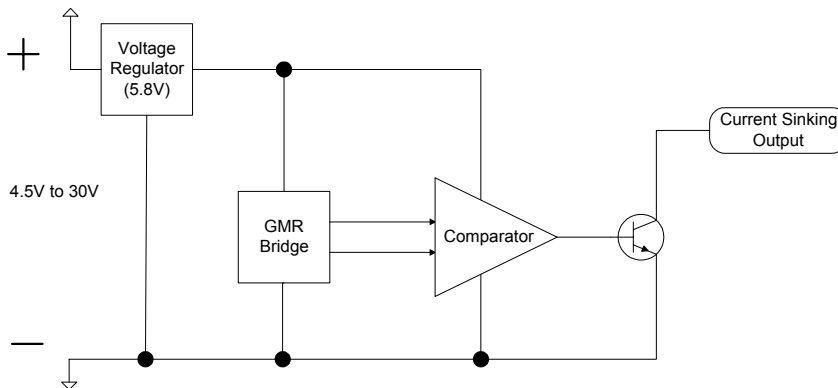

**Functional Block Diagram (NVE AD08x-xx):**

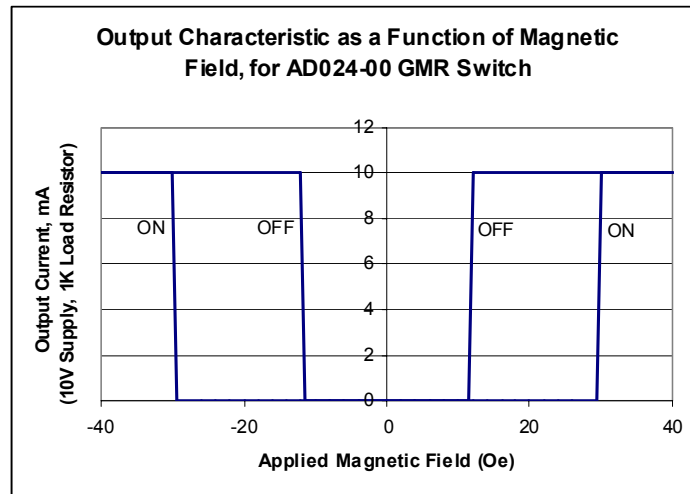
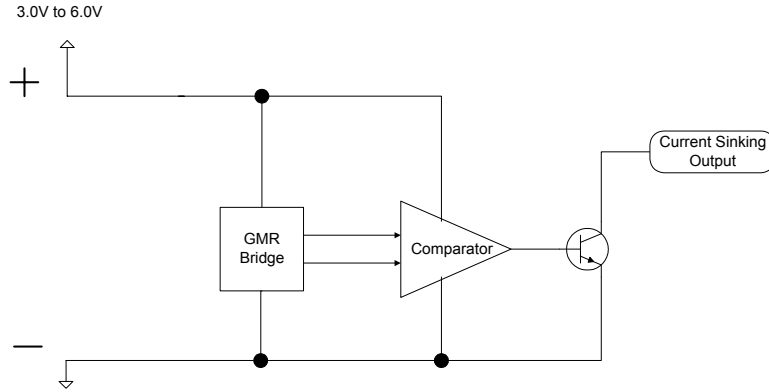

**Magnetic Characteristics:**

Typical Operate Point	Minimum Operate Point	Maximum Operate Point	Minimum Differential <sup>1,2</sup>	Maximum Differential <sup>1,2</sup>
20	15	25	5	14
28	21	34	5	20
40	30	50	5	25
80	60	100	5	35

Note: All Values in Oersteds (Oe); 1 Oe = 1 Gauss in Air

## Electrical Specifications

(NVE AD0xx-xx to NVE AD7xx-xx, except NVE AD08x-xx):

Parameter	Symbol	Min	Max	Units	Test Condition
Supply Voltage <sup>4</sup>	V <sub>CC</sub>	4.5	30	V	Operating
Supply Current, Single Output	I <sub>CC</sub>	2.5	4.5	mA	Output Off, V <sub>CC</sub> =12V
Current Sinking Output <sup>3</sup>	I <sub>O</sub>	0	20	mA <sup>3</sup>	Operating
Current Sourcing Output <sup>3</sup>	I <sub>O</sub>	0	20	mA <sup>3</sup>	Operating
Output Leakage Current	I <sub>LEAK</sub>		10	μA	Output Off, V <sub>CC</sub> =12V
Sinking Output Saturation Voltage	V <sub>OL</sub>		0.4	V	Output On, I <sub>OL</sub> =20mA
Sourcing Output Saturation Voltage	V <sub>OH</sub>		V <sub>CC</sub> -2.5	V	Output On, I <sub>OL</sub> =20mA
Regulated Output Voltage <sup>5</sup>	V <sub>REG</sub>	3.5	6.2	V	Operating
Regulated Output Current	I <sub>REG</sub>		3.0	mA	Operating

## Electrical Specifications (NVE AD08x-xx):

Parameter	Symbol	Min	Max	Units	Test Condition
Supply Voltage	V <sub>CC</sub>	3.0	6.0	V	Operating
Supply Current	I <sub>CC</sub>	0.7	1.2	mA	Output Off, V <sub>CC</sub> =3V
Supply Current	I <sub>CC</sub>	1.7	2.2	mA	Output Off, V <sub>CC</sub> =6V
Current Sinking Output <sup>3</sup>	I <sub>O</sub>	0	20	mA <sup>3</sup>	Operating
Output Leakage Current	I <sub>LEAK</sub>		10	μA	Output Off, V <sub>CC</sub> =5V
Sinking Output Saturation Voltage	V <sub>OL</sub>		0.4	V	Output On, I <sub>OL</sub> =20mA

## Absolute Maximum Ratings

(NVE AD0xx-xx to NVE AD7xx-xx, except NVE AD08x-xx):

Parameter	Symbol	Min	Max	Units
Supply Voltage	V <sub>CC</sub>		33	V
Reverse Battery Voltage	V <sub>RBP</sub>		-33	V
Current Sinking Output Off Voltage			33	V
Current Sourcing Output Off Voltage			0	V
Current Sinking Reverse Output Voltage			-0.5	V
Current Sourcing Reverse Output Voltage			-0.5	V
Output Current	I <sub>O</sub>		24	mA
Operating Temperature Range <sup>4</sup>	T <sub>A</sub>	-40	125	°C
Storage Temperature Range	T <sub>S</sub>	-65	150	°C
Magnetic Field <sup>5</sup>	H		None	Oe

## Absolute Maximum Ratings (NVE AD08x-xx):

Parameter	Symbol	Min	Max	Units
Supply Voltage	$V_{CC}$		7	V
Reverse Battery Voltage	$V_{RBP}$		-0.5	V
Current Sinking Output Off Voltage			33	V
Current Sinking Reverse Output Voltage			-0.5	V
Output Current	$I_0$		24	mA
Operating Temperature Range <sup>4</sup>	$T_A$	-40	125	°C
Storage Temperature Range	$T_S$	-65	150	°C
Magnetic Field <sup>5</sup>	H		None	Oe

### Notes:

1. Differential = Operate Point - Release Point
2. Minimum Release Point for AD0xx-xx to AD7xx-xx, except AD08x-xx, = 5 Oe. Minimum Release Point for AD08x-xx = 3.5 Oe.
3. Output current must be limited by a series resistor. Exceeding absolute maximum continuous output current ratings will result in damage to the part. See the figure in the GMR Switch Product Selection Guide for an output current derating curve.
4. Thermal power dissipation for the packages used by NVE is 240°C/Watt for the SOIC8 package, and 320°C/Watt for the MSOP8 and TDFN6 packages. See the Figure on Ambient Temperature vs. Supply Voltage for derating information. Heat sinking the parts by attaching them to a PCB improves temperature performance.
5. There is no maximum magnetic field that will cause damage to the device.
6. If  $V_{CC} > 6.6V$ ,  $V_{REG} = 5.8V$ . If  $V_{CC} < 6.6V$ ,  $V_{REG} = V_{CC} - 0.9V$ .

## AD8xx-xx to AD9xx-xx

### Features:

- Short Circuit Detection and Shutoff of External Power Transistor
- Precision Magnetic Operate Point
- Excellent Temperature and Voltage Performance
- Digital Outputs
- Frequency Response 0 to 250kHz
- Small, Low-Profile Surface Mount Packages

### Applications:

- General Digital Position Sensing
- Pneumatic Cylinder Position Sensing
- Speed Sensing

### Description:

NVE AD8xx and AD9xx GMR Switches are designed specifically for use with an external high current output transistor in industrial control environments. These parts provide the same precise magnetic performance NVE's GMR Switch is known for with the additional functionality of short circuit protection (SCP) for the output stage of the circuit. The protection circuit is designed to shut off the output stage when a short circuit condition exists. After a user-specified time interval, the circuit turns back on. If the short circuit condition still exists, the output stage is again shut off and the cycle repeats. This sensor, along with external reverse battery protection and overvoltage protection, results in a "bulletproof" sensor assembly. A functional block diagram of this sensor is shown below:

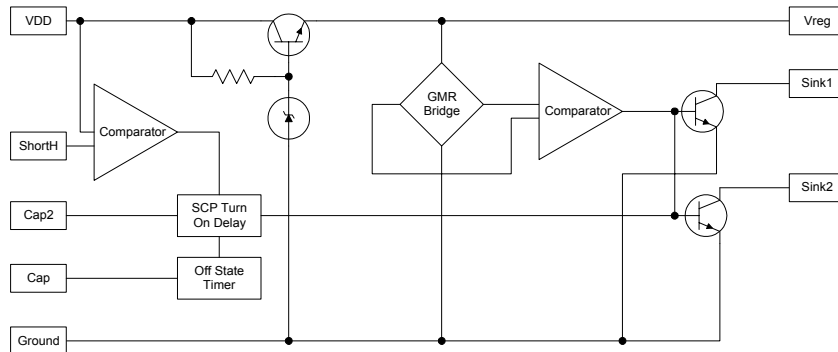

These digital sensors with SCP are available for use with current sinking or current sourcing outputs, in a range of magnetic field operate points. They are provided in an MSOP8 package with the cross-axis direction of sensitivity. An LED driver to indicate the presence of the magnetic field is also standard on these products. An SOIC8 package and standard axis sensitivity are available on a special order basis.

**Typical Circuit Configuration:**

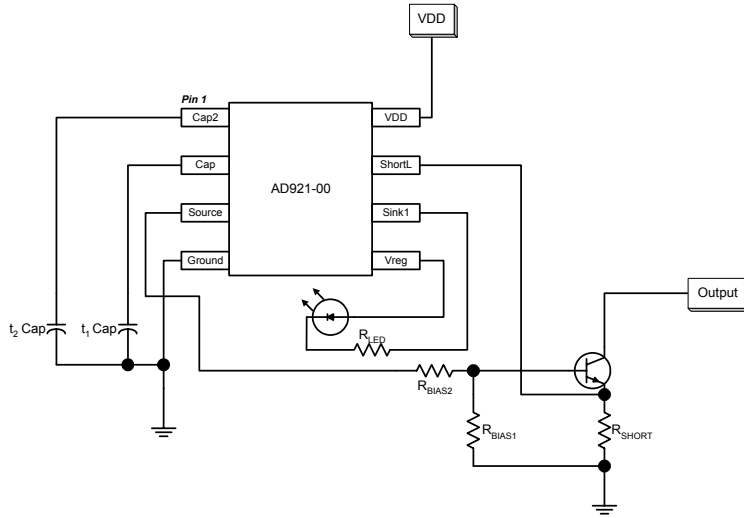
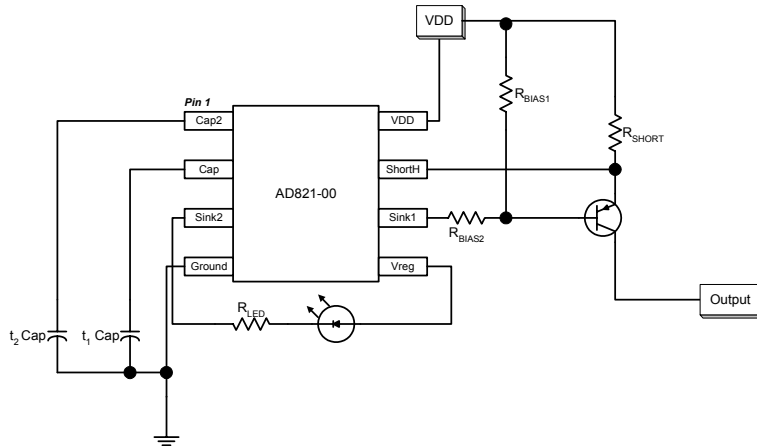

**Output Transistor Current in Short Circuit mode:**

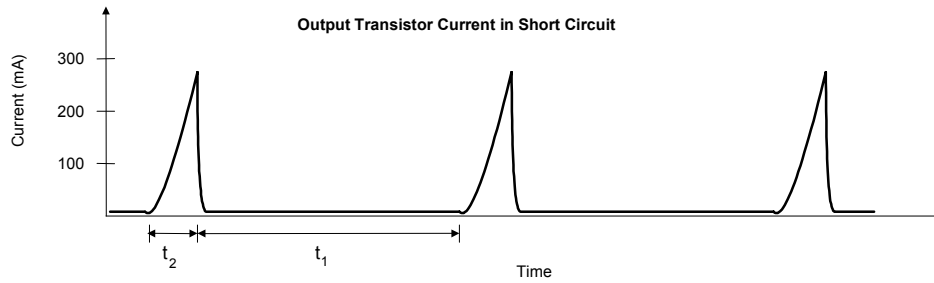

**Notes:**

1. The  $t_2$  Capacitor is used to delay the startup of the SCP circuitry in order to avoid triggering the SCP circuitry on normal startup transients: see  $t_2$  on the graph above. Typical value is 16V, 0.001 $\mu$ F, for a 35 $\mu$ s delay.
2. The  $t_1$  Capacitor is used to set the "Off" time of the SCP circuitry; see  $t_1$  on the graph above. Typical value is 16V, 0.01 $\mu$ F, for a 15 ms Off time.
3. The voltage across  $R_{SHORT}$  is monitored by the IC. If this voltage exceeds 145 mV (typical), the SCP circuitry is activated. Typical value of  $R_{SHORT}$  is 0.47 $\Omega$ , 1/16 watt. This will result in SCP circuitry turning on at about 300 mA of output current.
4.  $R_{BIAS1}$  and  $R_{BIAS2}$  are used to bias the output transistor. Typical values for  $R_{BIAS1}$  and  $R_{BIAS2}$  are 16k $\Omega$  and 3k $\Omega$ , respectively, to supply 1 mA drive to the output transistor.
5.  $R_{LED}$  is sized for whatever LED current is required by the user (maximum of 3 mA.)

**Magnetic Characteristics:**

Typical Operate Point	Minimum Operate Point	Maximum Operate Point	Minimum Differential <sup>1,2</sup>	Maximum Differential <sup>1,2</sup>
20	15	25	5	14
28	21	34	5	20
40	30	50	5	25
80	60	100	5	35

**Note: All Values in Oersteds (Oe); 1 Oe = 1 Gauss in Air**

## Electrical Specifications:

Parameter	Symbol	Min	Max	Units	Test Condition
Supply Voltage <sup>4</sup>	V <sub>CC</sub>	4.5	30	V	Operating
Supply Current	I <sub>CC</sub>	1.75	3.5	mA	Output Off, V <sub>CC</sub> =12V
Current Sinking Output <sup>3</sup>	I <sub>O</sub>	0	2.0	mA <sup>3</sup>	Operating
Current Sourcing Output <sup>3</sup>	I <sub>O</sub>	0	2.0	mA <sup>3</sup>	Operating
Output Leakage Current	I <sub>LEAK</sub>		10	μA	Output Off, V <sub>CC</sub> =12V
Sinking Output Saturation Voltage	V <sub>OL</sub>		0.4	V	Output On, I <sub>OL</sub> =2mA
Sourcing Output Saturation Voltage	V <sub>OH</sub>		V <sub>CC</sub> -2.0	V	Output On, I <sub>OL</sub> =2mA
Regulated Output Voltage <sup>5</sup>	V <sub>REG</sub>	3.5	6.0	V	Operating
Regulated Output Current	I <sub>REG</sub>		3.0	mA	Operating
Short High Voltage	ShortH	0.12	0.17	V	Output On
Short Low Voltage	ShortL	0.12	0.17	V	Output On

## Absolute Maximum Ratings:

Parameter	Symbol	Min	Max	Units
Supply Voltage	V <sub>CC</sub>		33	V
Reverse Battery Voltage	V <sub>RBP</sub>		-0.5	V
Current Sinking Output Off Voltage			33	V
Current Sourcing Output Off Voltage			0	V
Current Sinking Reverse Output Voltage			-0.5	V
Current Sourcing Reverse Output Voltage			-0.5	V
Output Current	I <sub>O</sub>		5	mA
Operating Temperature Range <sup>4</sup>	T <sub>A</sub>	-40	125	°C
Storage Temperature Range	T <sub>S</sub>	-65	135	°C
Magnetic Field <sup>5</sup>	H		None	Oe

## Notes:

1. Differential = Operate Point - Release Point
2. Minimum Release Point for AD8xx-xx to AD9xx-xx = 5 Oe.
3. Output current must be limited by a series resistor. Exceeding absolute maximum continuous output current ratings will result in damage to the part.
4. Thermal power dissipation for the packages used by NVE is 240°C/Watt for the SOIC8 package, and 320°C/Watt for the MSOP8 and TDFN6 packages. See the Figure on Ambient Temperature vs. Supply Voltage for derating information. Heat sinking the parts by attaching them to a PCB improves temperature performance.
5. There is no maximum magnetic field that will cause damage to the device.
6. If V<sub>CC</sub> > 6.6V, V<sub>REG</sub> = 5.8V. If V<sub>CC</sub> < 6.6V, V<sub>REG</sub> = V<sub>CC</sub> - 0.9V.

**ADH0xx-xx**

**Features:**

- Precision Low Field Magnetic Operate Point
- Excellent Temperature and Voltage Performance
- Digital Output
- Frequency Response 0 to 250kHz
- Small, Low-Profile Surface Mount Packages

**Applications:**

- Low Field Digital Position Sensing
- Pneumatic Cylinder Position Sensing
- Speed Sensing

**Description:**

The NVE ADH0xx Series GMR Switch uses NVE’s high sensitivity, high temperature GMR material to provide a very low magnetic field operate point. It offers the same precision operate points over all temperature and input voltage conditions as our other GMR Switch products. It is available in standard form as the NVE ADH025-00 with a magnetic trigger field of 10 Gauss, a current sinking output, and a cross axis configuration. Custom versions with trigger fields ranging from 6 to 40 Gauss, and different output options and sensitivity directions could be manufactured for specific customer requirements; please contact NVE for details.

Note: Functional Block Diagram for the NVE ADH0xx-xx Series sensors is the same as for the NVE AD0xx-xx sensors.

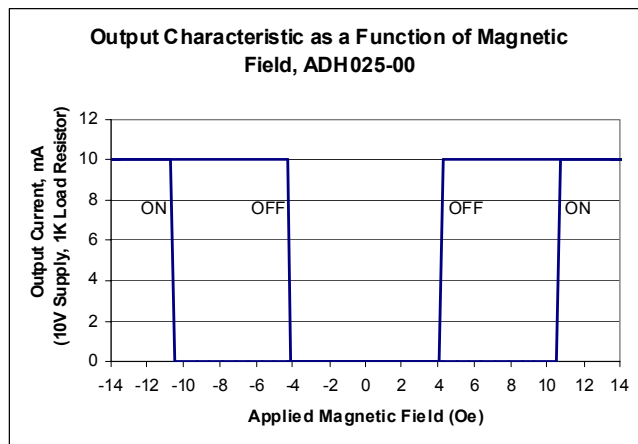

## Magnetic Characteristics, NVE ADH025-00:

Typical Operate Point	Minimum Operate Point	Maximum Operate Point	Minimum Differential <sup>1</sup>	Maximum Differential <sup>1</sup>	Test Conditions
10 Oe	8 Oe	12 Oe	3.5 Oe	10 Oe	V <sub>CC</sub> =12V, 25°C

## Electrical Specifications, NVE ADH0xx-xx:

Parameter	Symbol	Min	Max	Units	Test Condition
Supply Voltage <sup>4</sup>	V <sub>CC</sub>	4.5	30	V	Operating
Supply Current, Single Output	I <sub>CC</sub>	3.0	6.0	mA	Output Off, V <sub>CC</sub> =12V
Current Sinking Output <sup>3</sup>	I <sub>O</sub>	0	20	mA <sup>3</sup>	Operating
Output Leakage Current	I <sub>LEAK</sub>		10	μA	Output Off, V <sub>CC</sub> =12V
Sinking Output Saturation Voltage	V <sub>OL</sub>		0.4	V	Output On, I <sub>OL</sub> =20mA

## Absolute Maximum Ratings:

Parameter	Symbol	Min	Max	Units
Supply Voltage	V <sub>CC</sub>		33	V
Reverse Battery Voltage	V <sub>RBP</sub>		-33	V
Current Sinking Output Off Voltage			33	V
Current Sourcing Output Off Voltage			0	V
Current Sinking Reverse Output Voltage			-0.5	V
Current Sourcing Reverse Output Voltage			-0.5	V
Output Current	I <sub>O</sub>		24	mA
Operating Temperature Range <sup>4</sup>	T <sub>A</sub>	-40	125	°C
Storage Temperature Range	T <sub>S</sub>	-65	150	°C
Magnetic Field <sup>5</sup>	H		None	Oe

### Notes:

- Differential = Operate Point - Release Point
- Minimum Release Point for ADH0xx-xx = 2.0 Oe.
- Output current must be limited by a series resistor. Exceeding absolute maximum continuous output current ratings will result in damage to the part. See the figure in the GMR Switch Product Selection Guide for an output current derating curve.
- Thermal power dissipation for the packages used by NVE is 240°C/Watt for the SOIC8 package, and 320°C/Watt for the MSOP8 and TDFN6 packages. See the Figure on Ambient Temperature vs. Supply Voltage for derating information. Heat sinking the parts by attaching them to a PCB improves temperature performance.
- There is no maximum magnetic field that will cause damage to the device.



## GT Sensors™

### Precision Gear Tooth and Encoder Sensors

NVE's GT Sensor™ products are based on a Low Hysteresis GMR sensor material and are designed for use in industrial speed applications where magnetic detection of gear teeth and magnetic encoder wheels is required.

GT Sensors with both analog and digital outputs are available. The analog parts feature the large signal and robust characteristics which NVE's GMR materials are known for (NVE's GMR sensors are not damaged by extremely large magnetic fields). The sensor elements themselves are designed to provide usable output with even the smallest gear teeth. Single and double output versions are available; the second output is phase shifted with respect to the first, to provide quadrature for determining direction.

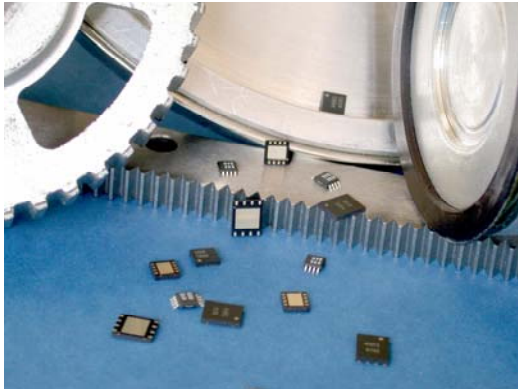

The digital sensors take advantage of the high performance characteristics of GMR sensors to provide a 50% duty cycle output with a wide tolerance in airgap and temperature variations.

GT Sensors are available in low-profile MSOP8, TDFN SO8, and TDFN6 packages, in order to fit into the tightest possible spaces. An evaluation kit is available, containing a selection of sensors, magnets, and PCBs, so that the user can test the parts in their application

## **ABL Sensors**

### **Single/Double Bridge Gear Tooth And Encoder Sensors**

#### ***Features:***

- Large Airgap
- Direct Analog Output
- DC (Zero Speed) Operation
- Sine / Cosine Outputs
- Precise Spacing and Phase Shifting Between Sensor Elements
- Excellent Temperature and Voltage Performance
- Small, Low-Profile Surface Mount Packages

#### ***Applications:***

- Linear and Angular Speed Sensing
- Linear and Angular Position Sensing
- Direction Detection

#### ***Description:***

The ABL-Series GT Sensors are differential sensor elements that provide an analog sinusoidal output signal when used with a bias magnet and gear tooth or a magnetic encoder. These chips use NVE's proprietary GMR sensor elements featuring an extremely large output signal from the raw sensor element, which is stable over the rated temperature and voltage range. As a result, ABL-Series GT Sensors feature excellent airgap performance and an extremely stable operating envelope as well as the robust reliability characteristics that NVE sensors are known for.

Three different standard spacings are available for use with fine and coarse pitch encoders and gear teeth. Both single bridge and double bridge configurations are also available. Double bridges are used to generate sine/cosine outputs. In addition to the standard spacings, NVE can provide custom spacings and multiple sensor elements tailored to the individual customer's application for a nominal design and tooling charge. Contact NVE for further details.

For digital output applications, these sensors can be used with NVE's DD001-12 signal processing IC which converts their output into a 50% duty cycle modulated current signal. This IC allows placement of the ABL sensor in a very small housing with wires running from the sensor to the signal processing IC in a remote location. Thus ABL-Series sensors can be used in M8 and smaller housings.

### Specifications:

Parameter	Min	Typ	Max	Unit
Single Bridge Resistance at 25°C	4K	5K	7K	Ohms
Input Voltage	<1 <sup>1</sup>		30 <sup>1</sup>	Volts
Operating Temperature Range	-50		+150	°C
Offset Voltage	-4		+4	mV/V
Linear Range	±5		±100	Oe
Linearity of Output	98			% <sup>2</sup>
Hysteresis			2	% <sup>2</sup>
Saturation of GMR Sensor Elements	-180		+180	Oe <sup>3</sup>
Single Resistor Sensitivity		.04		%ΔR/Oe <sup>4</sup>
Max Output		80		mV/V
Temperature Coefficient of Resistance		+0.11		%/°C
ESD		400		V <sup>5</sup>
Storage Temperature Range	-65		+170	°C

### Notes:

1. ABL-Series sensors have a purely ratiometric output. They will operate with input voltages of 0.1 V or lower. The output signal will scale proportionally with the input voltage. Maximum voltage will be limited by the power dissipation allowable in the package and user installation. See the package section for more details.
2. Linearity and Hysteresis measured across linear operating range, unipolar operation.
3. Application of a magnetic field in excess of this value will saturate the GMR sensor elements and no further output will be obtained. No damage occurs to the sensor elements when saturated. *NVE GMR sensors will not be damaged by any large magnetic field.*
4. Percent change in resistance with application of 1 Oersted of magnetic field; corresponds to an 8% change in resistance with 200 Oersteds of applied magnetic field (1 Oersted = 1 Gauss in air, or 0.1 milliTesla).
5. Pin-to-pin voltage, Human Body Model for ESD.

**IC Drawings:**

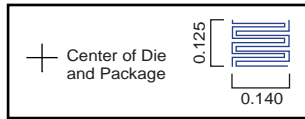

ABL004

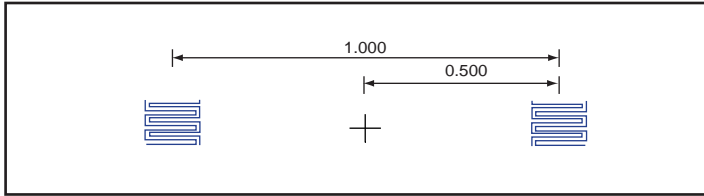

ABL005

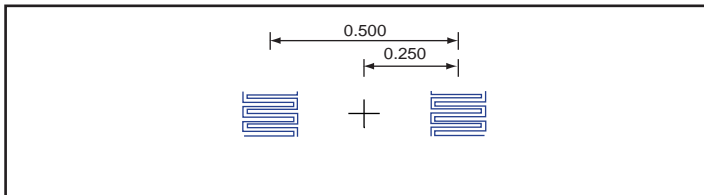

ABL014

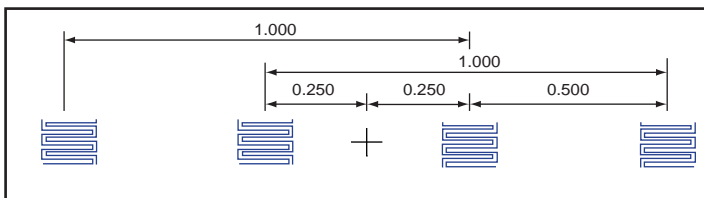

ABL015

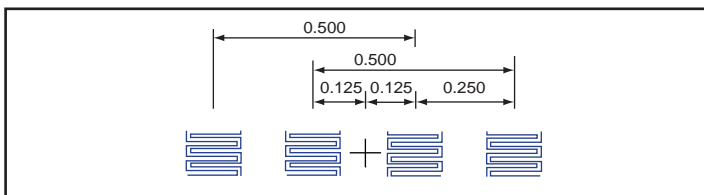

- All dimensions in mm
  - All resistors are 5kΩ
  - Sensor elements are located symmetrically about the center of the IC.
- Note: ABL006 ABL016 Sensor Element Size and Spacing Not Shown**

**Schematics:**

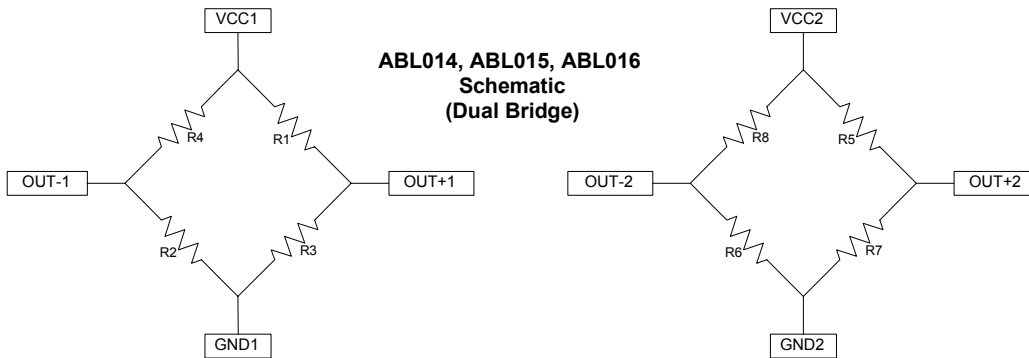
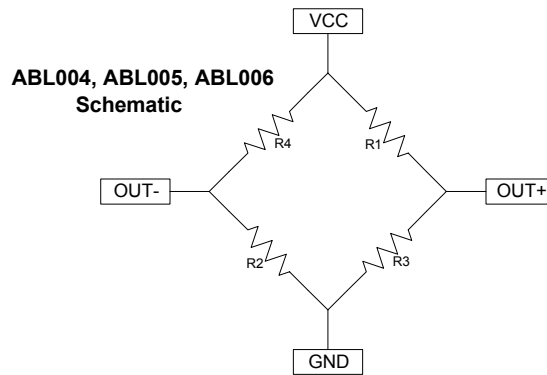

**Part Numbers and Configurations:**

Part Number	Single or Dual Bridge	Element Spacing (Microns)	Phase Shift Between Bridges (Microns)	Package Marking
ABL004-00	Single	1000	NA	FDB
ABL005-00	Single	500	NA	FDC
ABL006-00	Single	300	NA	FDL
ABL014-00	Dual	1000	500	FDD
ABL015-00	Dual	500	250	FDL
ABL016-00	Dual	300	150	FDM
ABL004-10	Single	1000	NA	FDG
ABL005-10	Single	500	NA	FDH
ABL006-10	Single	300	NA	FDN
ABL014-10	Dual	1000	500	FDJ
ABL015-10	Dual	500	250	FDK
ABL016-10	Dual	300	150	FDP

**Packages:**

The ABL-Series parts are available in MSOP8 and TDFN6 packages. Please see the package drawing section in the Appendix for dimensions. Please note that for dual differential sensors in the TDFN package the power and ground connections for both bridges are common.

**Pin Configuration:**

**MSOP8 Package**

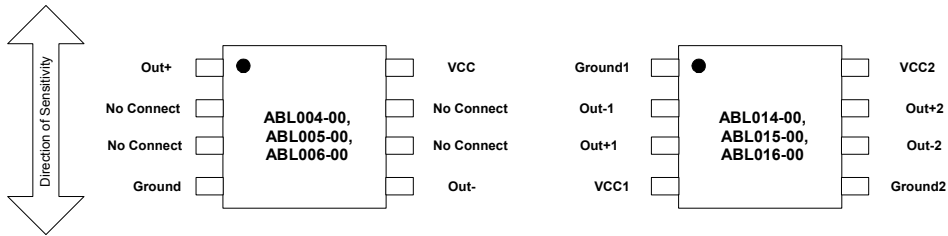

**TDFN6 Package**

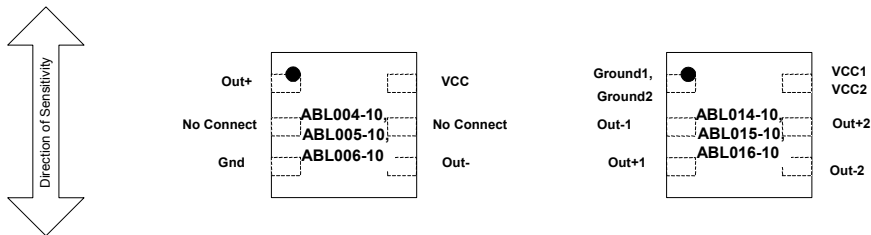

## AKL Sensors

### Digital Output Gear Tooth And Encoder Sensors

#### **Features:**

- Large Airgap
- 50% Duty Cycle
- DC (Zero Speed) Operation
- Precise Spacing Between Sensor Elements
- Excellent Temperature and Voltage Performance
- Small, Low-Profile Surface Mount Package

#### **Applications:**

- Anti-lock Brake System Sensors
- Transmission Speed Sensors
- Industrial Linear and Angular Speed Sensing
- Linear and Angular Position Sensing

#### **Description:**

NVE offers these products specifically for use as sensors for gear tooth wheels or magnetic encoders with a digital output signal. The pulse output from the sensor corresponds with the gear teeth passing in front of it. When a gear tooth or magnetic pole is in front of the sensor, the sensor's output goes high; when the gear tooth or magnetic pole moves away, the output returns to low. This repeats at every tooth/pole resulting in a pulse train output that provides speed information from the gear or encoder. Three part numbers are currently available: the AKL001-12 is designed for gear teeth or encoders with a pitch of 2.5 to 6 mm, the AKL002-12 for a pitch of 1 to 2.5 mm, and the AKL003-12 for a pitch of 0.6 to 1.5 mm.

In order to minimize the number of wires leading to the sensor, the part is configured as a two-wire device. The two output states are indicated with a change of current through the part. Therefore, when the part is in the digital low state, current is about 3 mA. When the part is in the digital high state, the current increases to about 10 mA. If necessary, the two-wire output of the AKL-Series parts can be easily converted to a three-wire current sinking output with the circuit shown in the GT Sensor applications section.

The parts are rated for the full automotive and industrial temperature range, -40°C to +150°C. They feature reverse battery protection and have an operational voltage range of 4.5V to 36V. They operate from DC to 10 kHz. The parts are available in low-profile, surface mount TDFN SO8 packages.

**Specifications:**

Parameter	Min	Typ	Max	Unit
Input Voltage	4.5		36	Volts <sup>1</sup>
Supply Current in Off State (Input Voltage=12V)	3.2	4.0	4.8	mA <sup>2</sup>
Supply Current in On State (Input Voltage=12V)	7.0	8.0	9.0	mA <sup>2</sup>
Output Duty Cycle	40	50	60	%
Operating Temperature Range	-40		+150	°C
AKL001-12 Airgap, Over Full Temperature and Voltage Range <sup>3</sup>	1.0		3.5	mm
AKL002-12 Airgap, Over Full Temperature and Voltage Range <sup>3</sup>	1.0		2.5	mm
AKL003-12 Airgap, Over Full Temperature and Voltage Range <sup>3</sup>	1.0		2.0	mm
Frequency of Operation	0		10K	Hz
ESD		2000		V <sup>3</sup>

Absolute Maximum Ratings	
Parameter	Limit
Supply Voltage	45V
Reverse Battery Voltage	-60V
Continuous Output Current	16mA
Junction Temperature Range	-40°C to +170°C
Storage Temperature Range	-65°C to +170°C

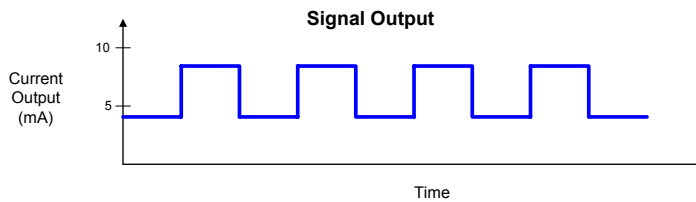

**Notes:**

1. The supply voltage must appear across the power and ground terminals of the part. Any additional voltage drop due to the presence of a series resistor is not included in this specification.
2. Supply currents can be factory programmed to different levels, for example 3 mA and 6 mA, or 7 mA and 14 mA; contact NVE for details.
3. Pin-to-pin voltage, Human Body Model for ESD
4. Airgap measured with standard ferrous gear tooth; contact NVE for details.

**IC Drawings:**

The AKL-Series products use the ABL sensor elements described earlier in this section. The AKL001-12 part uses the ABL004 sensor element, the AKL002-12 uses the ABL005 sensor element, and the AKL003-12 uses the ABL006 sensor element. Please see the IC drawings in the ABL-Series section for more information.

**Part Numbers and Configurations:**

Part Number	Single or Dual Bridge	Element Spacing (Microns)	Marking
AKL001-12	Single	1000	Part Number
AKL002-12	Single	500	Part Number
AKL003-12	Single	300	Part Number

**Schematic:**

A block diagram of the AKL-Series parts is shown below:

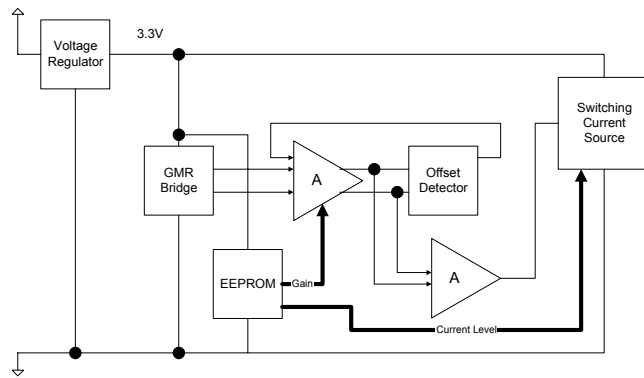

**Packages:**

The AKL-Series parts are available in the TDFN8 SO8 package. Please see the package drawing section in the Appendix for dimensions.

**Pin Configuration:**

**TDFN8-SO8 Package**

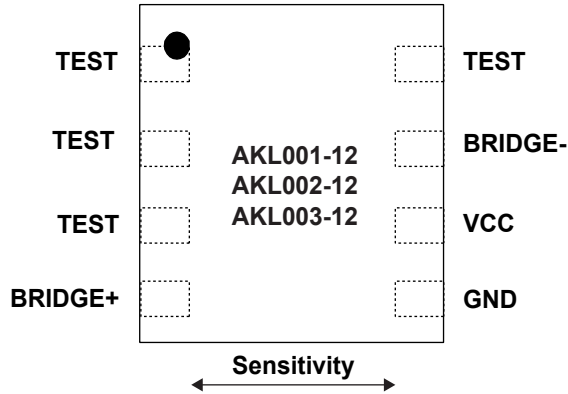

Note: Bridge + and Bridge - are provided for analysis purposes only. NVE does not recommend connecting these pins in a production product for ESD and loading reasons. Also, all pins labeled "Test" must be floating, *i.e.*, not connected to each other or any other circuit node.

**Circuit Board Sensor Products****AG21x-07 Cylinder Position Sensors  
PCB Assemblies for Pneumatic Cylinder Applications****Features:**

- Precision Magnetic Operate Point
- Three-Wire Current Source or Current Sink Output
- Wide Operating Temperature Range
- Short Circuit, Transient, and ESD Protected
- Conforms to EN 60947-5-2 Standards for Switchgear

**Applications:**

- Pneumatic Cylinder Position Sensing
- General Magnet Position Sensing

**Description:**

The AG211-07 and AG212-07 PCB assemblies are small, sensitive magnetic sensors for use in pneumatic cylinder position sensing and other position sensing applications. They are designed to be potted or injection molded by the customer to make a complete magnetic sensor assembly with a cable attached and enclosed in a plastic housing. The PCB assemblies include an NVE AD9xx magnetic sensor, a DB001 signal processing IC, plus surrounding signal processing and filtering components. These parts provide a precise, temperature stable magnetic operate point and will source up to 200 mA of output current. They also feature reverse battery protection and short circuit protection as well as immunity to transients as specified in US and European standards such as EN60947-5-2.

The assemblies have a yellow LED to indicate the presence of the magnetic field, and are sized to fit into small package housings. Output from the parts are open-collector PNP transistors in current-sourcing configuration. The customer is required to limit the output current to the desirable level, from 5 mA to 200 mA, with an external load resistor.

## AG211-07 Photo



Top View



Bottom View

## AG212-07 Photo



Top View



Bottom View

General Electrical Characteristics				
Parameter	Min	Typical	Max	Unit
Input Voltage Range	4.5		30	V
Temperature Range <sup>2</sup>	-20		85	°C
Magnetic Operate Point <sup>1</sup>	21	28	34	Oe
Magnetic Release Point <sup>1</sup>	5		14	Oe
Reverse Battery Protection			-30	V
LED		Yellow		
V <sub>CC</sub> - V <sub>OH</sub> (Maximum Output Voltage Drop Across Part)			2	V
Output Current	5		200	mA
Supply Current	2.5		4.5	mA
Short Circuit Protection Limit			350	mA

### Notes:

1. See AD924-00 data in GMR Switch section of this catalog.
2. These parts are assembled with high temperature solder; overmolding at temperatures up to 210°C for 10 seconds is approved.

**PCB Assembly Dimensions:**

Part Number	Length, inches (mm)	Width, inches (mm)	Height, inches (mm)
AG911-07	0.755 (19.2)	0.165 (4.2)	0.100 (2.55)
AG912-07	0.540 (13.7)	0.115 (2.9)	0.085 (2.16)

**Functional Block Diagram for AG211 and AG212:**

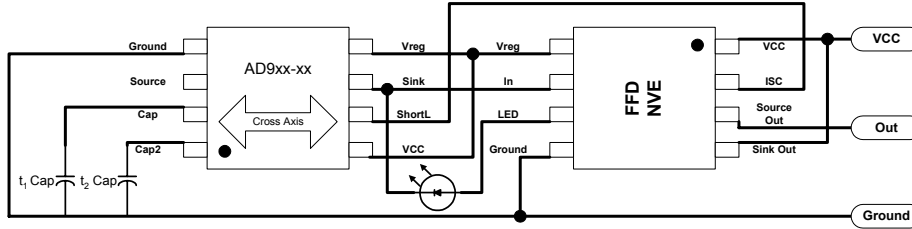

**Wiring Diagram:**

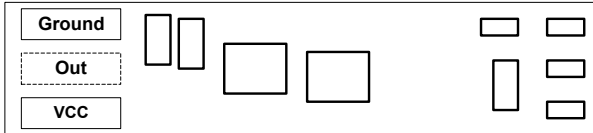

Note: the dotted line pad is on the backside of the PCB.

## AG-Series Currency Detection Sensors Sensor Arrays for Currency / Magnetic Media Detection

### Features:

- Arrays of Sensor Elements for Broad Area Coverage
- No Contact with Media Required
- Capable of Detecting Very Low Magnetic Fields

### Applications:

- Currency Detection and Validation
- Other Magnetic Media Applications (Checks, Credit Cards, etc.)
- General Area Sensing for Low Magnetic Fields

### Description:

These products are custom-built PCB assemblies for customer specific applications. They typically contain 20 to 60 analog GMR sensor elements, most often the AA002, AAH002, or AAL002 sensors. These sensors are mounted on a PCB, most often using Chip-On-Board (COB) assembly techniques, so that the sensor elements can be placed very close together. In addition, a coil on the PCB is provided on many of these designs, so that a current can be fed through the coil to provide a magnetic bias field at the sensors.

In a typical currency detection application, this PCB assembly is positioned approximately 1 mm from the currency path. The bank note is typically magnetized with a permanent magnet before it reaches the sensor array. The residual magnetization in the magnetic ink or stripe of the currency is detected by the sensor array. This information is then analyzed to determine if the currency is genuine. See the figure below:

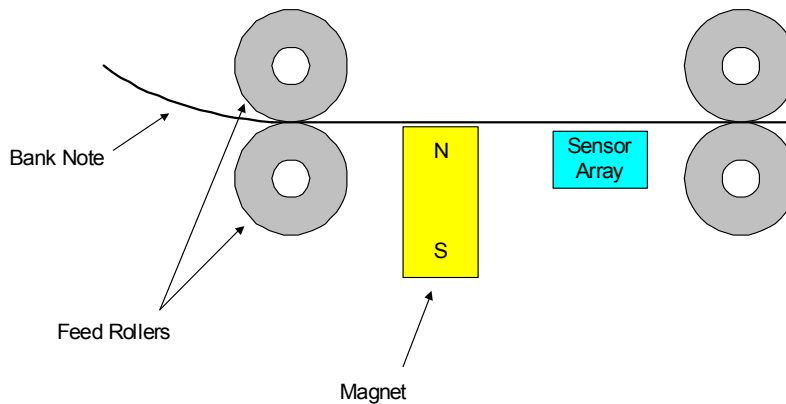



## Peripheral Integrated Circuits

In addition to GMR Sensor products, NVE has begun designing and manufacturing accessory products for our sensors. These products are designed to be used with NVE's sensors, or in some cases as stand-alone parts, to provide higher level signal processing capabilities coupled with the robust performance characteristics that NVE products are known for.

**DB-Series Power Switch ICs** – In many industrial control applications, a digital current output of up to 200 mA is required. NVE's DB-Series parts are designed to meet these requirements. They feature transient protection to meet rigid EMC and ESD standards, thermal shutdown for temperature protection, reverse battery protection, a regulated voltage output, an on-chip LED driver, and short circuit protection of the current drive output transistor. The DB001-00 is designed specifically to work together with NVE's AD9xx-00 short circuit protected GMR switch to create a very small IC combination suitable for use in miniature sensor assemblies. The DB002-02 is designed to take a generic digital input from any source, including inductive and photo sensors, and provide the digital current output.

**DC Series Voltage Regulator ICs** – These ICs are designed for use in high voltage, low current applications. They provide a wide input voltage range, up to 60V, and are available in 3.3V and 5.0V outputs. They feature reverse battery protection and excellent immunity to transients and noise allowing for the reduction or elimination of filtering devices at the PCB level. They are available in the TDFN6 package, which features a small PCB footprint (2.5 mm x 2.5 mm) and an exposed lead frame on the back for heat sinking to the PCB. DC series voltage regulators meet 42V automotive standards.

**DD-Series Signal Processing IC for Analog GT Sensors** – The DD001-12 is designed to be interfaced with an NVE ABL-Series GT Sensor to provide a digital output signal with excellent stability characteristics. It can be located away from the sensor so that the ABL package (MSOP8 or TDFN6) can be placed in a small remote housing, resulting in the absolute minimum size sensor package. The DD001-12 can also be used with other sensing devices which feature a sinusoidal output, to provide the same stable current modulated signal that it provides for NVE's ABL-Series GT Sensors.

## DB001-00 Series Power Switch IC

### Features:

- Designed to Work with AD9xx
- High Current Output
- Short Circuit, Reverse Battery, and Transient Protection
- LED Driver
- Excellent Temperature and Voltage Performance
- Small, Low-Profile Surface Mount Package

### Applications:

- Output Driver for Sensor Assemblies
- Usable with Magnetic, Inductive, and Photo Sensors

### Description:

The DB001-00 signal processing IC is designed to take the digital input signal from NVE's AD9xx GMR Switch and provide a high current switched output corresponding with the sensor input. The part functions as the "front end" of a complete sensor assembly and includes protection against short circuits and high voltage transients from capacitive and inductive loads. The parts also feature thermal shutdown circuitry and reverse battery protection. It provides a regulated output voltage for the sensor and other components in the assembly and an LED driver to indicate an "ON" condition.

Together, the AD9xx GMR Switch and the DB001-00 signal processing IC form the bulk of the signal processing required for pneumatic cylinder position sensing electronics. Using these two ICs, the end user only requires a few capacitors and an LED in order to implement the complete sensor assembly circuit. In addition, both the AD9xx part and the DB001-00 part come in MSOP8 packages, so that the customer can implement the complete design on an extremely small PCB.

If ultra-miniaturization is desired, the DB001 part can be obtained in die form for COB (Chip On Board) or flip-chip assembly.

### Part Numbers and Configurations:

Part Number	Input	Die Size (mm)	Package	Marking
DB001-00	Current Sinking from AD9xx-00	1.48 x 2.25	MSOP8	FFD
DB001-01	Current Sinking from AD9xx-00	1.48 x 2.25	Raw IC	30284D

**Schematic:**

A block representation of the DB001-00 series part is shown below:

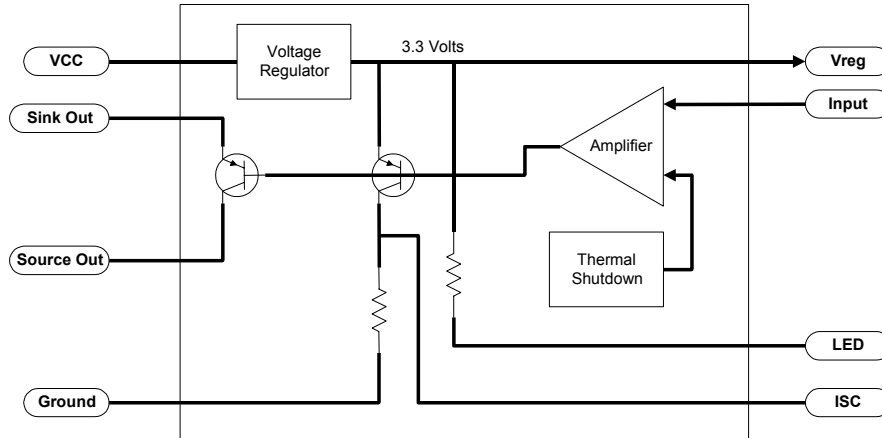

**Packages:**

Please see the package drawing section in the Appendix for dimensions of the MSOP8 package.

**Pin Configuration:**

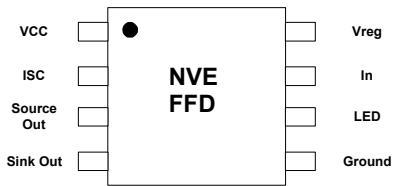

## Application Circuits:

DB001-00 in Current Sourcing Output Configuration:

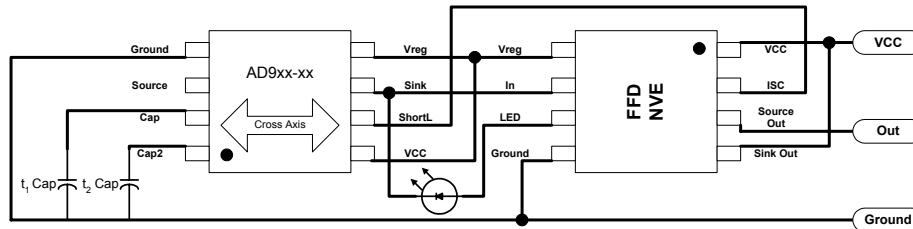

**Note:** For current-sinking applications, connect “Source Out” to Ground; use “Sink Out” pin as output.

### Electrical characteristics (-40°C to +125°C, unless otherwise noted)

Parameter	Min	Typ	Max	Units
Input Voltage	4.5		30	V
Vreg Voltage	3.0	3.3	3.6	V
Vreg Output Current			10	mA
Switched Output Current			200	mA
Capacitive Load			100	nF
Off State Output Leakage Current			300	μA
Bias Current (output off)		1.0		mA
LED Drive Current		3		mA
Thermal Shutdown Temperature		200		°C
Sinking Input Current Required		100		μA
Output Transistor Saturation Voltage	0.5	1.1	1.5	V
Output Short Circuit Current	0.5	0.84	1.0	A

Absolute maximum ratings*	
Parameter	Limit
Input Voltage	36 V
Reverse Battery Protection	-36 V
Output Current	250 mA
Junction Temperature Range, T <sub>J</sub>	-40°C to +170°C
Storage Temperature Range	-65 °C to +170°C

\*Stresses beyond those listed under “Absolute maximum ratings” may cause permanent damage to the device. These are stress ratings only and functional operation of the device at these or any other conditions beyond those indicated under “Electrical characteristics” is not implied.

### Notes:

1. This part has reverse battery protection to -36V
2. Due to package size, MSOP8 package contains 3-letter code to designate part type.

## DB002-02 Series Power Switch IC

### Features:

- Designed to Work with Magnetic, Inductive, or Photo Sensors
- Up to 300 mA Continuous Current Output
- Short Circuit, Reverse Battery, Transient and Thermal Protection
- On-Chip LED Driver
- Excellent Temperature and Voltage Performance
- Available in SOIC8 Package or in Die Form

### Applications:

- Output Driver for Sensor Assemblies
- Usable with Magnetic, Inductive, and Photo Sensors

### Description:

The DB002 series power switch IC is designed to take a digital input from a sensor element and provide a high current switched output corresponding with the sensor input. The part functions as the “front end” of a complete sensor assembly and includes protection against short circuits and high voltage transients from capacitive and inductive loads. The part also features thermal shutdown circuitry and reverse battery protection. It provides a regulated output voltage for the sensor and other components in the assembly and an LED driver to indicate an “ON” condition.

The DB002 is available in the SOIC8 package (p/n DB002-02), as well as in die form (p/n DB002-01). It is designed to work with NVE’s AD1xx GMR Switch products, or any other current sourcing or CMOS/TTL digital output sensor element such as an inductive sensor or a photo sensor.

### Part Numbers and Configurations:

Part Number	Input	Die Size (mm)	Package	Marking
DB002-01	Any Current Sourcing or CMOS/TTL Compatible Digital Output Device	1.89 x 2.85	Die	30304H (Chip ID Number)
DB002-02	Any Current Sourcing or CMOS/TTL Compatible Digital Output Device	1.89 x 2.85	SOIC8	DB002-02

**Functional Block Diagram and Pinout:**

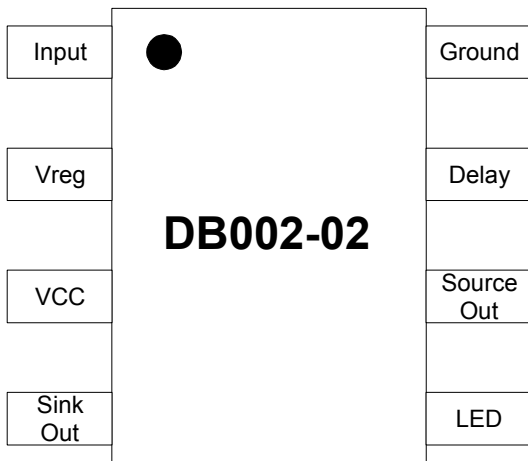
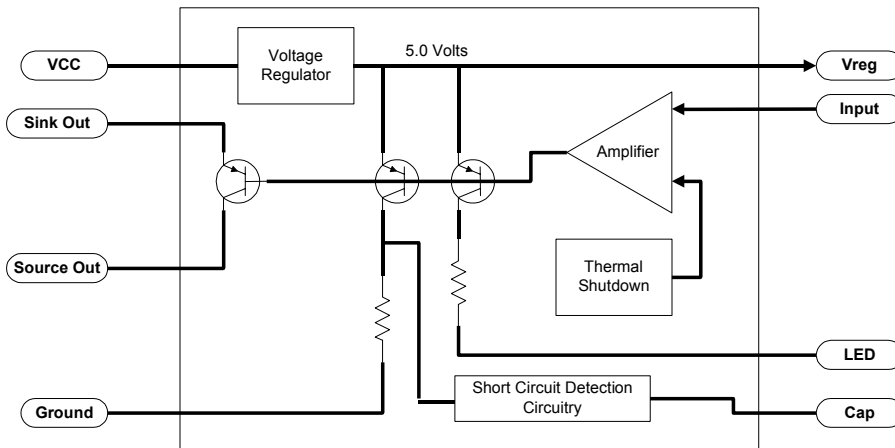

**Packages:**

Please see the package drawing section in the Appendix for dimensions of the SOIC8 package.

## Example Application Circuit:

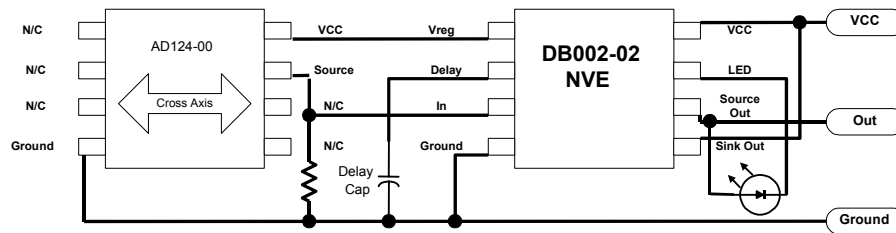

### Notes on Operation:

1. A capacitor of at least 1nF value must be placed between the Delay pin and ground on the IC.
2. NVE recommends a bypass capacitor between VCC and Ground, 10nF or larger
3. In noisy environments a capacitor may be used on Vreg if necessary, up to 100nF.

### Electrical characteristics (-40°C to +125°C, unless otherwise noted)

Parameter	Min	Typ	Max	Units
Input Voltage	6.2		30	V
Vreg Voltage	4.5	5.0	5.5	V
Vreg Output Current			10	mA
Switched Output Current			300	mA
Capacitive Load			100	nF
Off State Output Leakage Current			300	μA
Bias Current (output off)		1.4		mA
LED Drive Current		3		mA
Thermal Shutdown Temperature		200		°C
Sourcing Input Current or CMOS/TTL Drive Current Required (DB002-02)		5		μA
Turn-On Voltage at Input Terminal			3.0	V
Turn-Off Voltage at Input Terminal	2.0			V
On/Off Hysteresis		0.25		V
Output Transistor Saturation Voltage	0.5	1.1	1.5	V
Short Circuit Protection Turn-On Current	400		650	mA
Output Short Circuit Current	0.5	0.84	1.0	A

Absolute maximum ratings*	
Parameter	Limit
Input Voltage	36V
Reverse Battery Protection	-36V
Output Current	350mA
Junction Temperature Range, T <sub>J</sub>	-40°C to +170°C
Storage Temperature Range	-65 °C to +170°C

\*Stresses beyond those listed under “Absolute maximum ratings” may cause permanent damage to the device. These are stress ratings only, and functional operation of the device at these or any other conditions beyond those indicated under “Electrical characteristics” is not implied.

## DC-Series Voltage Regulators High Voltage, Low Power Voltage Regulators

### Features:

- Input Voltage to 36VDC (Max Rating 45VDC)
- 5.0V and 3.3V Regulated Output
- Reverse Battery Protection
- Excellent Immunity to Transients and ESD
- High Temperature Operation
- Small, Low-Profile Surface Mount Package

### Applications:

- Industrial Sensors and Controls
- Automotive Sensors and Controls

### Description:

The DC series voltage regulator ICs are designed for use in harsh, noisy environments where immunity to large voltage transients and acceptance of high input voltages are required. These regulators protect the sensitive electronic components downstream, while providing a stable regulated supply voltage. They are rated for high temperature operation, up to +170°C. The low-profile small footprint package features an exposed die attach pad, for direct heat sinking to the circuit board.

### Specifications

#### Electrical characteristics (-40°C to +175°C, unless otherwise noted)

Parameter	Min	Typ	Max	Units
Input Voltage (DC001-10)	4.5		36	Volts
Output Voltage (DC001-10)	3.0	3.3	3.6	Volts
Input Voltage (DC002-10)	6.2		36	Volts
Output Voltage (DC002-10)	4.5	5.0	5.5	Volts
Output Current			20	Milliamps
Bias Current at Zero Output Current			900	Microamps

Absolute maximum ratings*	
Parameter	Limit
Input Voltage	45V
Reverse Battery Voltage	-60V
Output Current	25mA
Junction Temperature Range, T <sub>J</sub>	-40°C to +170°C
Storage Temperature Range	-65 °C to +170°C

\*Stresses beyond those listed under “Absolute maximum ratings” may cause permanent damage to the device. These are stress ratings only, and functional operation of the device at these or any other conditions beyond those indicated under “Electrical characteristics” is not implied.

**Notes:**

1. Power dissipation rating for TDFN6 package in free air is 320°C/Watt. Soldering the package to a PCB, including the die attach paddle, improves temperature performance substantially. The input voltage and output current are limited by thermal power dissipation at the package.
2. Due to package size, TDFN6 package has a three-letter code to designate part type.

**Package:**

Please see the package drawing section in the Appendix for dimensions of the TDFN6 package.

**Pin Configuration**

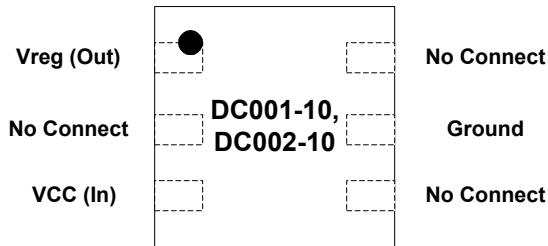

**Note:** The die attach pad is exposed on the back of this package. NVE recommends that it be connected to the ground pin and the PCB for improved temperature performance.

**DD-Series Signal Processing ICs  
For use with ABL-Series Sensors****Features:**

- Converts Analog Sensor to Digital Operation
- Two-Wire Output
- 50% Duty Cycle
- DC (Zero Speed) Operation
- Excellent Temperature and Voltage Performance
- Small, Low-Profile Surface Mount Package

**Applications:**

- Linear and Angular Speed Sensing
- Linear and Angular Position Sensing
- Direction Detection

**Description:**

The DD-Series signal processing IC is designed to take an analog, sinusoidal input signal such as that provided by NVE's ABL-Series sensors and convert it to a two wire, current modulated digital output. Inputs as small as 2 mV peak-to-peak can be provided to the IC, along with large signal offsets. The DD001-12 part will provide a 50% duty cycle digital output signal.

The DD001-12 part contains a voltage regulator circuit, programmable amplifier, offset detection and correction circuitry, and an EEPROM for setting gain and current levels. The voltage regulator output (3.3V) is used to power the external sensor element, which should be connected between VREG and VGND. Nominal current levels for the current modulated output are 3 mA and 10 mA. These can be factory programmed to different levels for specific customer requirements.

Using the DD-Series signal processing IC allows the user to put the sensor element, which can very small in a remote location, and pipe the signals from the sensor to the DD001-12 for digitizing purposes. In addition, if two phase shifted sensor outputs are available (such as with the ABL014-00, ABL015-00, and ABL015-00 sensors), two DD001-12 parts can be used to provide two phase shifted digital signals, for the purpose of detecting the direction of the gear tooth or encoder wheel.

The two-wire output of the DD001-12 can be easily converted to a three-wire current-sinking output with the circuit shown in the GT Sensor applications section.

**Specifications:**

Parameter	Min	Typ	Max	Unit
Input Voltage	4.5		36	Volts <sup>1</sup>
Input Voltage Signal	2		200	mV <sup>2</sup>
Input Current			10	μA
Supply Current – Off (Input Voltage=12V)	2.2	3.0	3.8	mA <sup>3</sup>
Supply Current – On (Input Voltage=12V)	7.0	8.0	9.0	mA <sup>3</sup>
Output Duty Cycle	40	50	60	%
Regulated Voltage Output	3.0	3.3	3.6	Volts
Current Supplied by Regulated Voltage Output			10	mA
Operating Temperature Range	-40		+150	°C
Frequency of Operation	0		10k	Hz
ESD		2000		V <sup>4</sup>

Absolute Maximum Ratings	
Parameter	Limit
Supply Voltage	45V
Reverse Battery Voltage	-60V
Output Current	16mA
Junction Temperature Range	-40°C to +170°C
Storage Temperature Range	-65°C to +170°C

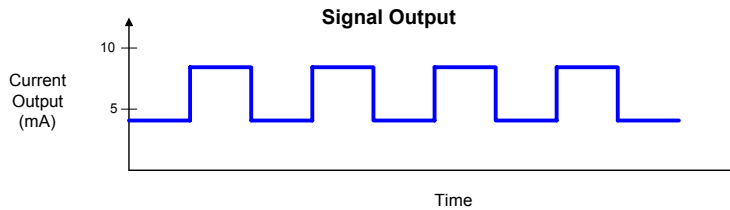

**Notes:**

1. The supply voltage must appear across the power and ground terminals of the part. Any additional voltage drop due to the presence of a series resistor is not included in this specification.
2. Input signal range can be adjusted by programming the amplifier gain to a specific value; contact NVE for details.
3. Supply currents can be factory programmed to different levels, for example 3 mA and 6 mA, or 7 mA and 14 mA; contact NVE for details.
4. Pin-to-pin voltage, Human Body Model for ESD.

**Schematic:**

A block representation of the DD-Series parts is shown below:

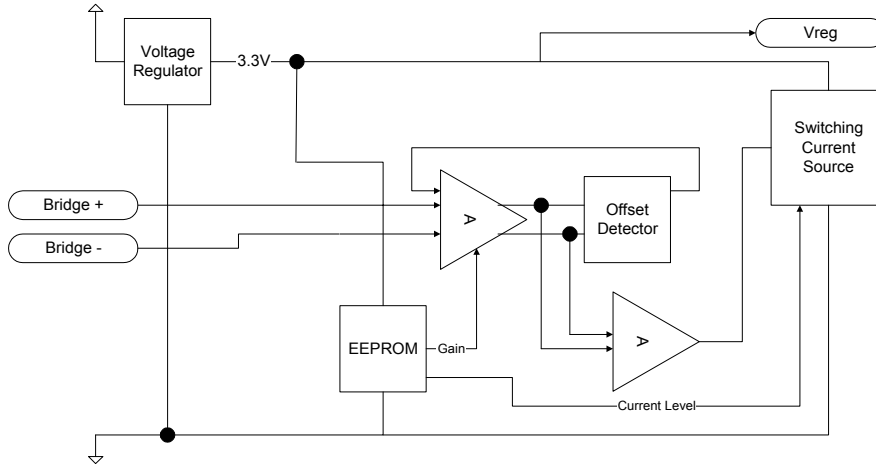

**Packages:**

The DD-Series parts are available in the TDFN SO8 package. Please see the package drawing section in this catalog for dimensions.

**Pin Configuration:**

**TDFN-SO8 Package**

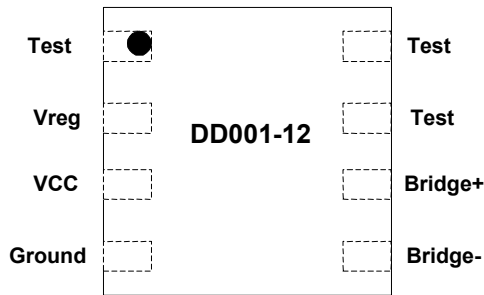

Note: Bridge + and Bridge - should be connected only to the sensor element outputs for ESD and loading reasons. Vreg can supply up to 10 mA at 3.3V (330Ω load). Also, all pins labeled “Test” must be floating, *i.e.*, not connected to each other or any other circuit node.

**Evaluation Kits**

In order for our customers to evaluate GMR sensors in their application NVE makes available several evaluation kits, at nominal cost, so that customers can try the actual parts in their application. These kits are described below:

***AG001-01 - Analog Sensor Evaluation Kit***

This kit features several types of NVE's AA and AB-Series parts, a selection of permanent magnets for activation or bias purposes, and circuit boards to mount the parts for testing purposes.

***AG003-01 - Current Sensor Evaluation Kit***

This kit features a specially designed circuit board with traces running under the sensor elements. The customer can try different current levels to see the output from the sensor.

***AG910-07, AG911-07 - GMR Switch Evaluation Kits***

These kits include several GMR Switch parts with different magnetic operate points and different output options such as current sink and current source. In addition, magnets and circuit boards for mounting the parts in the application are included. In the AG910-07 kit, a socket for easy testing of the MSOP-8L package is also included.

***AG920-07 - GT Sensor Evaluation Kit***

NVE's newest evaluation kit includes analog and digital versions of the GT sensor product line plus our DD001-12 stand-alone signal processing IC. A variety of PCB configurations are provided so that the parts can be tested in different housing and barrel sizes including the M8 housing. Magnets for biasing are also included.

Evaluation kits may be ordered direct from NVE's web site or from our authorized distributors. See NVE's web site for the list of authorized distributors.

**AG001-01 Analog Sensor Evaluation Kit**

The NVE GMR Engineering Evaluation Kit (PN AG001-01) was created as an aid to the technical user of GMR sensors to facilitate laboratory experimentation and development. The kit consists of an assortment of NVE sensors, printed circuit boards and permanent magnets sufficient to demonstrate sensor functionality in the laboratory. The kit consists of the following:

<u>Part Number</u>	<u>Quantity</u>	<u>Description</u>
AA002-02	2	15 Oe/5 kΩ Field Sensor
AAH002-02	1	6 Oe/2 kΩ Field Sensor
AAL002-02	1	15 Oe/5 kΩ Field Low Hysteresis Sensor
AA003-02	2	20 Oe/5 kΩ Field Sensor
AA004-02	2	50 Oe/5 kΩ Field Sensor
AA005-02	2	100 Oe/5 kΩ Field Sensor
AA006-02	2	50 Oe/30 kΩ Field Sensor
AB001-02	2	250 Oe/5 kΩ Field Gradient Sensor
AG004-06	2	Long PCB- 3.0" x 0.3"
AG005-06	2	Square PCB- 0.5" x 0.5"
SN 12031	2	Ceramic 5- Disc Magnets
SN 12030	2	Ferrite Rectangular magnets



## AG003-01 Current Sensor Evaluation Kit

The NVE GMR Current Sensor Evaluation Assembly (P/N AG003-01) was created to facilitate laboratory experimentation and development using GMR current sensors. The kit consists of (4) four NVE current sensors (P/N AA003-02) assembled to a printed circuit board (P/N AG002-01). Please note that the AA003-02 was selected for inclusion in this kit because it is a good medium sensitivity current sensor. In fact, any of NVE’s AA sensor products can be used in this application for more or less sensitivity to the magnetic field generated by the current. The PCB included in the kit has (4) four trace geometries to simulate various PCB current ranges. The details are as follows:

Trace no.	Trace Width (inches)	Maximum <sup>1</sup> Trace Input Current (A)	Nominal Sensitivity ( $[mV/V]_{out}/A_{in}$ )
1	0.090	±9.0	3.5
2	0.060	±6.0	3.7
3	0.010	±0.25	4.0
4	7 x 0.010	±0.25	20.0

**Notes:**

1. The maximum current is based on the rated current carrying capability of each trace geometry.
2. The minimum current the assembly can sense is arbitrary. The absolute value is dependent on many system design parameters and must be determined by the user.
3. For functional characteristics of the AA003-02 current sensor refer to the AA Sensors section of this catalog.
4. Refer to NVE’s Engineering & Application Notes, Appendix APP 003, “GMR Current Sensing” for additional technical details.
5. The AG003-01 assembly can be subdivided into (4) four separate sub-assemblies. All connections to each input trace and current sensor are isolated on each sub-section.

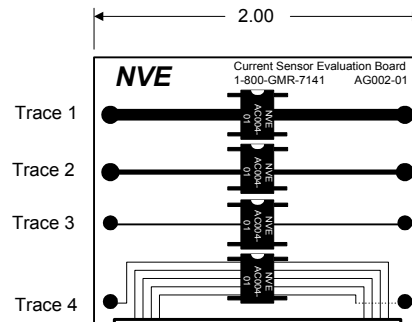

## AG910-07 and AG911-07 GMR Switch Evaluation Kits

These kits were created to facilitate laboratory experimentation and development using NVE's GMR Switch Digital Output Sensors. The kits consist of sixteen distinct NVE GMR Switches that span the magnetic field range and output types available in the AD-Series sensors. All sensors in this kit are packaged in the MSOP8 miniature surface mount package. The kits also include a ceramic bar magnet and printed circuit boards (PCBs) for testing in the actual application. In addition, the AG910-07 kit includes a high temperature (175°C) MSOP8 ZIF socket with Kelvin contacts.



### GMR Switch Digital Evaluation Kits Parts List

Part Designator	Part Marking	Output type	Description
AD004-00	BBH	Single Current Sink	See GMR Switch Section of This Catalog
AD005-00	BBG		
AD006-00	BBJ		
AD020-00	BBK		
AD021-00	BBB		
AD022-00	BBC		
AD023-00	BBD		
AD024-00	BBF		
ADH025-00	MBL		
AD105-00	DBG		
AD122-00	DBC	"	
AD824-00	MBF	Dual Output with SCP	
AD924-00	NBF	"	
AD320-00	GBK	Sink/Sink	
AD324-00	GBF	"	
AD624-00	KBF	Sink/Source/Vreg	
AD724-00	LBF	Sink/Sink/Vreg	
AG910-06	N/A	N/A	1"x2" PCB Board (AG910-07 Kit Only)
AG918-06	N/A	N/A	.25" X 2" PCB Board
AG919-06	N/A	N/A	.25" X 2" PCB Board
SN 12100	N/A	N/A	MSOP8 ZIF Socket (AG910-07 Kit Only)
SN 12032	N/A	N/A	Ceramic Magnet, 1"x0.25"x0.39"

**AG920-07 GT Sensor Evaluation Kit**

This kit was created to facilitate laboratory experimentation and development using NVE’s GT Sensor products. Because of the wide variety of mechanical orientations where these sensors can be used, this kit contains a large variety of circuit boards to simplify the customer’s fixturing and testing of the parts. Included in the kit are one of each type of NVE’s GT Sensor products, both analog and digital, plus two of the DD001-12 signal processing ICs to convert the analog output of the ABL sensors digital. The contents are listed below:



Quantity	Part Number	Marking	Description
1	ABL004-00	FDB	Single Differential Sensor, 1.0mm Element Spacing
1	ABL005-00	FDC	Single Differential Sensor, 0.5mm Element Spacing
1	ABL014-00	FDD	Dual Differential Sensor, 1.0mm Element Spacing, 0.5mm Phase Shift
1	ABL015-00	FDF	Dual Differential Sensor, 0.5mm Element Spacing, 0.25mm Phase Shift
1	AKL001-12	P/N	Digital Output Differential Sensor, 1.0mm Element Spacing
1	AKL002-12	P/N	Digital Output Differential Sensor, 0.5mm Element Spacing
2	DD001-12	P/N	Digital Output Signal Processing IC for ABL Sensors
2	AG915-06	N/A	M8 Round PCB, for mounting ABL Sensor
2	AG914-06	N/A	M10 Round PCB, for mounting AKL Sensor
1	AG918-06	N/A	Long, Narrow PCB for Mounting ABL Sensor Parallel to Long axis
1	AG919-06	N/A	Long, Narrow PCB for Mounting ABL Sensor Perpendicular to Long axis
1	AG913-06	N/A	PCB for Mounting 2 DD001-12 ICs
1	AG916-06	N/A	Long, Narrow PCB for Mounting AKL Sensor Perpendicular to Long axis
1	AG917-06	N/A	Long, Narrow PCB for Mounting AKL Sensor Parallel to Long axis
1	AG911-06	N/A	Long, Narrow PCB for Mounting ABL Sensors Parallel to Long axis, and 1 or 2 DD001-12 ICs
1	AG912-06	N/A	Long, Narrow PCB for Mounting ABL Sensors Perpendicular to Long axis, and 1 or 2 DD001-12 ICs
5	12216	N/A	6mm Diameter X 4mm Thick Round Ferrite Magnets
5	12217	N/A	3.5mm Diameter X 4mm Thick Round Ferrite Magnets

## Application Notes for GMR Sensors

### Contact Information

NVE Information line: (800) 467-7141

Specific Product or Company Information:  
(952) 996-1605 email: [info@nve.com](mailto:info@nve.com)

Customer Applications Engineering:  
(952) 829-9173 email: [apps@nve.com](mailto:apps@nve.com)

NVE Internet Home Page: [www.nve.com](http://www.nve.com)

*NVE reserves the right to make product changes and improvements at any time.*

*The information contained herein is believed to be accurate as of the date of printing, however NVE assumes no responsibility for its use. Any errors in the technical data printed in this catalog will be corrected and updated as soon as possible. The most recent copy of this catalog and application notes will be available online at [www.nve.com](http://www.nve.com).*

**If application questions or concerns exist, please contact NVE prior to use of the products.**

**General Comments**

NVE GMR sensors are designed to measure or sense magnetic field strength over a wide range of fields. GMR sensors directly detect magnetic field rather than the rate of change in magnetic field; therefore, they are useful as DC field sensors. NVE's GMR sensors are sensitive to small changes in magnetic fields. This allows for accurate measurement of position or displacement in linear or rotational systems. The extremely small size of the sensing element enhances the position sensitivity, especially in applications incorporating small magnets and large field gradients. Magnetic fields produced by current carrying conductors make our devices usable as current sensors or detectors.

**Competitive Technologies**

GMR sensors have greater output than conventional anisotropic magnetoresistive (AMR) sensors or Hall effect sensors, and are able to operate at fields well above the range of AMR sensors. In addition, high fields will not "flip" GMR sensors or reverse their output as is possible with AMR sensors. High fields will also not cause damage to NVE GMR sensors, as is the case with some competing GMR sensor products.

The output of GMR sensors is frequency insensitive up to 1 MHz. GMR sensors produce an output with a constant field. This sets them apart from inductive (variable reluctance) field sensors, which respond only to changes in magnetic field. High resistivity GMR material enables the fabrication of sensors with high resistance. Sensors with 5 k $\Omega$  resistance is standard. Special low power devices can be manufactured with 30 k $\Omega$  or higher resistance. Sensors can also be fabricated with built-in offset at zero field that provide for a zero crossing in output at a specified field value.

**GMR Material Physics**

The giant magnetoresistive phenomenon, discovered in 1988, is an effect found in metallic thin films consisting of magnetic layers a few nanometers thick separated by equally thin nonmagnetic layers. Researchers observed a large decrease in the resistance with a magnetic field applied to the films. This effect is based partly on the increasing resistivity of conductors as their thickness decreases to a few atomic layers. In bulk material form, conduction electrons in these materials can travel a long distance before “scattering,” or changing direction, due to a collision with another atomic particle. The average length that the electron travels before being scattered is called the mean free path length. However, in materials that are very thin, an electron cannot travel the maximum mean free path length; it is more likely that the electron will reach the boundary of the material and scatter there, rather than scatter off another atomic particle. This results in a lower mean free path length for very thin materials. It is therefore more difficult for conduction electrons to travel in this material, and the result is higher electrical resistivity. The chart below shows the relationship between resistivity of a magnetic material such as iron or nickel, and the thickness of the material at very small dimensions. For purposes of scale, one nanometer equals ten Angstroms; a copper atom has a diameter of about 3 Angstroms:

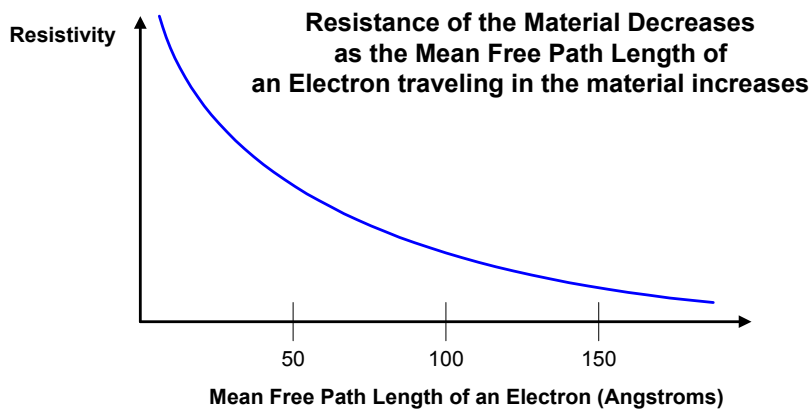

In order to take advantage of this effect, GMR films are manufactured with very thin layers of alternating magnetic and non-magnetic materials. This is done to allow magnetic modulation of the electron spin in the materials. The spin dependence of conduction electrons in magnetic materials, along with the increasing resistivity at very small material thicknesses, combine to make the GMR effect possible.

The figure below shows a simplified structure of a typical GMR sensor film, as manufactured by NVE:

### Cross Sectional Structure of Basic GMR Material

<b>Top Film (Magnetic Material, 20-50 Angstroms Thick)</b>
<b>Conductive Interlayer (Non-Magnetic Material, 15-40 Angstroms Thick)</b>
<b>Bottom Film (Magnetic Material, 20-50 Angstroms Thick)</b>

The diagram shows two magnetic material layers, sandwiching a non-magnetic interlayer. The magnetic layers are designed to have anti-ferromagnetic coupling. This means that the magnetization of these layers is opposite to each other when there is no external magnetic field applied to the material. Antiferromagnetic coupling can be visualized by imagining two bar magnets on either side of a thin sheet of plastic. The magnets couple head to tail (north pole to south pole) across the boundary formed by the plastic. In a similar fashion, the magnetization direction of the magnetic layers in the GMR film couple head to tail across the non-magnetic interlayer of the film.

The conduction electrons in magnetic materials have a spin characteristic. The electrons are normally referred to as spin up electrons when the material is magnetized in one direction, and spin down electrons when the material is magnetized in the opposite direction.

The diagram below shows some electron paths inside the GMR material structure. The two arrows indicate the antiferromagnetic coupling. Notice that the electrons tend to scatter off the two GMR material interfaces. This is because the electrons from the spin up layer are trying to enter the spin down layer, and vice versa. Because of the differences in the electron spins, it is more likely that the electrons will scatter at these interfaces:

**Spin UP Electrons Scatter at Interface with Spin DOWN Layer;  
Spin DOWN Electrons Scatter at Interface with Spin UP Layer  
Average Mean Free Path of the Electrons is Short**

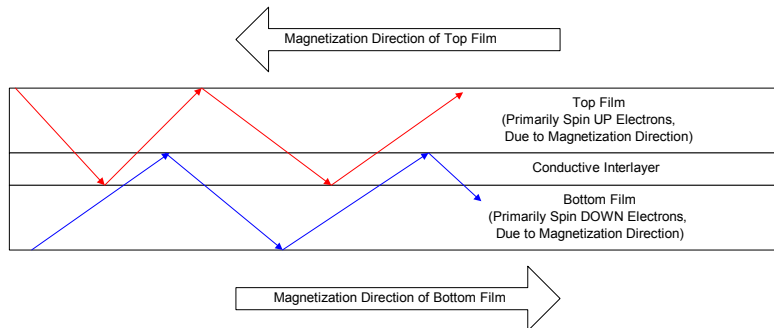

The end result in this case is that the mean free path length of the conduction electrons is fairly short, resulting in a relatively high electrical resistance.

If an external magnetic field of sufficient magnitude is applied to this GMR material, it will overcome the antiferromagnet coupling of the magnetizations between the two magnetic layers. At this point all the electrons in both films will have the same spin. It will then become easier for the electrons to move between the layers:

**Spin States of the Magnetic Layers are the same;  
Electrons Travel More Readily Through Entire Stack of GMR Material.  
Average Mean Free Path of the Electrons is Long**

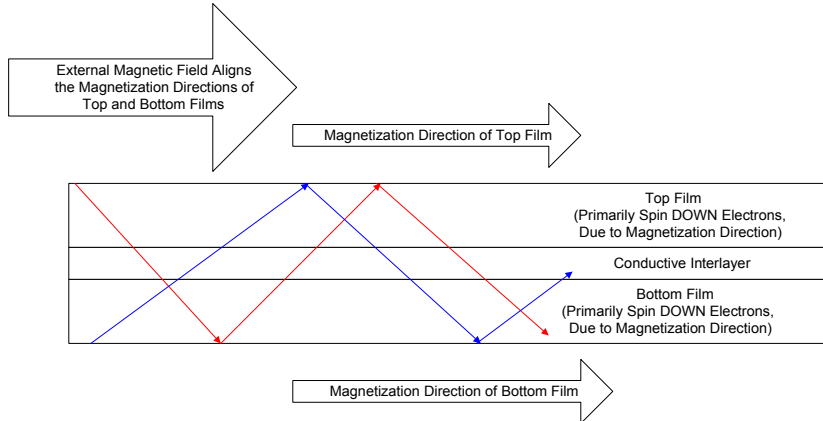

Note that the mean free path length of the electrons has now increased. This results in an overall lower electrical resistance for the GMR material. The change in resistivity of the material is shown on the path length diagram below:

**Resistivity Plot Showing Operate Points of GMR Material  
With and Without an External Magnetic Field Applied;  
Applying the External Field Results in Lower Device Resistance**

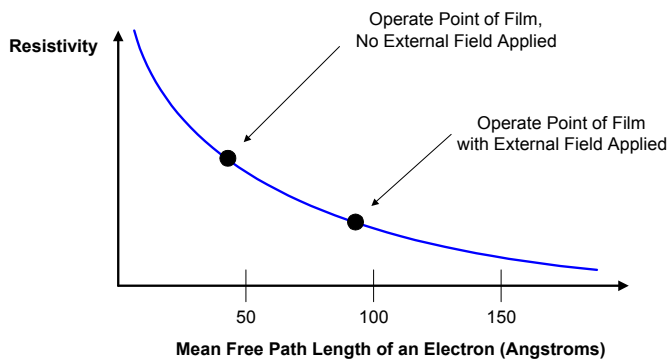

This change in resistance is the GMR effect.

The size of the resistance decrease is typically 4% to over 20%, depending on the material structure of the GMR films. Most of NVE's sensor products rely on a GMR material which exhibits 14% to 16% decrease in resistance. The "percent GMR" of a given material is calculated using the following formula:

$$\% \text{ GMR} = \text{Change in Resistance} / \text{Minimum Resistance}$$

For example, assume an electrical resistor is implemented with GMR material, and it shows a nominal resistance of 5000 Ohms. Then a magnetic field is applied and with this field a minimum resistance of 4400 Ohms is achieved. The percent GMR is then 600/4400, or about 13.6%.

Not all GMR materials operate in the manner described above. All GMR materials rely on modulating the difference between the magnetization directions of adjacent layers in the GMR film structure, but some achieve this modulation in different ways. The other most common type of GMR material is referred to as a "spin valve" GMR material. This type of material does not necessarily rely on anti-ferromagnetic coupling of the adjacent magnetic layers in the GMR film. In this case one of the magnetic layers is "pinned," or fixed with respect to its magnetization direction. The magnetization direction of the pinned layer will not move when exposed to normal operating magnetic fields. Therefore, the externally applied magnetic field will modulate the direction of the other magnetic layer, referred to as the "free" layer. As the angle between the free layer and the pinned layer varies, the mean free path length of the electrons in the GMR film also varies, and therefore the electrical resistance will change.

Fixing the magnetization direction of the pinned layer in spin valve GMR materials can be done in a variety of ways. However, it is important that the layer is pinned in a robust manner; otherwise, the pinning can be undone by application of a large magnetic field. This will destroy the operation of the sensor. NVE uses the application of large magnetic fields and high anneal temperatures (over 240°C) to set the pinned layer of the film. This layer *cannot* be unpinned with the application of any magnetic field in the normal temperature range of operation. Therefore, the sensor cannot be damaged by large magnetic fields. This is also true of NVE's other GMR sensors; no damage to any NVE GMR sensor product can result due to the application of extremely large magnetic fields.

One of NVE's competitors in Europe introduced a GMR sensor in 1997 that could be damaged by magnetic fields in the 250 Gauss range. This product has since been discontinued.

## GMR Materials Types Manufactured by NVE

NVE manufactures four different types of GMR materials for use in our sensor products. These GMR materials are described below:

**Standard Multilayer (ML)** – This GMR material has AF (antiferromagnet) coupling, % GMR in the range of 12% to 16%, magnetic saturation fields of about 300 Oersteds, stable temperature characteristics for operation up to 150°C, and moderate hysteresis.

**High Temperature Multilayer (HTM)** – This GMR material has AF coupling, % GMR in the 8% - 10% range, magnetic saturation fields of about 80 Oersteds, stable temperature characteristics for operation up to 200°C, and high hysteresis.

**Low Hysteresis High Temperature Multilayer (LHHTM)** – This GMR material is AF coupled, has % GMR in the range of 8% - 10%, magnetic saturation fields of about 180 Oersteds, stable temperature characteristics for operation up to 200°C, and low hysteresis.

**Spin Valve (SV)** – This GMR material has one pinned layer, has % GMR in the range of 4% - 5%, magnetic saturation fields of about 25 Oersteds, stable temperature characteristics for operation up to 200°C, and nearly zero hysteresis when operated in saturation mode.

The following table gives a brief comparison of these different GMR materials, and indicates in which product prefix they are used:

GMR Material	% GMR	Saturation Field (Oe)	Temperature Range	Hysteresis	Product Prefixes
ML	12%-16%	250 - 450	-40 - +150	Medium	AA, AB, AD
HTM	8%-10%	60 - 100	-40 - +200	High	AAH, ABH, ADH
LHHTM	8%-10%	160 - 200	-40 - +200	Low	ABL
SV	4%-5%	20-30	-40 - +200	Low	AAV

In addition to these materials, NVE is currently developing more specialized GMR materials for various sensor applications, including a bipolar output low hysteresis material and a spin dependent tunneling material. Please check our web site for new product releases based on these new GMR materials.

## Temperature Characteristics of GMR Sensors

Temperature excursions cause several changes to the characteristics of GMR sensors. The changes are described below:

1. Changes to base resistance of the sensor element [TCR] – This is a temperature coefficient of resistance of the sensor element with no applied magnetic field to the sensor. The TCR is normally given in %/°C.
2. Changes to the % GMR of the sensor element [TCGMR] – When a magnetic field is applied, the % GMR exhibited by the sensor element will change. Generally as temperature increases, % GMR decreases. TCGMR is normally given in %/°C.
3. Changes to the saturation field of the sensor element [TCHsat] – The magnetic field at which the sensor will provide its maximum output will also change with temperature. The saturation field (Hsat) will decrease as temperature increases. TCHsat is normally given in %/°C.

For purposes of temperature compensation, a single resistor sensor element made from GMR material can be modeled as two resistors in series. The first resistor is the base resistive element, and is a constant resistance at a given temperature, regardless of the applied magnetic field. The second resistor represents the changing resistance of the single resistor sensor element made from GMR material, as magnetic field is applied. This model is shown in the following diagram:

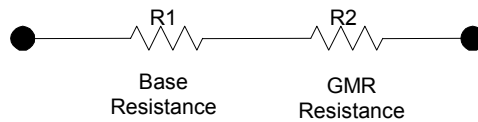

The base resistance of R1 is the resistance of the sensor element at 25°C when the saturating magnetic field is applied and R2 has dropped to 0 resistance; in other words, the minimum resistance of the sensor element as described in the GMR Material Physics section. The following formula can be used to compute R1 at various temperatures:

$$R1 = R1 \text{ Base Resistance} * [ 1 + (TCR * (Temperature - 25^\circ C))] ]$$

The resistance of R2 in the diagram varies both with the temperature and the applied magnetic field. The base resistance of R2 is defined as its maximum resistance at 25°C. This is the resistance with zero applied magnetic field. The base resistance of R2 will vary with temperature (at zero applied field) as described by the following formula:

$$R2_{\text{Zero Field}} = R2 \text{ Base Resistance} * [ 1 + (TCGMR * (Temperature - 25^\circ C))] ]$$

When a magnetic field is applied to R2, its resistance will vary in a generally linear fashion with the applied field, from zero up to the saturation field (Hsat). After the GMR material's saturation field is reached, applying additional magnetic field will not result in changes to the resistance of the device.

The complete equation for R2, taking into account both the changes in % GMR with temperature and the changes in Hsat with temperature, and assuming operation of the sensor element at magnetic fields less than the Hsat value, is given below:

$$R2 = R2_{\text{Zero Field}} * [1 - (AF / HsatT)]$$

Where:

AF = Applied Magnetic Field

HsatT = Hsat@25°C \* [1 - (TCHsat \* (Temperature - 25°C))]

Please note that although the equations provided above result in linear results, the actual GMR devices are not perfectly linear. In particular, the transition of the output characteristic as it enters magnetic saturation is rounded, and can be seen in the temperature performance graphs of the various GMR materials shown at the end of this section. In addition, non-linearities also exist in some cases near the zero field range of the devices. The best fit for the formulas provided above is in the linear operating range of each sensor element as defined in the product specifications.

In addition, the effects of flux concentration and shielding in the sensor element are not reflected in these equations, nor is any effect from hysteresis included.

In many cases, an analysis of the complete temperature characteristic of the device is not required; the only important parameter is how the output of the sensor device itself changes with temperature. In this case, it is important to know if the sensor is being supplied with a constant voltage source or a constant current source. If a constant current source is used, the voltage across the sensor can increase as the resistance of R1 increases with temperature, thus mitigating some of the signal loss effects with temperature.

NVE has defined the following two terms to describe the change in signal output with temperature:

**TCOV:** Temperature Coefficient of the Output with a constant Voltage (V) source; given in %/°C.

**TCOI:** Temperature Coefficient of the Output with a constant Current (I) source; given in %/°C.

These numbers will provide an accurate indication of the change in the output of the parts over temperature in the linear operating range. Note that this data is provided for NVE's AA and AB type parts but not for any of the parts that include a signal processing IC in the package. This is because NVE typically builds temperature compensation circuitry into the signal processing IC.

The following table summarizes the temperature coefficients described in the preceding paragraphs for the GMR materials used in most of NVE's products:

GMR Material Type	ML	HTM	LHHTM
Product Series	AA, AB, AD	AAH, ABH	AAL, ABL, AKL
TCR (%/C)	+0.14	+0.11	+0.11
TCGMR (%/C)	-0.10	-0.38	-0.38
TCHsat (%/C)	-0.10	-0.45	-0.25
TCOI (%/C)	+0.03	+0.10	-0.28
TCOV (%/C)	-0.10	0.0	-0.40

The following graphs show the basic temperature behavior of the three most common types of GMR materials used in NVE's products. The first graph shows the temperature behavior of an AA002-02 sensor, which is representative of the GMR material used in NVE's AA, AB, and AD-Series products:

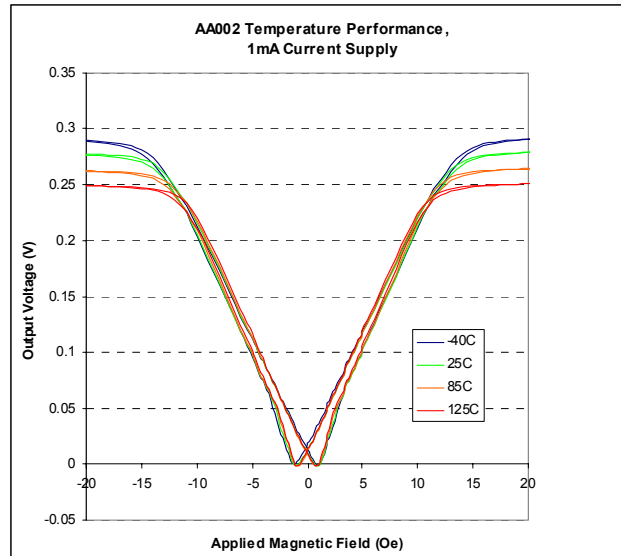

The next graph shows the temperature behavior of an AAH002-02 sensor, which is representative of the GMR material used in NVE's AAH and ABH-Series products:

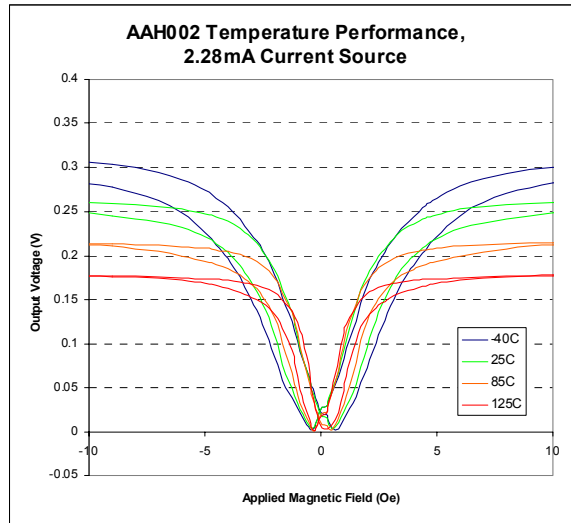

The next graph shows the temperature behavior of an AAL002-02 sensor, which is representative of the GMR material used in NVE's AAL, ABL, and AKL-Series products:

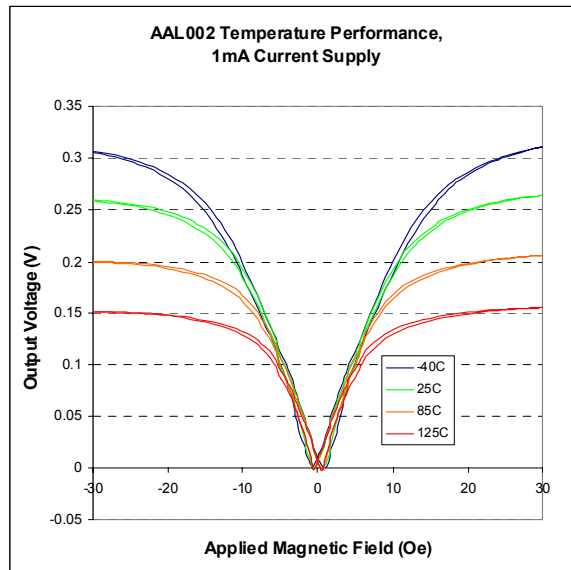

## Hysteresis in GMR Sensors

All magnets and magnetic materials (iron, nickel, etc.) have magnetic hysteresis. Hysteresis refers to the history of the magnetic field applied to the material and how it affects the material properties and performance. NVE's GMR sensors are made of magnetic materials, so they are subject to hysteresis effects.

Hysteresis can make GMR sensors easier or harder to use, depending on the application. In nearly all digital applications, hysteresis is desirable because it prevents "jitter" at the sensor operate point. With sensor elements that do not have hysteresis, electrical hysteresis is normally built into the signal processing electronics.

In a linear application, hysteresis can be problematic, but this depends on the application. For example, if a GMR sensor is used as a current sensor, and it is detecting the magnetic field from a repetitive current such as a sinusoidal waveform, then the recent magnetic history at sensor will always be the same. This will result in repeatable output from the sensor at each current level. In this case, hysteresis is not an issue. Another important point is that time is not a factor, only the magnitude of the fields that the sensor is exposed to. For example, if the frequency of the current's sinusoidal waveform changes, or if the current stops at a given level for some period of time, and then restarts in the same sinusoidal pattern, there will be no hysteresis effects at the sensor.

On the other hand, if the magnetic field to be detected is not repetitive in magnitude, but more random in nature, then an error can result in the sensor output reading. The size of this error will depend on the amount of hysteresis in the sensor element and the difference in the polarity and magnitudes of the applied fields that the sensor was recently exposed to. The error will take the form of a voltage offset change in the sensor element.

Because the error is essentially an offset change, it can be eliminated in cases where the signal is high in frequency by AC coupling the output of the sensor to an amplifier. This is a common solution in applications such as currency detection where a very small signal that can be random in nature must be detected from a moving object. AC coupling and a high gain amplifier are employed to see this small signal with GMR sensors.

If DC coupling the sensor to an amplifier or output stage is required, and the magnetic field will not be repeatable, then the hysteresis in the sensor element must be taken into account as a potential error in the reading. For NVE's AA-Series sensors, this potential error can be as high as 4% if the sensor is exposed to one polarity of magnetic field (unipolar mode of operation), and as high as 20% if the sensor is exposed to a bipolar field. However, even in these cases the large output signal of the GMR sensor elements can provide advantages over other technologies.

The polarity of the magnetic field that is applied to the sensor has a strong effect on the amount of hysteresis. Unipolar operation is when the applied magnetic field at the sensor is always in the same polarity, or direction. Bipolar operation is when the magnetic field at the sensor changes direction. Hysteresis is much more exaggerated in the sensor element when a bipolar magnetic field is applied to the sensor.

The following chart shows the output of an AA-Series sensor when it is exposed to a saturating unipolar field:

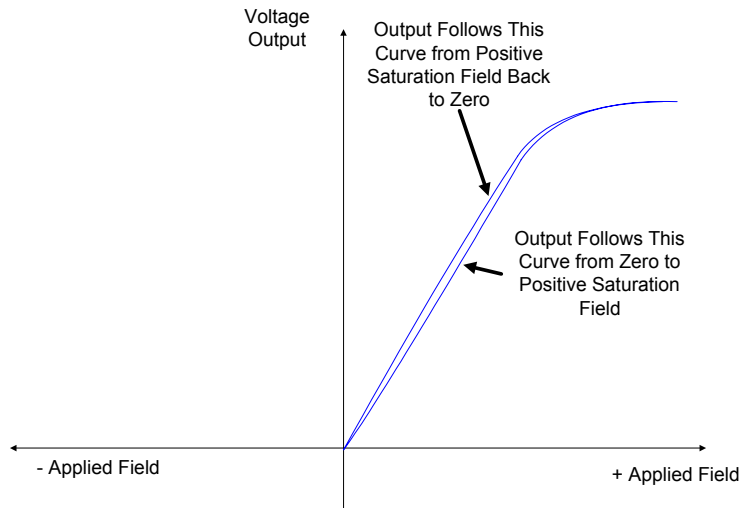

In the case of a unipolar field, the sensor is operating on the minor hysteresis loop. The hysteresis in this case is relatively small.

The following chart shows the output of the same sensor when it is exposed to a saturating bipolar field:

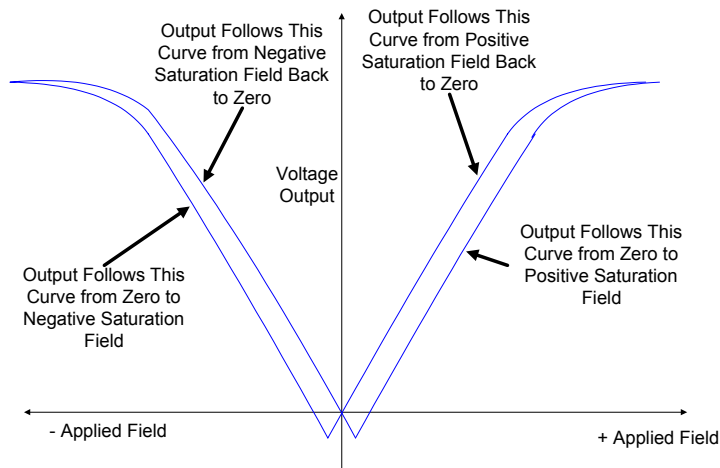

In this case the sensor is operating on the major hysteresis loop, so the hysteresis shown by the output characteristic of the sensor is relatively large. This is the worst-case hysteresis exhibited by the sensor element.

After-saturation effects are important in understanding how the sensor behaves. It is important to note that after the sensor is saturated by a magnetic field, either in the positive or negative direction, it returns to zero field along the inside curve of the major loop characteristic. As shown in the diagram below, a negative saturating field applied to the sensor, followed by a small positive field, will result in a negative voltage output:

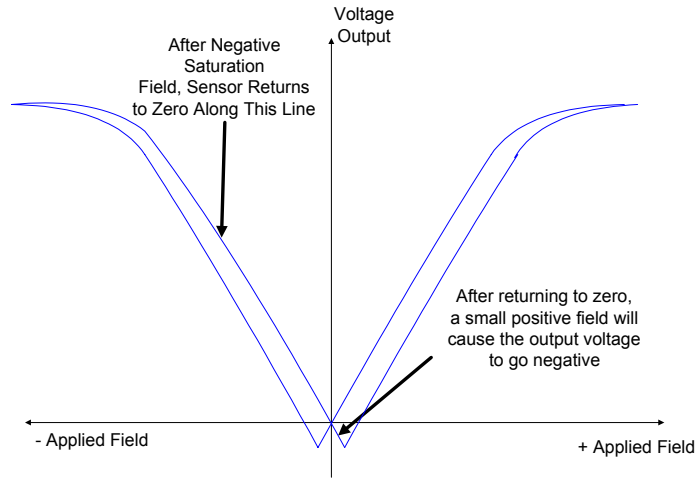

The same small positive field, applied after a positive saturating field, will result in a positive voltage output:

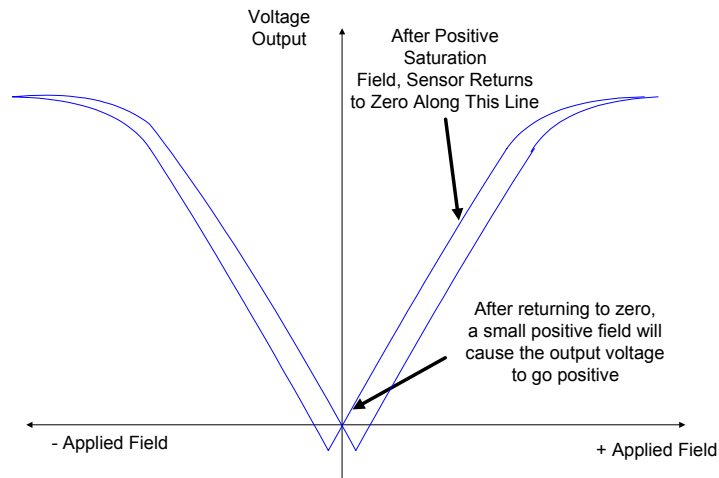

This confusing result is often seen when trying to detect very small magnetic fields such as the earth's field in magnetic compass applications or currency detection applications. The solution to this problem is to bias the sensor element with an external magnetic field, so that the operating point of the sensor is on the linear portion of the characteristic curve. This can be done either with an external permanent magnet, or a current running near the sensor. Biasing the sensor with a positive external field from a magnet or current will shift the sensor's output characteristic as shown below:

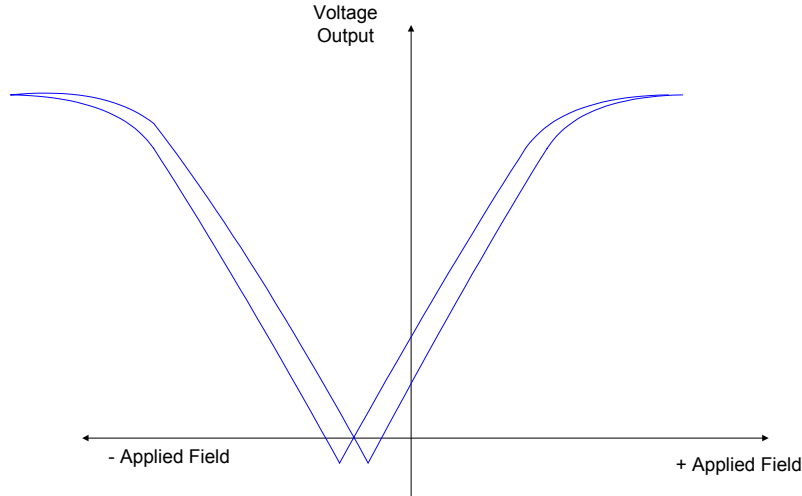

With this approach, a small applied field to the sensor will result in a bipolar output signal. Furthermore, the slope of the signal characteristic will be the same no matter which curve the sensor is operating on. So, the magnetic sensitivity of the device is the same, no matter how much hysteresis the sensor has.

Also important to note regarding hysteresis is that it scales with the applied magnetic field. For applications where the magnetic field variations are small, hysteresis is small. The following diagram illustrates this point:

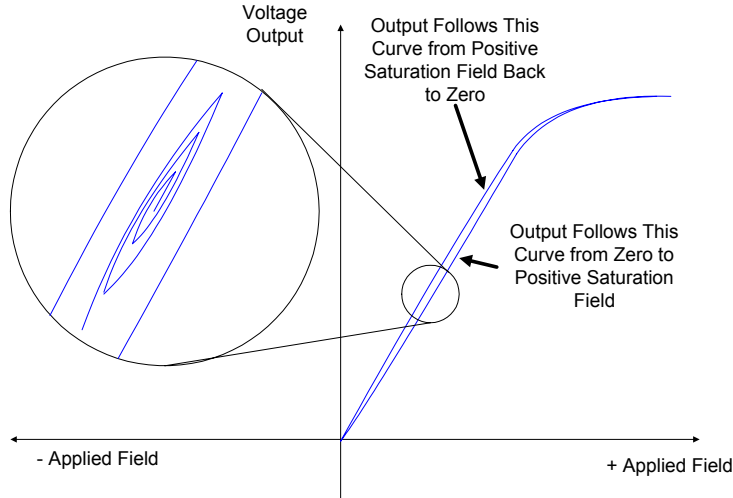

The enlarged area on the left shows the outer boundaries of the sensor hysteresis loop when it is operated in unipolar mode (positive magnetic fields only). Inside the outer boundaries is the sensor behavior if it is exposed to small but increasing magnetic fields. For example, if this was the characteristic of an AA002-02 sensor, the magnetic field history for the characteristic between the boundaries might start at 6 Gauss, then go to 6.5, then 5.5, then 7, then 7.5, and so forth. The curvature of the lines between the boundaries is exaggerated for clarity. The diagram shows that for small variations of the magnetic field, the hysteresis is also small, and as the variations in field increase, so does the hysteresis.

Sensor hysteresis presents challenges in some applications, but in most cases the sensor elements can be used to advantage despite the hysteresis characteristics.

**GMR Magnetic Field Sensors (Magnetometers)**

The NVE standard line of magnetic field sensors use a unique configuration employing a Wheatstone bridge of resistors and various forms of flux shields and concentrators. Using magnetic materials for shielding eliminates the need for a bias field with GMR sensors. NVE has developed a process to plate a thick layer of magnetic material on the sensor substrate. This layer forms a shield over the GMR resistors underneath, essentially conducting any applied magnetic field away from the shielded resistors. The configuration allows two resistors (opposite legs of the bridge) to be exposed to the magnetic field. The other two resistors are located under the plated magnetic material, effectively shielding them from the external applied magnetic field. When the external field is applied, the exposed resistors decrease in electrical resistance while the other resistor pair remain unchanged, causing a signal output at the bridge terminals.

The plating process developed by NVE for use in GMR sensor applications has another benefit: it allows flux concentrators to be deposited on the substrate. These flux concentrators increase the sensitivity of the raw GMR material by a factor of 2 to 100. The flux concentration factor is roughly equivalent to the length of one shield divided by the length of the gap. This allows use of GMR materials that saturate at higher fields. For example, to sense a field from 0 to 100 Oersteds, NVE deposits a GMR sensor that saturates at a nominal 300 Oersteds and flux concentrators with a magnification factor of three. The figure below shows the basic layout of the device:

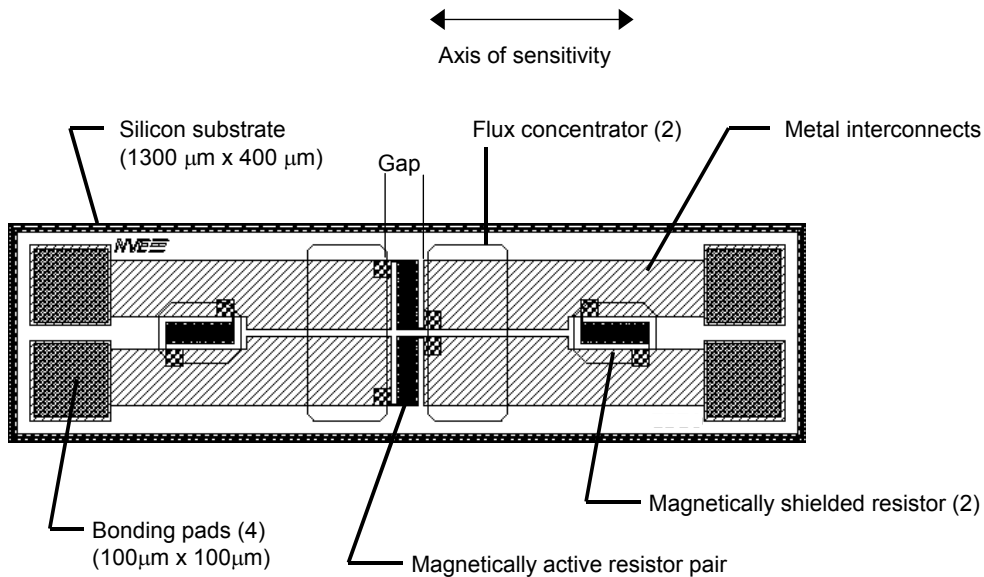

*TYPICAL GMR MAGNETIC FIELD SENSOR LAYOUT*

The magnetic characteristic of a shielded bridge device is shown below. This characteristic was taken from an actual production device with 5V supplied to the bridge power terminals (5 kΩ bridge).

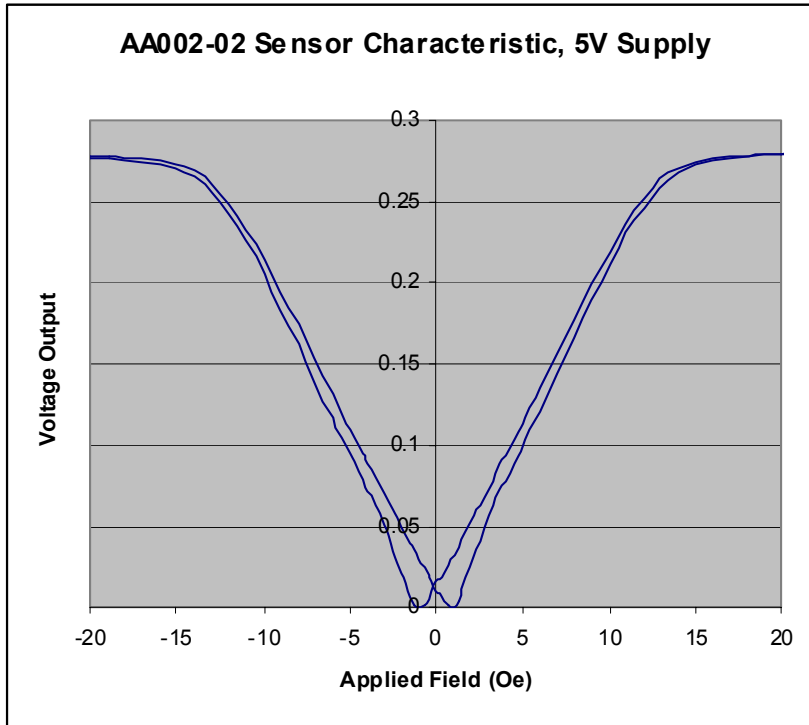

### *GMR MAGNETIC FIELD SENSOR OUTPUT CHARACTERISTIC*

This signal output can be coupled directly into a linear amplifier or a comparator to generate a high level electrical signal proportional to the strength of the magnetic field seen by the sensor.

**GMR Magnetic Gradient Sensors (Gradiometers)**

The NVE gradiometer is a GMR magnetic field sensor used to detect field gradients between Wheatstone bridge configured resistors. This device is “unshielded” (*i.e.*, it does not employ resistor shields) therefore all four (4) legs of the Wheatstone bridge are active (they respond to changes in field level). Gradiometers can be used to detect either magnetic or ferrous targets. To detect gradient changes caused by the proximity to a moving ferrous target, a biasing magnet is required. Refer to the Magnetic Biasing section and the GT Sensor application notes for gradiometer biasing guidelines.

The output of the gradiometer differs from that of a standard GMR Magnetic Field Sensor. The gradiometer’s output can be bipolar versus unipolar and can be shaped by the use of magnetic biasing and the application of external flux shaping devices (flux guides). The figure below shows an example design:

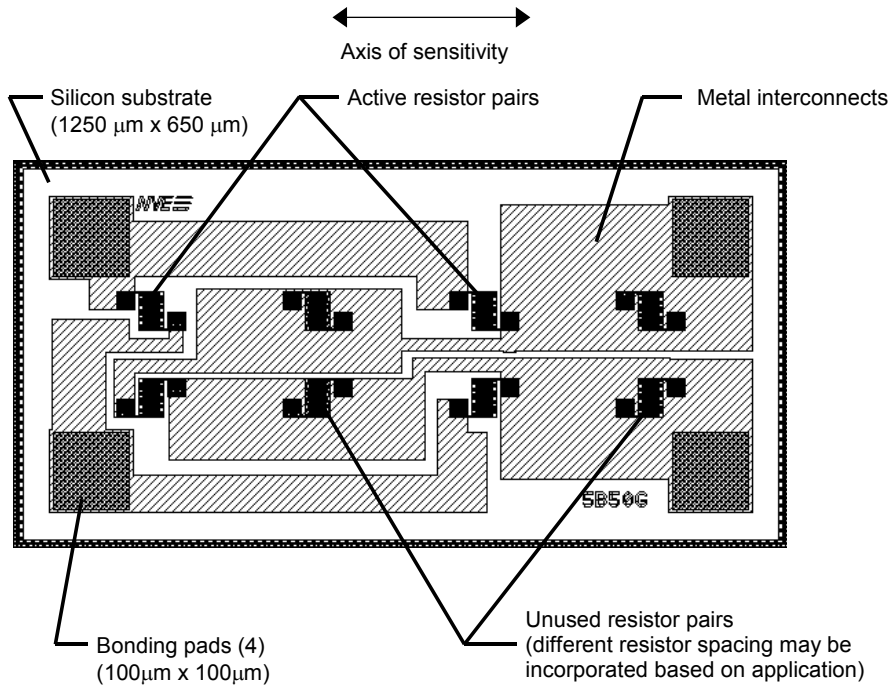

*BASIC GRADIOMETER BRIDGE SENSOR LAYOUT*

The following graph shows the output characteristic from a gradiometer as the field gradient is varied across the sensor IC:

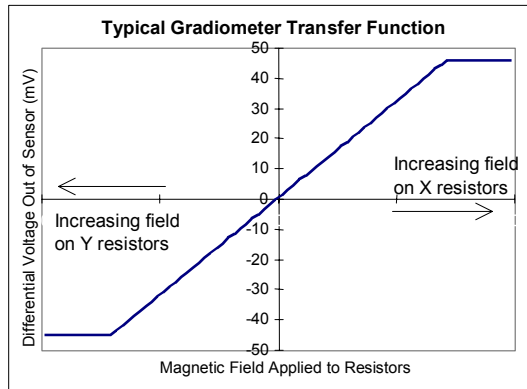

## GRADIOMETER BRIDGE SENSOR OUTPUT CHARACTERISTIC

## Magnetic Reference Information

### Permanent Magnets

The Magnetic Materials Producers Association (MMPA) publishes two reference booklets with valuable reference information on basic magnetic theory, permanent magnet materials and their practical application. They are:

- MMPA Standard no. 0100-96  
Standard Specifications for Permanent Magnet Materials
- MMPA PMG-88  
Permanent Magnet Guidelines

These booklets can be obtained from the MMPA:

- Magnetic Materials Producers Association  
8 South Michigan Ave., Suite 1000  
Chicago, IL 60603  
(312) 456-5590  
(312) 580-0165 (fax)

### Measurement Systems

Unit	Symbol	cgs System	SI System	English System
Length	L	centimeter (cm)	meter (m)	inch (in)
Flux	$\phi$	maxwell	weber (Wb)	maxwell
Flux density	B	gauss (G)	tesla (T)	lines/in <sup>2</sup>
Magnetizing force	H	oersted (Oe)	ampere turns/m (At/m)	ampere turns/in (At/in)
Magnetomotive force	F	gilbert (Gb)	ampere turn (At)	ampere turn (At)
Permeability in air	$\mu_0$	1	$4\pi \times 10^{-7}$	3.192

Conversion factors for between measurement systems can be found in the appendix to this catalog.

## Signal Conditioning Circuits

A number of methods exist for pre-amplification of an NVE GMR bridge sensor output. This section shows some representative circuits and compares the relative advantages and disadvantages of some common configurations. The circuits shown were designed for low power and 5V operation. Low noise or high performance applications should be designed with lower noise, higher performance components.

### Operational Amplifier (Op Amp) Bridge Preamplifier Circuits

#### Single Op Amp Bridge Amplifier

The figure below shows a simple circuit for amplifying an NVE AAxxx-02 GMR Magnetic Field Sensor's bridge output using a single 5V supply. The advantages of this configuration are simplicity, low component count, and low cost.

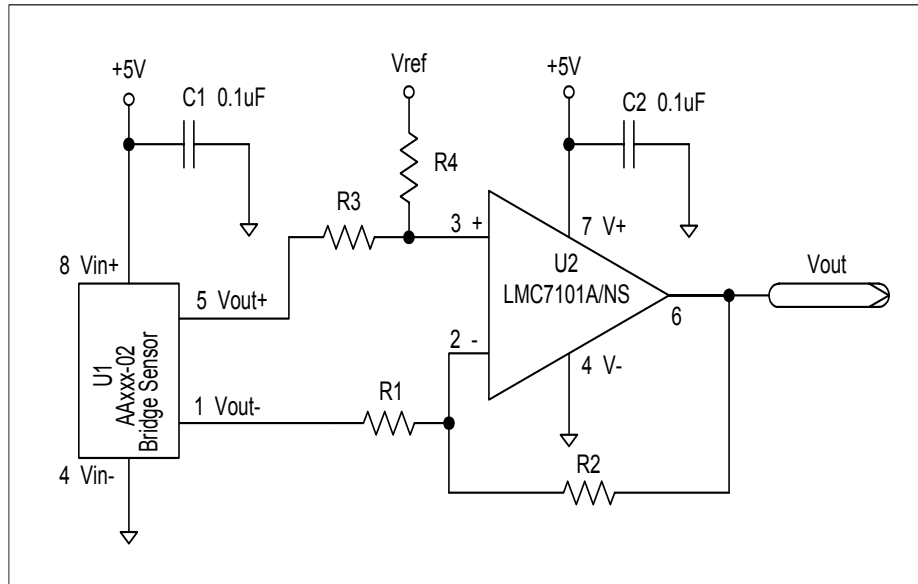

*SINGLE OP AMP PREAMPLIFIER CIRCUIT*

The equation for the amplified voltage is:

$$V_{out} = \left( (V_{out+}) \left( \frac{R_2}{R_1 + R_2} \right) \left( \frac{R_3 + R_4}{R_3} \right) - (V_{out-}) \left( \frac{R_4}{R_3} \right) \right) + V_{ref}$$

Assuming  $R_1 + R_2 = R_3 + R_4 \gg 5K$

This type of amplifier has two significant limitations in that;

1) the feedback resistors load the output of the NVE bridge sense resistors,  
and

2) the circuit has a poor common mode rejection (CMRR) if the resistor ratios are not ideally matched.

Users of this circuit should be aware of the deficiencies and ensure that the feedback resistors are large compared to the bridge resistor values and that the bridge supply is stable and free from noise and ripple. Any pickup on the bridge leads should be minimized through proper layout, filter capacitors, and/or shielding.

**Two Op Amp Bridge Amplifier**

The two op amp circuit shown below reduces the loading of the preamplifier on the NVE bridge outputs but still has a CMRR that is dependent on the ratio of resistor matching. The AC CMRR is also poor in that any delay of the common mode signal through op amp U2 provides a mismatch in the signals being delivered to op amp U3 for cancellation. Its advantages are simplicity and low cost.

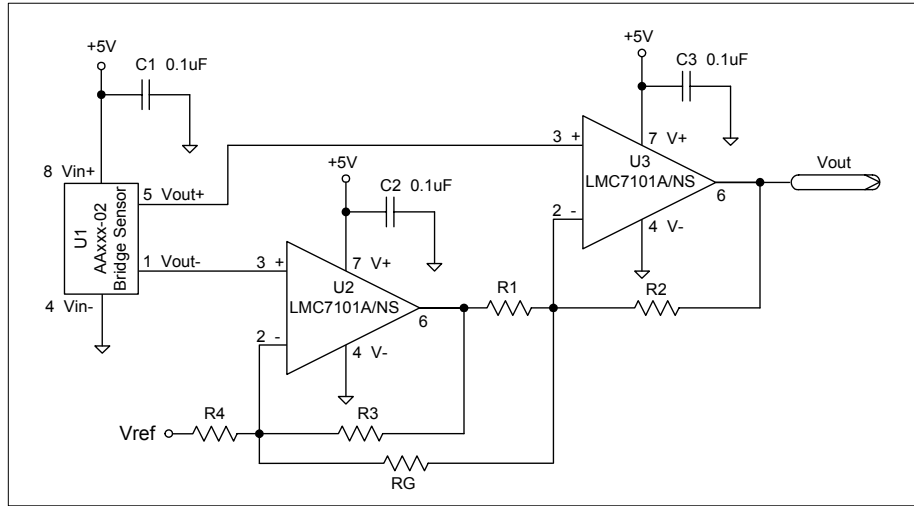

*TWO OP AMP PREAMPLIFIER CIRCUIT*

The equation for DC gain of the two op amp circuit (assuming infinite input impedance of the op amps) is:

$$V_{out} = V_{ref} + V_{IN} \left( 1 + \left( \frac{R_2}{R_1} \right) + \left( \frac{2R_2}{R_G} \right) \right) \quad \text{for} \quad \left( \frac{R_2}{R_1} \right) = \left( \frac{R_4}{R_3} \right) \quad \text{and} \quad V_{IN} = (V_{out+}) - (V_{out-})$$

**Three Op Amp Bridge Amplifier**

The three op-amp circuit shown in the figure below is the most robust version of an op amp implementation. In this circuit the CMRR still depends on the resistor ratios of the differential amplifier (U4) but is not dependent on the resistors R1, RG, and R2. Therefore to minimize common mode errors the gain of the first stage should be made large compared to the gain of the second stage. The minimum gain of the second stage is dependent on amplifiers U2 and U3 output voltage range and Op Amp U4's common-mode input range, which for the LMC7101, is rail-to-rail allowing a gain of one (1) in the second stage.

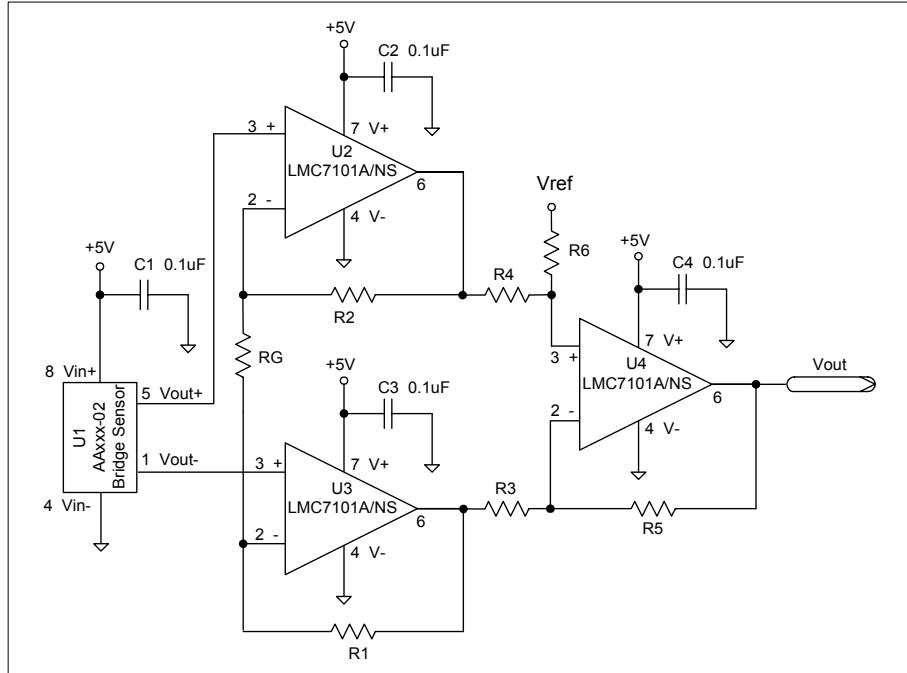

**THREE OP AMP PREAMPLIFIER CIRCUIT**

The DC transfer function of the circuit is:

$$V_{out} = V_{ref} + \left(1 + \frac{2R_1}{R_G}\right) \left(\frac{R_4}{R_3}\right) V_{IN} \quad \text{for } R_1 = R_2, R_3 = R_5, R_4 = R_6 \text{ and } V_{IN} = (V_{out+}) - (V_{out-})$$

The symmetrical nature of this configuration also allows for cancellation of common mode errors in amplifiers U2 and U3 if the errors track.

**Instrumentation Amplifier Bridge Preamplifier**

The advent of low-cost, high-performance Instrumentation Amplifier (IAs) such as the Analog Devices AD620 and the Burr Brown INA118 have greatly simplified the design of bridge preamplifiers while adding significant advantages in noise, size, and performance over op amp implementations. The figure below shows the design of a bridge amplifier circuit using an INA118 (the Analog Devices AD620 is pin-for-pin compatible with the INA118).

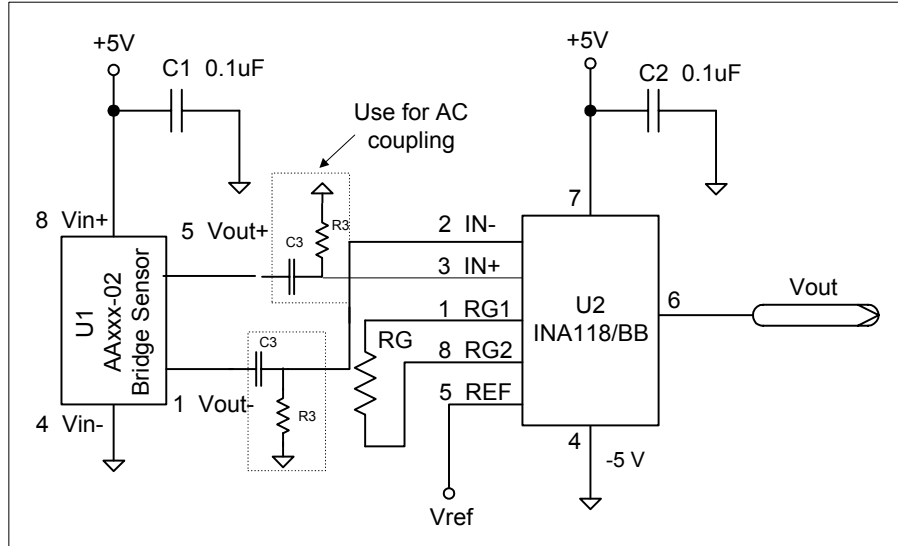

**INSTRUMENTATION AMPLIFIER PREAMPLIFIER CIRCUIT**

The gain of this circuit is:

$$V_{OUT} = \left( 1 + \frac{50K}{R_G} \right) V_{IN} + V_{ref} \quad \text{with } V_{IN} = (V_{out+}) - (V_{out-}) \text{ and the frequency 3dB}$$

point is given by  $f = \frac{1}{2\pi R_3 C_3}$

Integrated circuit instrumentation amplifiers utilize circuit techniques where resistor matching is not as critical to the CMRR as active device matching. Active device matching can be easily controlled on integrated circuits allowing for greatly improved CMRR of instrumentation amplifiers over op amp implementations. Also, the gain-bandwidth product of instrumentation amplifier circuits can be higher than op amp circuits.

**Threshold Detection Circuit**

The figure below shows the implementation of a low power threshold detection circuit that utilizes the AAxxx-02 GMR Magnetic Field Sensor and the Burr Brown INA118 instrumentation amplifier. Comparator hysteresis has been added around the LM311 comparator to minimize random triggering of the circuit on potential noise sources and pickup. The gain of the instrumentation amplifier is the same as before. The hysteresis of the comparator is approximately:

$$V_h \approx 2.5 \left( \frac{R_1}{R_1 + R_2 + R_3} - \frac{R_2}{R_1 + R_2} \right) \text{ Neglecting the finite output swing of the comparator.}$$

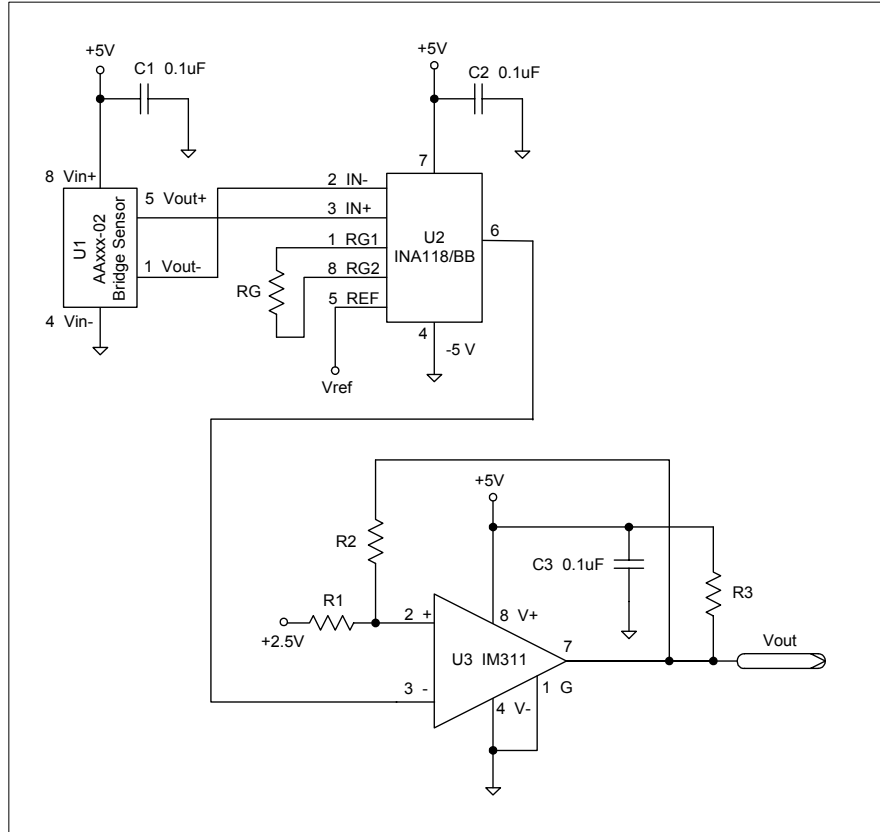

**THRESHOLD DETECTION CIRCUIT**

### Noise In NVE Giant Magnetoresistive Sensors

The 1/f noise characteristic of NVE GMR sensors is approximately an order of magnitude higher than noise for thin film resistors. The noise has been shown to follow the usual characteristics of being proportional to the square of the current density. The figure below shows a noise plot of an AA002-02 sensor using various methods for powering the sensor:

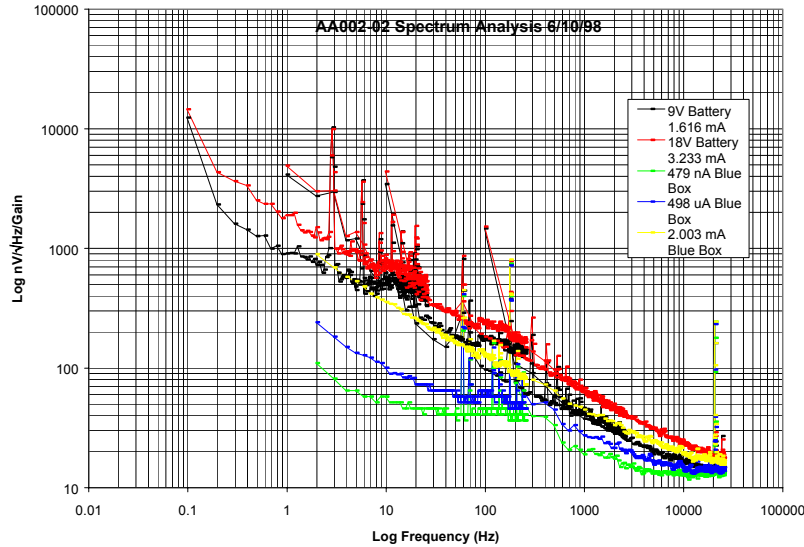

For use in low-field applications, the noise of the NVE GMR sensors limits the minimum signal detected. For measuring low fields it is recommended that an AC modulation/demodulation scheme be implemented. The figure below shows a block diagram of an AC modulation/demodulation circuit. The phase shifter block is required to account for parasitic phase shift around the loop.

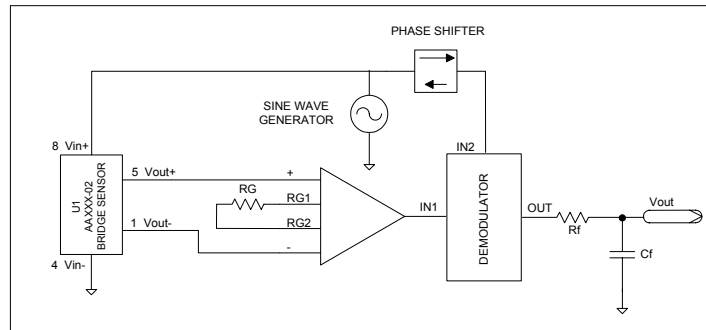

## Use Of GMR Magnetic Field Sensors

### General Considerations

All of NVE's GMR Magnetic Field sensors have a primary axis of sensitivity. The figure below shows an AAxxx-02 Series GMR Magnetic Field Sensor with a cut away view of the die orientation (not to scale) within an SOIC8 package.

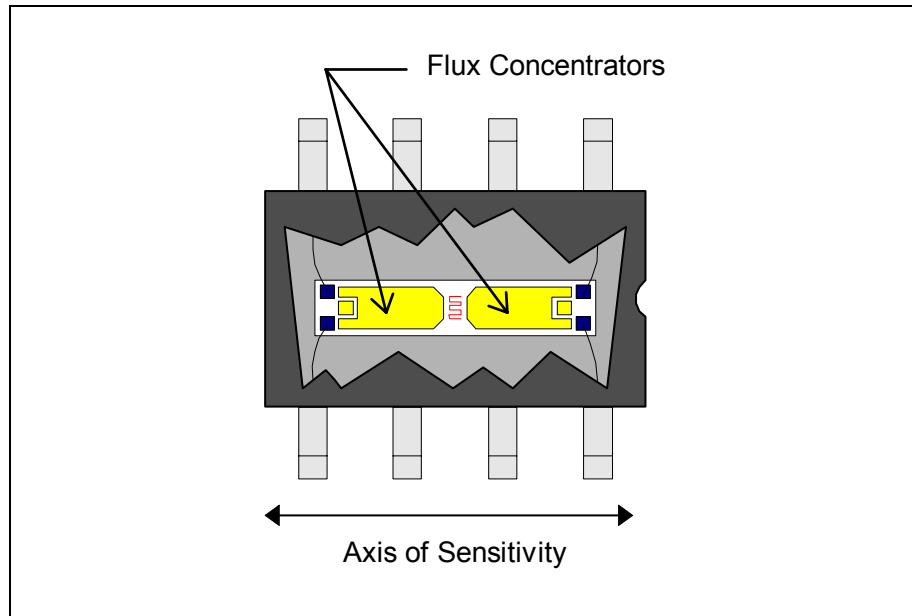

*SENSITIVE MAGNETIC AXIS – AA00X-02 SENSOR*

The flux concentrators on the sensor die gather the magnetic flux along the axis shown and focus it at the GMR bridge resistors in the center of the die. The sensor will have the largest output signal when the magnetic field of interest is parallel to the flux concentrator axis. For this reason, care should be taken when positioning the sensor to optimize performance. Although sensor position tolerance may not be critical in gross field measurement, small positional variation can introduce undesirable output signal errors in certain applications.

## Magnetic Biasing

In many applications, GMR Magnetic Field Sensors make use of biasing magnetic fields. Biasing magnetic fields provide either a magnetic field to sense (where one is not present) or create a pseudo zero field. Back-biasing a sensor consists of applying a magnetic field through the sensor package without influencing the sensor. The purpose is to create a magnetic field that the device can sense for applications where no magnetic field is present such as ferrous material detection. The figure below shows a permanent magnet used for this purpose. The magnet adjusted in the X direction, as shown, achieves the maximum field in the Z direction and minimum field in the sensitive X direction.

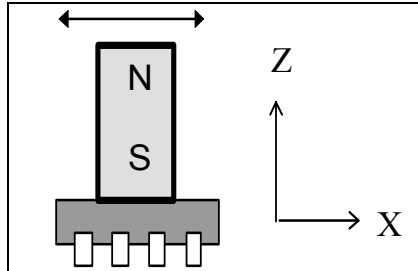

### MAGNETIC BIASING CONFIGURATION

Another means of biasing a GMR Magnetic Field Sensor is to provide a constant magnetic field in the sensitive direction. The result is a sensor biased part way up its output curve shown in the figure below.

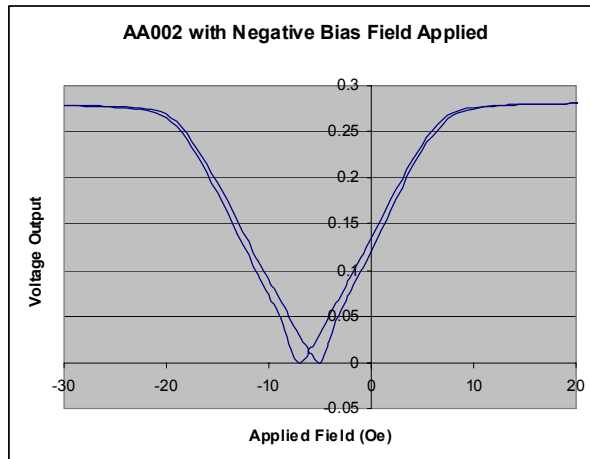

This biasing technique creates a bipolar output with a DC offset. Another typical purpose for this kind of biasing is to bias the sensor away from the zero field area, where hysteresis is more pronounced.

Since gradiometers respond to the flux gradient rather than the field itself, they can be biased to zero offset to work in a gear tooth sensing application. It is important not to bias a gradiometer to a high enough field to saturate the GMR resistors.

More information on biasing gradiometers for gear tooth sensor applications is found in the GT Sensor application notes section.

## Application Notes for GT Sensors

### General Theory of Operation of Differential Sensors (Gradiometers)

Differential sensors, or gradiometers, provide an output signal by sensing the gradient of the magnetic field across the sensor IC. For example, a typical GMR sensor of this type will have four resistive sensor elements on the IC, two on the left side of the IC, and two on the right. These resistive sensor elements will be wired together in a Wheatstone bridge configuration. When a magnetic field approaches the sensor IC from the right, the right two resistive sensor elements will decrease in resistance before the elements on the left. This leads to an imbalance condition in the bridge, providing a signal output from the bridge terminals.

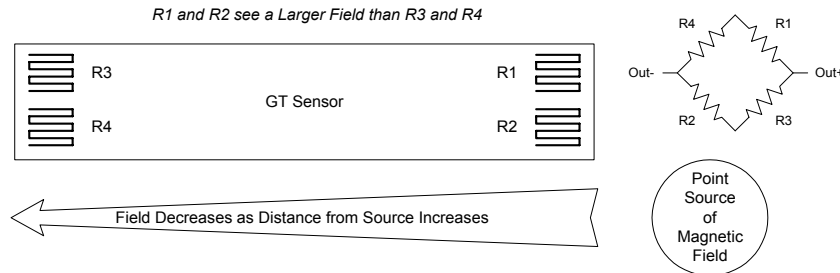

Note that if a uniform magnetic field is applied to the sensor IC, all the resistive sensor elements will change at the same time and the same amount, thus leading to no signal output from the bridge terminals. Therefore, a differential sensor cannot be used as a magnetometer or an absolute field detector; it must be used to detect the presence of a magnetic gradient field.

Gradient fields are present at the edge of magnetic encoders and magnetically biased gear teeth. As a result, differential sensor elements are ideally suited for speed and position detection in these applications.

### GT Sensor Operation with Permanent Magnet Bias

Magnetic encoders generate their own magnetic field, but a gear tooth wheel does not, so if a differential sensor is to be used to detect gear teeth, a permanent magnet is required to generate a magnetic bias field. The differential magnetic sensor will then be used to detect variations in the field of the permanent magnet as the gear tooth passes by in close proximity.

The following series of drawings shows a biased GT Sensor. The drawings show how the magnetic field generated by the bias magnet is influenced by the moving gear tooth, and how the output signal appears at four equally spaced positions between adjacent gear teeth:

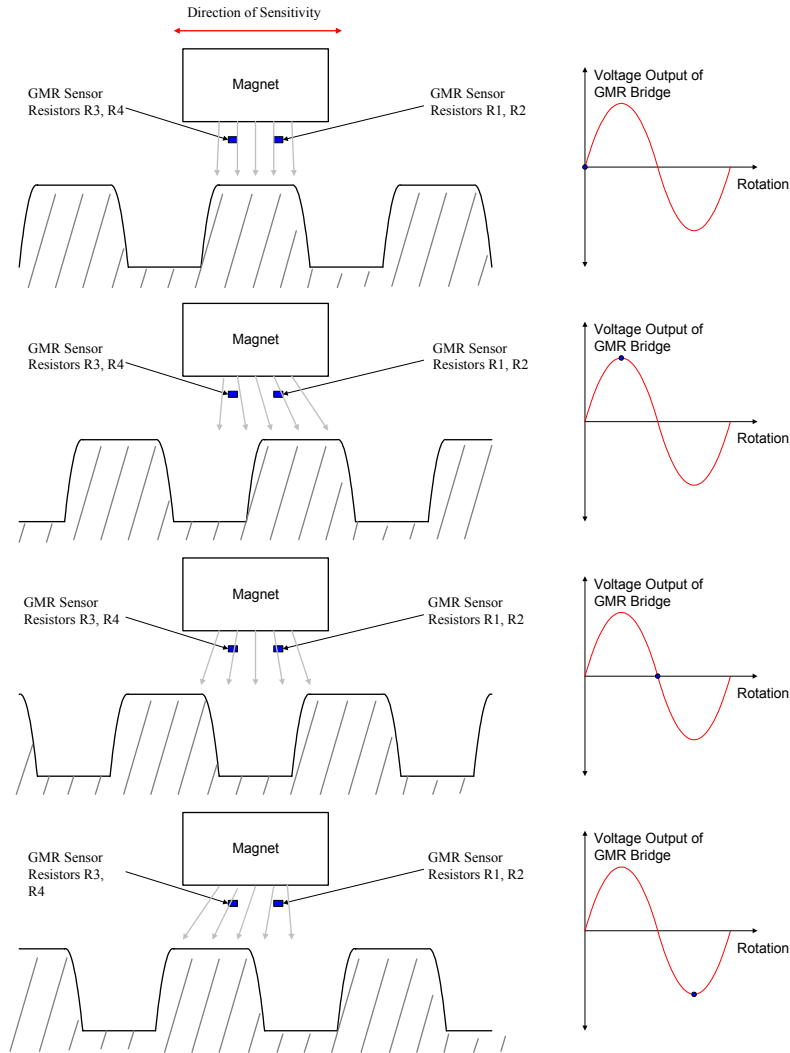

Despite the simplicity of the preceding drawings, magnetically biasing a gear tooth for a production product can be complex. Typically, the position of the sensor relative to the magnet is fixed, but there is a variation in the airgap between the sensor and the target gear tooth. This can lead to magnetic conditions that can cause an unstable output.

For example, tolerances on the placement of the magnet relative to the sensor are not perfect, and any slight variation in the placement of the magnet can lead to offset problems; see the drawing below:

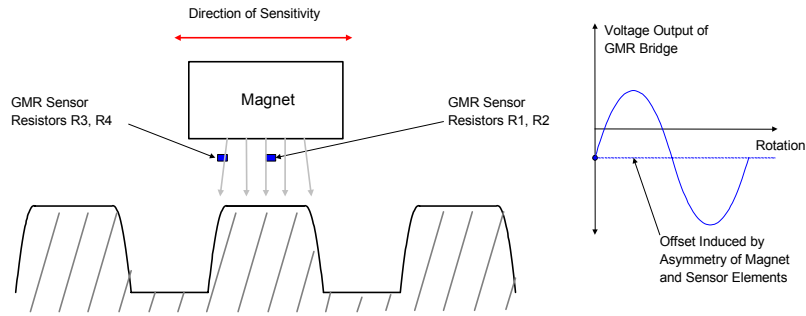

Generally the magnet is glued in place; this can lead to tilting of the magnet with respect to the sensor, introducing more variations in the field at the sensor, and more offset problems, as well as potential glue joint problems. Furthermore, the composition of most inexpensive magnets is not particularly uniform, and many have cracks or other mechanical imperfections on the surface or internally that lead to a non-uniform field. Most permanent magnets have a temperature coefficient, and some can lose up to 50% of their room temperature strength at 125°C. The following drawing shows the effects of temperature added onto an imperfect bias. The offset of the sensor varies with temperature as shown:

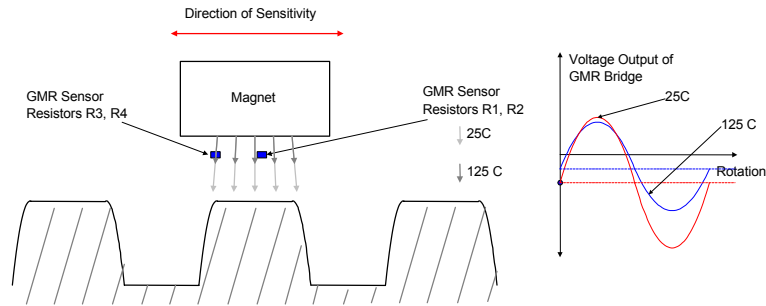

Finally, as the airgap changes, the magnetic field at the sensor also changes. So, the magnetic field at the sensor will vary from one installation to the next, and if the gear has runout, wobble, or expands with temperature, the output signal and offset of the sensor element will vary.

As a solution to these potential problems, NVE's AKL-Series GT Sensors offer internal signal processing which compensates for temperature variation, sensor output variation, and magnet/target variation. This results in a stable digital output signal with wide tolerance for magnet placement and quality. For analog applications, NVE offers the following guidelines for biasing GT Sensors with permanent magnets:

1. NVE recommends about 1.5 mm distance from the back of the sensor to the face of the magnet, in order to keep the flux lines at the sensor element "flexible" and able to follow the gear teeth with relative freedom. This distance can be achieved by putting the sensor on one side of a circuit board, and the magnet on the other.
2. To fix the position of the magnet on the circuit board more precisely, the board can be made thicker, and a pocket can be machined into it to hold the magnet. This service is readily available from most circuit board manufacturers.
3. Various high temperature epoxies can be used to glue the magnet in position; NVE recommends 3M products for this purpose.
4. If zero speed operation is not required, AC coupling the sensor to any amplifier circuitry will remove the offset induced in the sensor by the magnet.
5. If zero speed operation is required, some method of zeroing the magnet-induced offset voltage from the sensor will be required for maximum airgap performance. NVE's AKL-Series sensors have this feature built in, and NVE's DD001-12 signal conditioning IC also includes this feature.
6. GT Sensor ICs are centered in the plastic package, so placement of the permanent magnet should be symmetrical with the package.
7. Ceramic 8 magnets are a popular choice in this application, and provide good field characteristics and low cost. However, C8 magnets lose substantial magnetic strength at higher temperatures. For analog output applications where a consistent signal size over temperature is desirable, use of an Alnico 8 magnet (the most temperature stable magnet) is recommended. Samarium-Cobalt magnets and Neodymium-Iron-Boron magnets are not recommended because they are so strong that they tend to saturate the GMR sensor element.

## GT Sensor Operation with Magnetic Encoders

Magnetic encoders generate their own magnetic field, so they are much easier to work with than gear tooth wheels, as no bias magnet is required for the sensor. Also, magnetic encoders have alternating north and south magnetic poles on their faces. Therefore the magnetic field is generated by the moving body, and sensor offset problems are greatly reduced. The following drawing shows a GT Sensor response to a magnetic encoder:

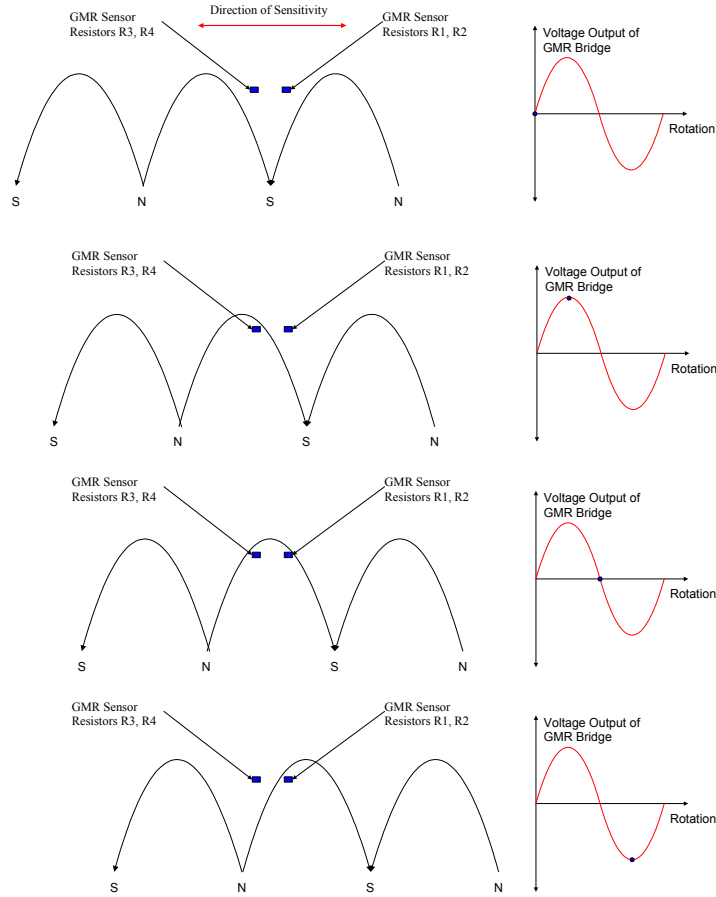

Note that in this case, as long as the sensor is positioned symmetrically with the encoder, offset is minimized. Also note that the GT Sensor provides one full sine wave output for each magnetic pole. This is double the frequency of a Hall effect sensor, which provides one full sine wave output for each north-south pole pair. As a result, replacing a Hall sensor with a GT sensor doubles the resolution of the output signal.

NVE offers the following guidelines for using GT Sensors in magnetic encoder applications:

1. Position the sensor as symmetrically as possible with the encoder to minimize offset problems.
2. AC couple the sensor to an amplifier to eliminate any offset issues if zero speed operation is not required.
3. If zero speed operation is required, NVE's AKL-Series and DD-Series parts automatically compensate for offset variations and provide a digital output signal.

## Application Circuits

Signal processing circuitry for analog output sensors, such as NVE's ABL-Series products, varies widely in cost, complexity, and capability. Depending on user requirements, a single op amp design may be sufficient. For low signal level detection, a low noise instrumentation amp may be desirable. For complete control of all parameters, use of a complete signal processing IC which can tailor gain, offset calibration, and temperature compensation may be required. Please see NVE's Engineering and Application Notes bulletin for further details on the various approaches that are available.

For digital output applications, NVE's AKL-Series and DD-Series products provide the most cost effective approach. Both of these products provide two-wire, *i.e.*, current modulated output signals. For many applications, an open collector or digital voltage output signal is desirable. The following two circuits convert a two-wire current modulated signal into an open collector or digital voltage output signal:

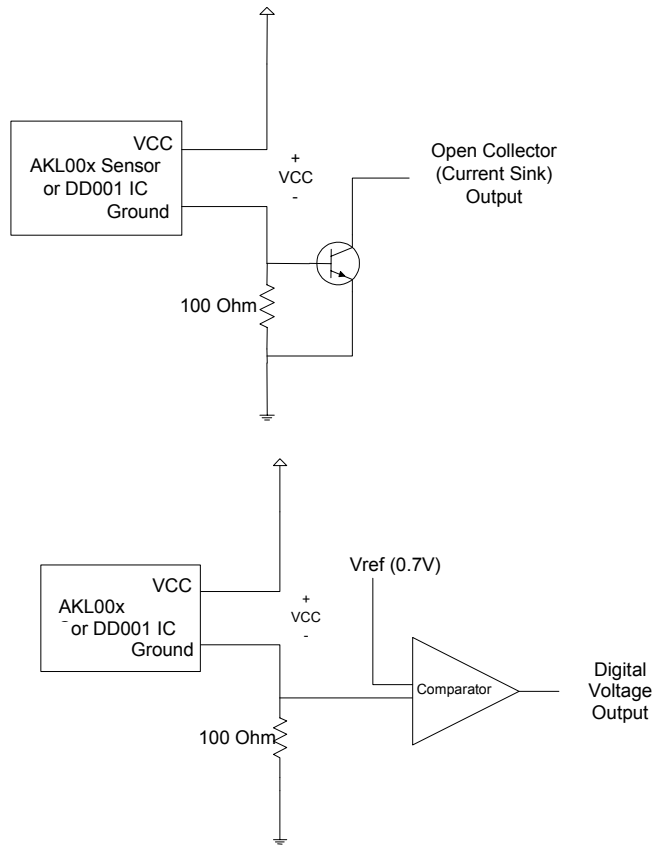

## Measuring Displacement

### Basic concepts

Because of their high sensitivity, GMR Magnetic Field Sensors can effectively provide positional information of actuating components in machinery, proximity detectors, and linear position transducers. The figures below illustrate two simple sensor/permanent magnet configurations used to measure linear displacement. In the first diagram, displacement along the  $y$ -axis varies the  $B_x$  field magnitude detected by the sensor that has its sensitive plane lying along the  $x$ -axis. The second diagram has the direction of displacement and the sensitive plane along the  $x$ -axis.

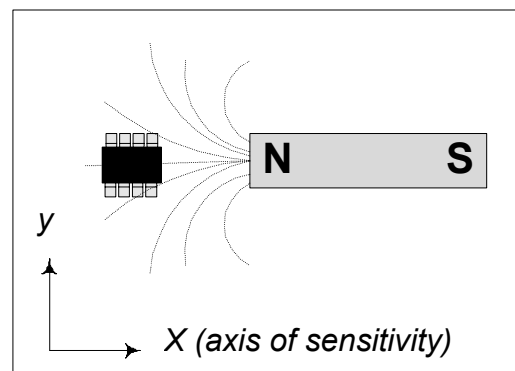
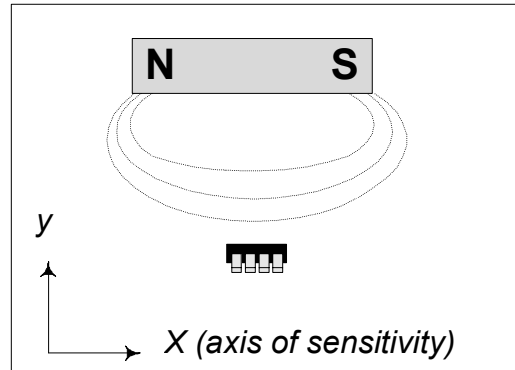

### Application examples

- Hydraulic/pneumatic pressure cylinder stroke position
- Suspension position
- Fluid level
- Machine tool slide position
- Aircraft control-surface position
- Vehicle detection

**Current Measurement**

**Basic concepts**

GMR Magnetic Field Sensors can effectively sense the magnetic field generated by a current. The figure below illustrates the sensor package orientation for detecting the field from a current-carrying wire. This application allows for current measurement without breaking or interfering with the circuit of interest. The wire can be located above or below the chip, as long as it is oriented perpendicular to the sensitive axis.

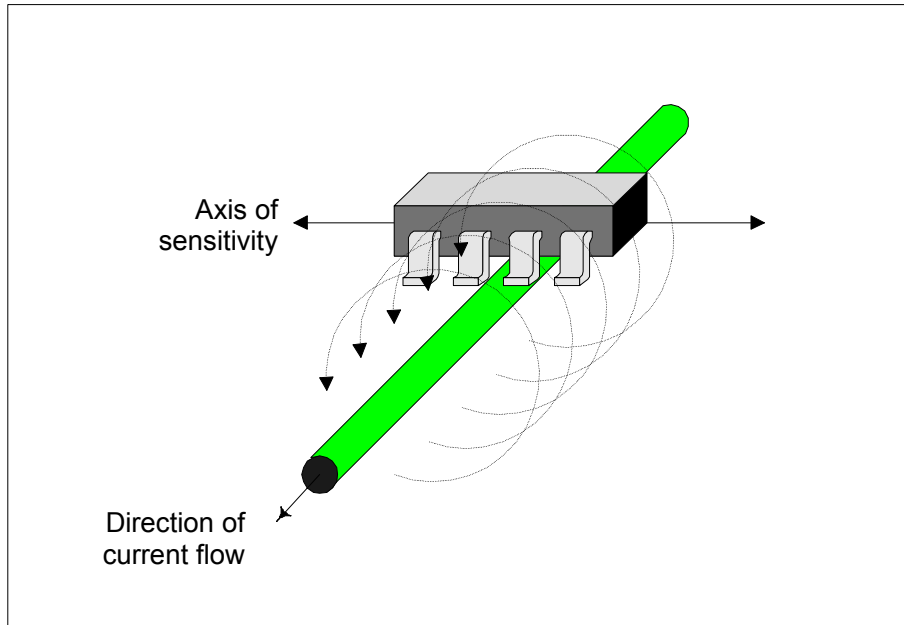

*SENSING MAGNETIC FIELD FROM A CURRENT-CARRYING WIRE*

The figure below shows another configuration where a current trace on a PCB is under the board-mounted sensor.

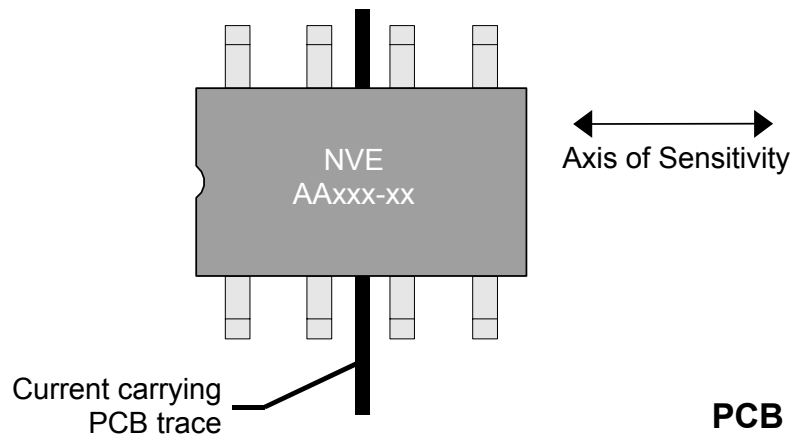

### *SENSING MAGNETIC FIELD FROM A CURRENT CARRYING PCB TRACE*

An Excel spreadsheet is available on NVE's web site which helps calculate the magnetic field at the sensor from a current carrying trace on the board as shown in the diagram above.

#### **Principles of Operation**

The magnetic field created by the current surrounds the conductor radially. As the magnetic field affects the GMR material in the sensor, a differential output is produced at the out pins of the sensor. The magnetic field strength is directly proportional to the current flowing through the conductor. As the current increases, the surrounding magnetic field will also increase, thus increasing the output from the sensor. Similarly, as the current decreases, the magnetic field and sensor output decrease.

Since the current is not measured directly, the sensor output must be correlated to the current. The following data and graphs are based upon analysis of NVE's evaluation board contained in our current sensor evaluation kit, part number AG003-01. The PCB contains four traces of three different widths: 90 mils, 60 mils, and 10 mils.

**DATA ANALYSIS- One To Ten Amps**

Currents (1-10 A) were run through the 90 and 60-mil traces found on the PCB in NVE's Current Sensor Evaluation Kit AG003-01. An AA003-02 sensor was placed over the 90 and 60-mil traces and different levels of DC current were run through the traces. This current and the corresponding output from the sensors are shown in the following graphs.

**AA003-02 over 0.090" wide,  
0.0023" thick trace**

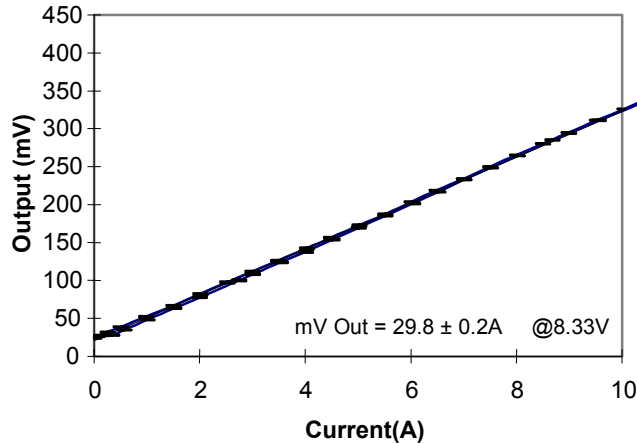

The sensor was supplied with 8.33V and was hand-soldered over the trace. The trace is 0.090" wide and 0.0023 ± 0.0002" thick. The marks on the graph are output error bars which cover the expected error from this part due to intrinsic hysteresis and measurement errors. The current was swept from zero to ten Amps and back to zero multiple times. The output voltage at specific current levels was analyzed and an output voltage precision was determined to have a relative error of approximately ±0.7% with errors of up to 2% possible at low currents.

A linear fit on the data above shows a 29.8 ± 0.2 mV/A correlation in this configuration. The sensor utilizes a Wheatstone bridge and thus the applied voltage across the bridge is directly related to the output. By dividing the slope by 8.33V, we get a more useful number of 3.57 ± 0.02 mV/V/A. With this number, the user can determine the expected output for any applied voltage.

The same analysis was given to a 0.060" wide trace of the same thickness. A voltage of 8.33V was applied and the resulting graph is shown below.

**AA003-02 over 0.060" wide  
0.0023" thick trace**

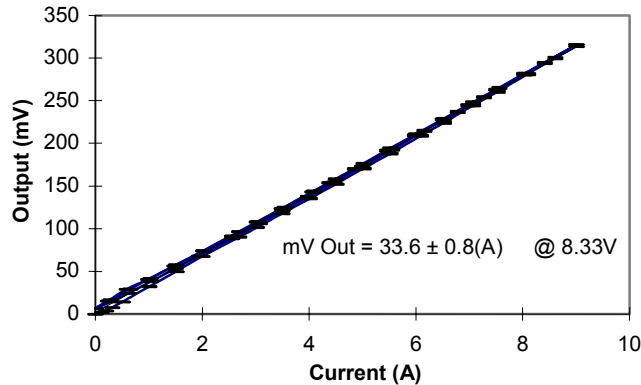

The current in this trace was swept from zero to nine Amps, similarly to the 90-mil analysis. The sensor output to current correlation from this graph is  $4.0 \pm 0.1$  mV/V/A. The differences between the 90 and 60-mil traces is due to the field distribution/density differences between the two due to the difference in width.

### **Resolution**

The resolution of the sensor is a function of environmental electromagnetic noise, intrinsic noise, and hysteresis. In most applications, the environmental noise is the limiting factor in resolution. Data and information in this section are based upon non-filtered, non-amplified, non-shielded output. In this “raw” configuration, a resolution of better than 1 mA was found. With proper filtering, amplifying and shielding, the noise level can be decreased and thus the usable resolution will increase.

### **Hysteresis and Repeatability in GMR Current Sensors**

All magnetic materials have an effect called magnetic hysteresis. This hysteresis contributes greatly to the error values given above. Hysteresis also creates a potential that the same current can produce two different voltage outputs. The hysteresis, and thus the error, is largest when the current changes direction. If the current changes direction, the precision of the output at low currents decreases significantly. The specified error of 0.7% will not be obtained again until the current goes above approximately 2A. This guideline is very rough as applications vary.

Another magnetic contribution to the error can be overcome by an initialization current. Often, depending on the magnetic history (hysteresis) of the sensor, the initial outputs are different from subsequent outputs as seen in the figure below:

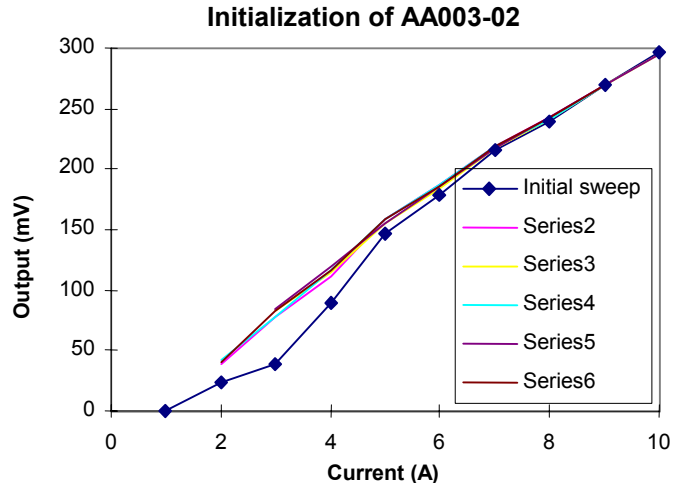

The initial sweep data has deviated from the other series of current sweeps. After the first sweep was completed, the subsequent five sweeps fell right on each other. This shows that a lower error can be obtained by “initializing” the sensor. After initialization, the error will be much lower until the working current range is exceeded in either direction. Saturation of the device (currents in the 20A range) as well as changing the applied current direction will increase the hysteresis/error.

For currents of approximately 2 Amps and smaller, the output repeatability is nominally 2% while higher currents produce output repeatability errors of less than 1%. Low current measurements of an initial current sweep may exceed 15% error in repeatability.

**DATA ANALYSIS- Low Current Sensing**

The low current analysis is handled here separately from the higher current analysis due to special considerations that must be made, although much of the same hysteresis and resolution considerations from high field sensing apply here. For low current sensing, two configurations of 0.010" wide traces were used. The first analysis will be with an AA003-02 sensor over a single 10-mil trace and the second analysis will consist of an AA003-02 sensor over seven 10-mil traces. With these traces, milliamp and sub-milliamp currents are of interest. Due to the hysteresis at low currents as discussed above, a biasing magnet was used to set the parts to approximately half of their linear range, or approximately 20 mV/V. This bias point can be seen as the Y intercept in the figures below. In this way, the output will not be near the natural zero current range, and thus, repeatability is increased. With this configuration an alternating sense current will produce a bipolar output with a DC offset in an AC application.

Note that although a permanent magnet was used for biasing in these experiments, a better method is to use a constant current. The current can be run on a trace parallel to the trace to be sensed, and will add to the current of interest. The magnetic field from the bias current can be more closely controlled than the field from a permanent magnet, which varies substantially with distance from the sensor. In addition, provided the bias current is stable over temperature, the bias field at the sensor element will also be stable over temperature. Permanent magnets often have large temperature coefficients, leading to biasing changes with temperature.

**AA003-02 over single 0.010" wide  
0.0023" thick trace**

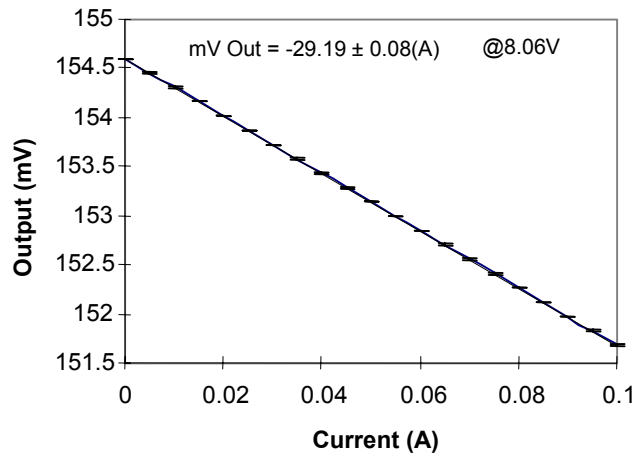

The sensor that was used to take this data was supplied with 8.06V. The marks on the graph are output error bars that cover the expected error from this part due to the part's intrinsic hysteresis and measurement errors. The current was swept from zero to 100 mA and back to zero multiple times. In this biased state, the sensor is extremely linear and hysteresis is low. A weighed linear fit shows a  $-29.19 \pm 0.08$  mV/A correlation with 8.06V supplied which results in a sensitivity of  $3.70 \pm 0.01$  mV/V/A.

The same analysis was performed on the seven 0.010" wide traces of the same thickness. A voltage of 8.06V was again applied and the resulting graph is shown below in the figure below.

**AA003-02 over seven 0.010" wide  
0.0023" thick traces**

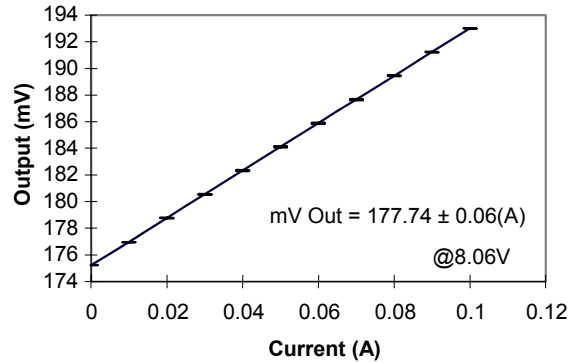

Seven traces were run under the part so that the magnetic fields from the seven traces are additive at the sensor thus getting a much higher output with less applied current. To a first-order approximation, theory predicts that the field will be increased seven fold from just a single trace. The sensitivity from the single trace above is 3.7 mV/V/A; seven times this is 25.9 mV/V/A, which is not quite achieved. This discrepancy is due to the different current distributions. The loss would not be as extreme if seven times the current went through the single trace.

### **Resolution**

Resolution is a function of environmental noise. By shielding, amplifying, and filtering, the low limit and usable resolution can be greatly increased. The data for the analysis done here was with a “raw” setup, no amplification or filtering. In a zero gauss chamber, single microamps were detected but the measurement equipment limited any in-depth analysis.

### **Effects of Biasing**

For the analysis done above, a small ceramic magnet was used to supply a magnetic bias field in a direction which is parallel to the sensitive axis of the sensor. This magnetic bias “pushes” the output to a certain value, which is now a “psuedo zero” field point. The magnetic field from a current carrying conductor is also directional. If a current flows in such a direction as to add to the biasing field, the output from the sensor will increase. Likewise, if a current flows in the opposite direction, its resultant field will subtract from the biasing field, and the output will decrease. This directionality can be seen by looking at the output slopes of the previous two graphs. In the first graph, the output displayed shows the current produced a field opposite to the biasing magnetic field. Thus showing as the current increases, the output of the sensor decreases. In the same respect, the second graph shows that the field from the current was in the same direction as the biasing field.

## **Offset Characteristics**

When using the specified sensitivity to predict the output of a sensor, remember that the sensor typically has a DC offset voltage. This is due to electrical bridge imbalance as well as external magnetic field bias (earth's field, magnets...). The output of the sensor without applying the current of interest is the base line output. The effects of the current will be added to this base line value. For the graphs shown on pages 130 and 131, the Y axis intercept is the base line offset. To determine the output of the sensor for a given field, this Y intercept number must be added to the value obtained by multiplying the current value by the slope.

## **AC**

As mentioned previously, most information thus far has focused on DC applications. AC current detection with an AA003-02 is unique and thus deserves special attention in a separate application. Because the sensor is magnetically omni-polar, the output will be the same sign for either direction of magnetic field. As an AC current changes direction, the field surrounding the conductor will also change direction. The sensor's output will produce a fully rectified output. Low current AC is particularly laden with hysteretic errors. One method of creating both a bipolar output and a lower error is to magnetically bias the sensor. Biasing is discussed above in this Engineering and Application Notes booklet.

## **Part-to-Part Sensitivity**

The data and evaluation thus far have focused on individual part performance. The part-to-part performance will also be briefly examined here. Each current sensor is tested and sorted to be within certain limits as given in the specification sections of this catalog. The main specification that affects the output of the sensor is the sensitivity. The AA003-02 sensors are tested to a sensitivity range of 2.0 to 3.2 mV/V/Oe. The offset specification also affects the output. The offset is the zero current or electrical imbalance of the Wheatstone bridge inside the sensor.

The magnetic field of the earth at NVE, is approximately 0.5G at a 70-degree angle to the horizon (values will vary depending on geographical location). The effects of this magnetic field should be analyzed in each application.

Care should be taken by the user to reduce the number and proximity of ferrous materials and magnetic field producers around the sensor. This typically is not a concern, but in some highly populated boards, this may be a necessity. Close proximity to such devices can increase the magnetic hysteresis or affect the output. In turn, these devices will decrease the sensor's output precision.

The output of the AA003-02 is functionally dependent on the distance between the sensor and the current. The field from a current carrying conductor is inversely proportional to the distance from the conductor. As the distance from the sensor to the conductor increases, the output from the sensor decreases. Likewise, as the sensor moves closer to the conductor, the output will increase. For the data analysis done in this report, the sensor was placed "live bug" over the current traces. In this configuration, the actual sensor element is about 0.04" from the top of the PCB trace. The output will increase with the current carrying conductor placed directly over-top of the sensor package. In this configuration, the sensing element is approximately 0.02" from the surface of the conductor. This distance change will account for an estimated doubling of sensor output.

**Current Sensing - Detailed Considerations**

Care must be taken in interpreting the output waveform when using GMR as current sensors. GMR sensors function as omnipolar sensors by producing positive output regardless of the magnetic field direction. In the case of AC excitation, the bipolar field created by a sinusoidal AC current will produce an output that will look like a full-wave rectified sinusoidal waveform. Biasing the sensor partway up the curve will restore a sinusoidal output with a DC component.

Although most of the examples given in this section use the AA003-02 sensor element, any of NVE's AA-Series, AAH-Series, or AAL-Series analog sensors will function as a current sensor as described above. The customer can select from a wide range of magnetic sensitivities in order to have the best sensing characteristics for the current range to be detected.

**Current Sensing Application Examples**

- Non-intrusive AC or DC current detection or sensing
- PCB mounted current detection or sensing (PCB trace or strap current carrier)
- Toroidal Hall effect current detector or sensor replacements
- Industrial instrumentation
- Industrial process control
- Current probes

NVE has a current sensor evaluation kit, AG003-01, which has a variety of different size traces complete with on-board sensors, available directly or through our distributors.

## Magnetic Media Detection

### General discussion

GMR Magnetic Field Sensors can be used for detecting different types of magnetic media. In this situation, NVE defines magnetic media as material that has a distinct magnetic signature. The media is typically a non-magnetic substrate with magnetic material placed in or on the substrate. Typically, GMR sensors are used to “read” the magnetic signature by sweeping the substrate and the sensor past each other.

Depending upon the application, the magnetic parts of the substrate can be detected indirectly by sensing a perturbation of an externally applied field or sensed directly due to the part’s own field. The output of the sensor will be a function of: (1) the magnetic properties of the media; (2) the working gap; and (3) the type of sensor used.

### Application examples

- Magnetic ink detection
- Magnetic stripe reading
- Fine magnetic particle detection
- Media magnetic signature detection
- Magnetic anomaly detection in substrates

### Basic concepts

For applications in which minimum size is not critical, external flux concentrators can be used to increase sensor sensitivity. These external flux concentrators function in the same manner as the flux concentrators within the sensor.

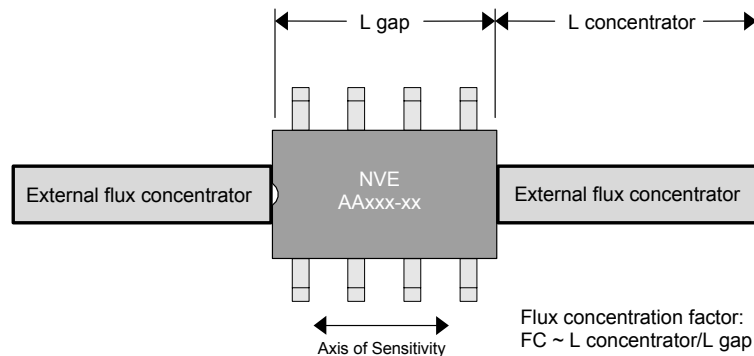

Elongated pieces of soft magnetic material gather external magnetic flux and expose the sensor to a magnetic field that is larger than the external magnetic field. For best results, two pieces of soft magnetic material of the same size are used. The concentration factor is approximately the ratio of one

flux concentrator's length to the gap between the two flux concentrators. The long dimension of the flux concentrators should be aligned with the sensitive axis of the NVE sensor. To minimize the gap, the flux concentrators should butt up against the NVE sensor package.

Since the effective permeability of the flux concentrators is equal to the concentration factor, material with permeability 100 or more times the concentration factor, will be more than sufficient. Hot rolled iron wire or even cut off iron nails will work. Flux concentrators can be round or rectangular in cross section for mounting considerations. The NVE sensor must be centered within the flux concentrators' cross sectional area. The diameter of the flux concentrators should be an appreciable fraction of the gap length or flux spreading in the gap will reduce the concentration factor. The flux concentration achieved will depend on all dimensions. However, it will depend primarily on the ratio of the concentrator length to gap. The best calculation, however, is an experimental measurement made with an actual sensor and flux concentrators. For prototyping and production, the external flux concentrator can be placed down on the PCB or other substrate. The top of the metal strip must be at least as high as the sensor package to be truly effective.

It should be noted that a flux concentrator that increases the sensitivity of a GMR sensor by a factor of five will also reduce the maximum field to which the sensor can respond to one-fifth its original value.

## Currency Detection and Validation

Currency detection and validation is a very important application of magnetic media detection. NVE's sensors have been used for detecting the magnetic material in paper bills. This magnetic material can be modeled as very small bar magnets. The magnetic field emitted by the bar magnets has two detectable orientations. The first is the vertical (radial) component of the field, and second is the horizontal (axial) component of the field. The sensitive axis of the sensor should be parallel with the component of field desired, *i.e.*, the horizontal axis, to pickup the horizontal component of the field.

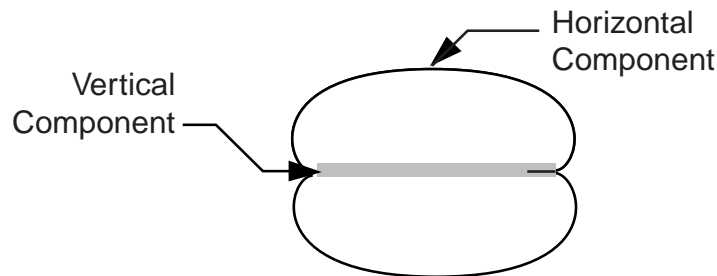

The magnetic particles in the ink of most currencies, and also any magnetic stripes on the currency, can be magnetized and demagnetized by an external field. With only the earth's field present, the bill's magnetic properties can be seen. However, the signal increases when using an external field.

This external magnetic field can be set up in a few different orientations, either in a front/back biasing configuration or positioned "upstream" of the sensor. The back biasing configuration typically consists of an electro/permanent magnet glued to the under side of the sensor or to the under side of the PCB. The magnet should be aligned to produce the minimum output from the sensor. The ferromagnetic particles in the bill will magnetize and thus distort the field to produce a field in the sensitive direction at the sensor. Front biasing works in much the same manner except in this case the source of external field is coming from the other side of the bill.

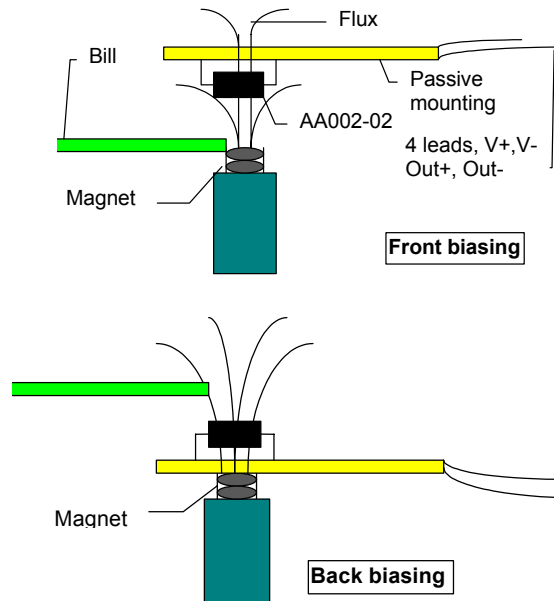

Positioning the magnet "upstream" from the sensor consists of magnetizing the bill before it reaches the sensor—this terminology comes from an application where the bills are moving past the sensor on a conveyer belt or rollers. With a magnet placed near the moving bill, the bill is magnetized before passing the sensor. The application's geometrical requirements, strength of magnet, as well as sensor-bill distance will determine which configuration works the best in each application. The following are some graphs that show the characteristics of back-biasing an AA002 sensor.

To determine the sensitivity of back biasing positioning, the magnet was moved along the sensors sensitive axis. The goal was to position the magnet so that there is minimum field in the sensitive direction. To obtain this, one pole of the magnet must be directly under the sensing resistors of the bridge. Note the steep slope around the zero output, which makes exact positioning difficult.

**Characteristic of magnet moving in sensitive direction**

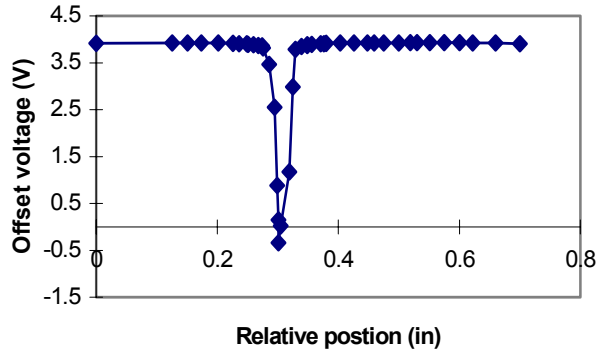

The graph below shows the variation in signal at the sensor as the currency is moved farther away from the GMR sensor element. Close proximity to the sensor is important in order to maximize output signal from the sensor.

**Characteristic of moving sensor further from bill**

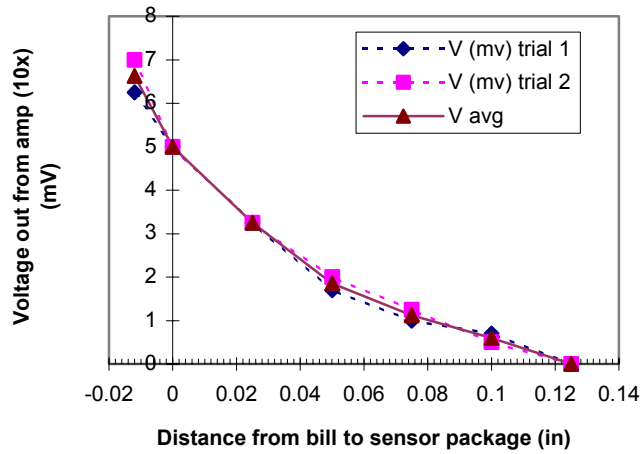

In most currency detection applications, the signal from the bill is so small that it requires AC coupling the sensor to a high gain low noise amplifier in order to get usable signal levels.

In order to achieve the highest possible signal, NVE's most sensitive sensors are necessary. NVE's AA002-02, AAH002-02, and AAL002-02 sensors are recommended. These parts utilize large flux concentrators for high sensitivity. These flux concentrators also contribute to the magnetic hysteresis of the sensor. The hysteresis shows up mainly in a changing DC offset of the part. By AC coupling the output of the sensor, the changes in magnetic field are seen at the output rather than the DC offset. Another feature of AC coupling is a consistent output independent of the sensor's orientation with respect to the earth's field. The device is sensitive enough to pick up the earth's DC field. By AC coupling, the DC offset contributed by the earth's field, is not seen at the output.

Bipolar output signals are often very useful in currency detection and other magnetic media detection applications. As a result, NVE recommends biasing the sensors in these applications by using a current strap under the sensor to carry a bias current, and therefore bias the sensor higher, on its magnetic operating characteristic.

Magnetic media detection and validation is an important and fast-growing application for magnetic sensors. NVE's sensors provide a reliable, non-contact, static or dynamic detection of the magnetic ink on paper currency. NVE's AA002 sensor can resolve the distinct features printed on U.S. and other currency. NVE's magnetic field sensors have been used for counterfeit detection, sorting, and simple bill presence detection.

**Appendix**

**Package Drawings and Specifications**

**Package Drawing – SOIC8**

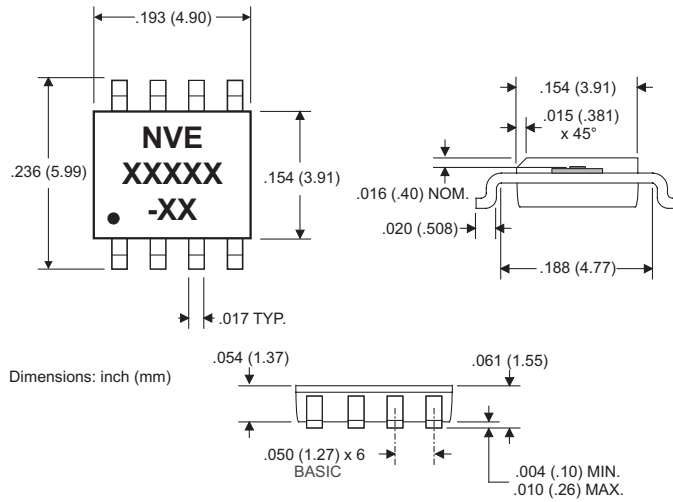

**Note:** SOIC8 Package has thermal power dissipation of 240°C/Watt in free air. Attaching the package to a circuit board improves thermal performance.

**Package Drawing – MSOP8**

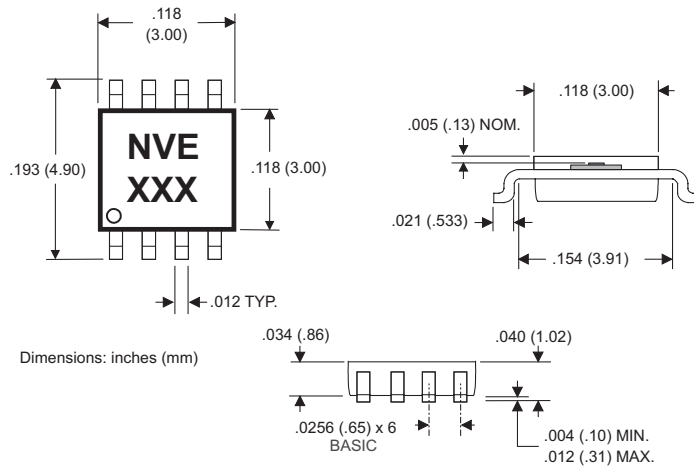

**Note:** MSOP8 Package has thermal power dissipation of 320°C/Watt in free air. Attaching the package to a circuit board improves thermal performance.

**Package Drawing – TDFN6 2.5 mm x 2.5 mm**

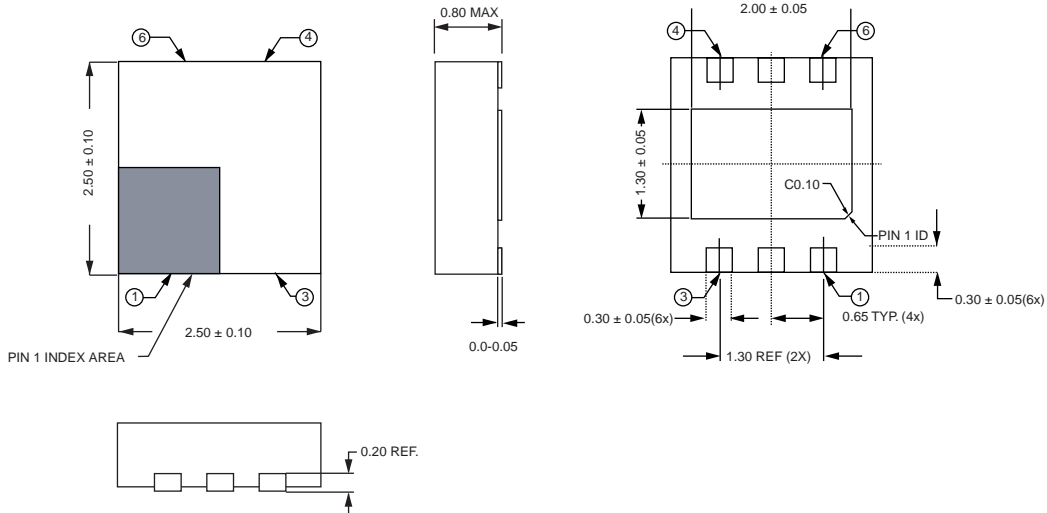

**Note: Dimensions in mm. TDFN6 package has thermal power dissipation of 320°C/Watt in free air. Attaching the package to a circuit board improves thermal performance.**

**Package Drawing – TDFN SO8**

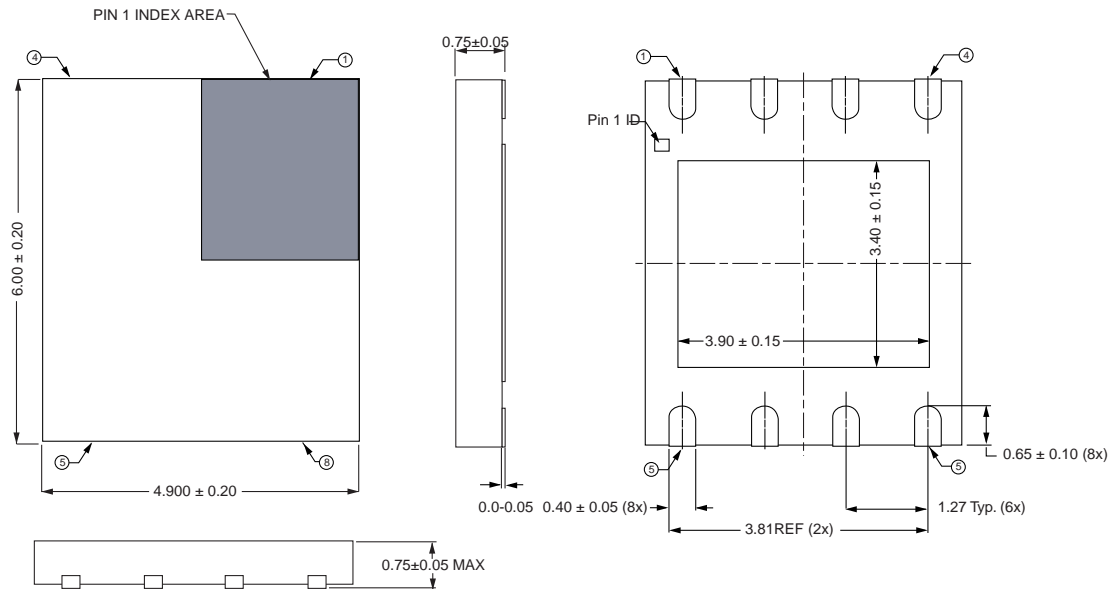

**Note: Dimensions in mm. TDFN SO8 Package has thermal power dissipation of 240°C/Watt in free air. Attaching the package to a circuit board improves thermal performance.**

**Package Drawing – PLLP6 3.0 mm x 3.0 mm**

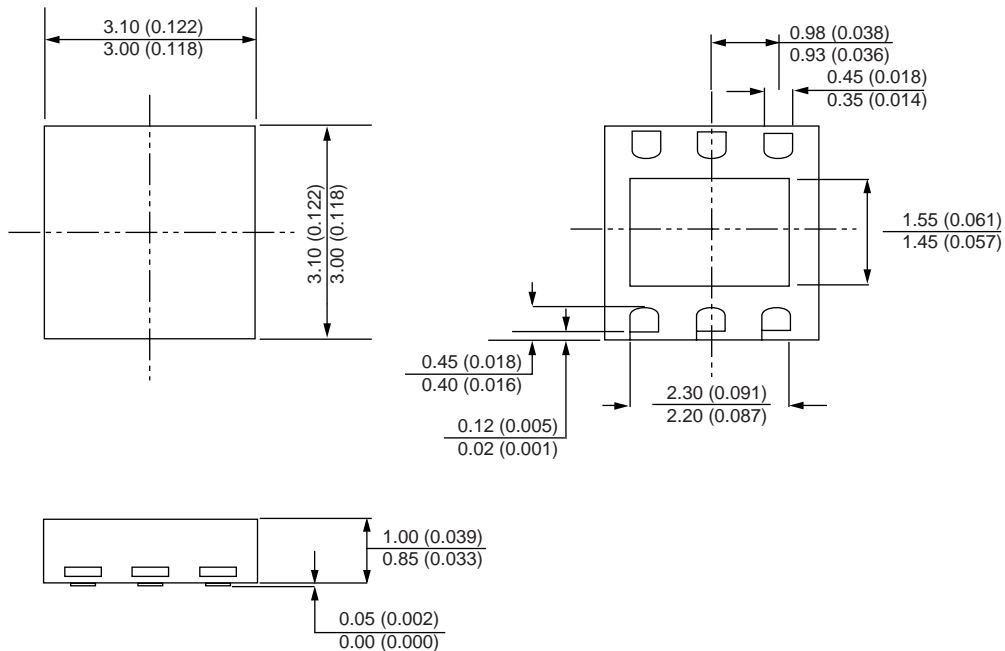

**Note:** The PLLP6 package has thermal power dissipation of 320°C/Watt in free air. Attaching the package to a circuit board improves thermal performance. Dimensions are in mm (inches).

**Note on Lead-Free Packages**

The electronics industry has been working to provide lead-free products in response to concerns about the environmental impact of the use of lead (Pb) in solder finishes. Increasing customer demand and directives to decrease the amounts of lead in consumer electronics products from governments around the globe, drives this effort.

Lead-free finishes utilizing pure tin (Sn) have already been qualified at NVE and are available in most of our products. However, additional lead times are associated with these parts.

Since most lead-free solders being used in board assembly environments have higher melting temperatures than traditional tin-lead solders, higher reflow temperatures may be necessary to form an equivalent solder joint between the component and the PC board. NVE characterizes all lead-free packages using elevated temperature (245°C to 260°C) reflow profiles characteristic of lead-free board assembly environments. All lead-free products will be identified with an “E” suffix on the part number and a lower case “e” marking on the package.

This lead-free transition is an important component of NVE’s commitment to take an active part in protecting the environment and our responsibility to our customers and the communities around the world in which we do business. We remain dedicated to meeting our customers’ requirements and expectations.

## Recommended Solder Reflow Profile

NVE recommends the following soldering profile:

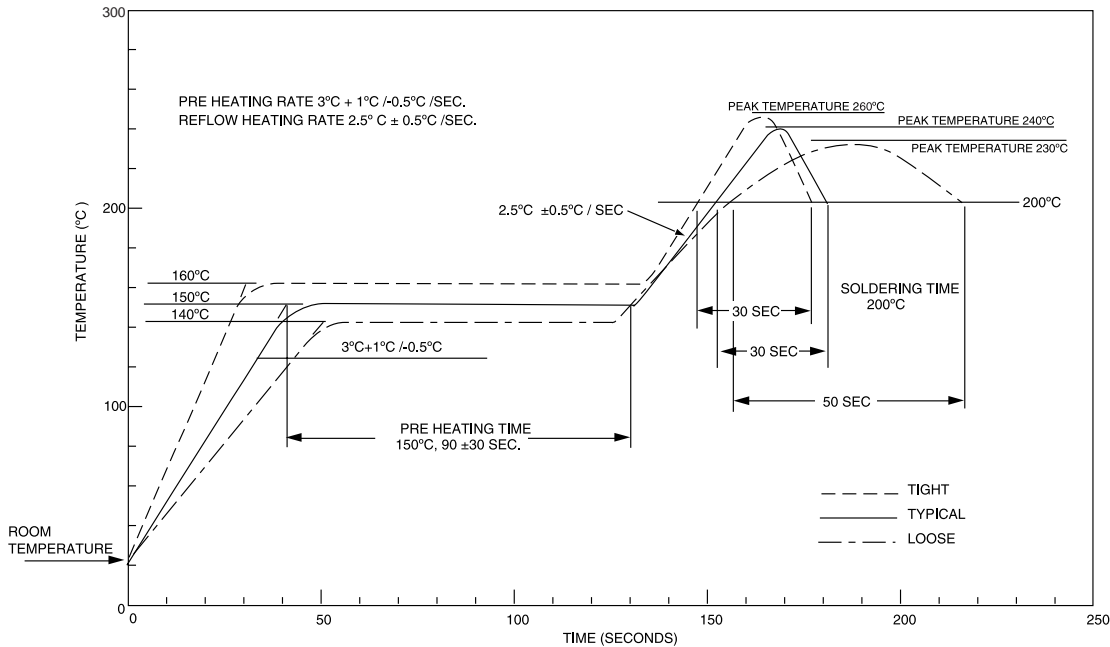

For leaded (Pb) parts, the peak temperature shown in this profile can be decreased to as low as  $230^{\circ}\text{C}$ .

Exceeding  $265^{\circ}\text{C}$  at peak or the time at peak temperature shown in this profile can damage the parts. Specifically:

1. AA- and AD-Series sensors are rated at  $150^{\circ}\text{C}$  maximum storage temperature. They can withstand the solder profile shown above with no harmful effects. However, temperatures above  $265^{\circ}\text{C}$  for even a brief period or extended periods above  $160^{\circ}\text{C}$  can cause degradation of the GMR sensor element.
2. AKL- and DD-Series parts contain an on-chip EEPROM. Exposure to temperatures in excess of  $265^{\circ}\text{C}$  can cause EEPROM data corruption, which will cause the parts to fall out of specification.

**Magnet Data**

NVE supplies Ceramic 8 magnets in some of our GMR sensor evaluation kits. The characteristics for these magnets are given below:

Material Type	Ceramic 8 (C8)
Maximum Operating Temperature	300°C
Curie Temperature	450°C
Temperature Coefficient of Flux Density	-0.20 %/°C
Maximum Energy Product	3.5 MGOe
Residual Induction	3850 Gauss
Coercive Force	2950 Oersteds

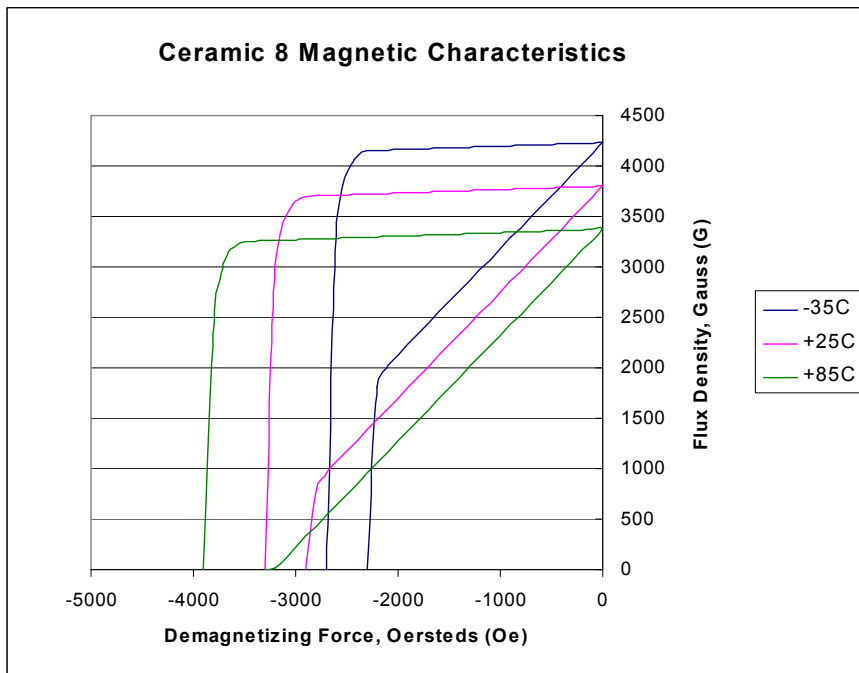

Magnet drawings for the two round disc magnets included in the GT Sensor evaluation kits are given below. These magnets are available from NVE as production parts. Contact NVE for pricing and delivery information. In addition, NVE can have custom magnets built for specific applications in Ceramic 8 or Alnico 8 materials. Please contact NVE for more details.

## Ceramic 8 Disc Magnets

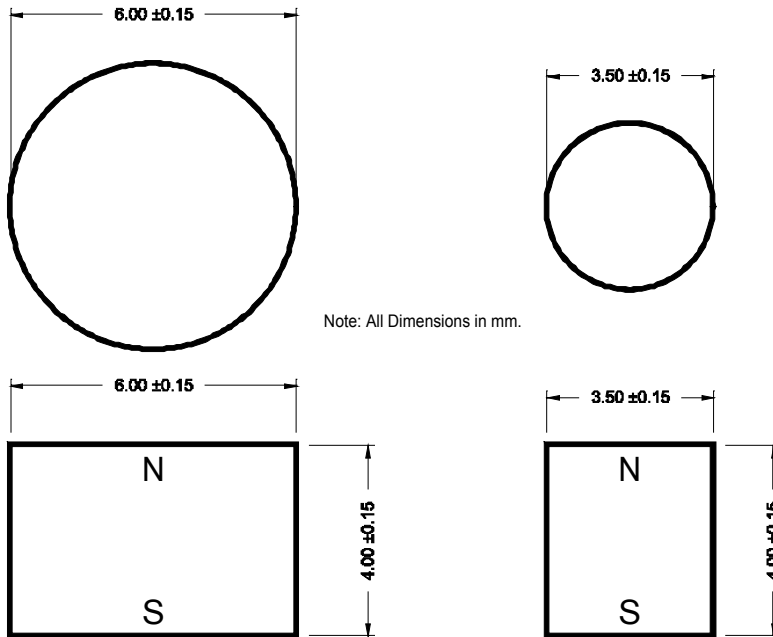

Magnet Part Number	Diameter (mm)	Length (mm)
12216	6	4
12217	3.5	4

## Part Numbers and Marking Codes

NVE's part number format consists of two or three letters, then three numbers, a dash, and then two more numbers, and in some cases a final letter. Here is an example:

### **AAH004-00E**

The meanings of the numbers and letters are defined as follows:

First Two Letters	General Part Description
AA	Analog output magnetometer or spin valve sensor
AB	Analog output gradiometer
AD	Digital output magnetometer
AG	Evaluation kit or printed circuit board assembly
AK	Digital output gradiometer
BD	Custom digital output magnetometer
DB	Digital input signal processing IC
DC	Voltage regulator
DD	Analog input signal processing IC

Third Letter	GMR Material Used In Product
	No third letter indicates NVE's standard multilayer material
H	High sensitivity, high temperature multilayer material
L	Low hysteresis, high temperature multilayer material
V	Spin valve material with synthetic anti-ferromagnet pinning

Three Digits	Consecutive Part Number
xxx	Meaning for AD-Series parts is described in the GMR Switch section of this catalog; other products have numbers assigned consecutively with no meaning implied

Two Digits After Dash	Package Type
-00	MSOP 8 pin package
-01	Raw IC (die); available in diced wafer on blue tape or waffle pack form
-02	SOIC 8 pin package
-07	Non-semiconductor style package; used for eval kits and PCBs
-10	TDFN6 2.5mm X 2.5mm 6 pin package
-11	PLL6 3.0mm X 3.0mm 6 pin package
-12	TDFN SO8 4.9mm X 6.0mm 8 pin package

Final Letter	Consecutive Part Number
E	No final letter means a standard package; E means a lead-free package

Some of NVE's products are delivered in packages that are too small to be marked with the complete part number. In these cases a three-letter code is used to identify the part. The following table provides a cross-reference from part number to marking code:

NVE Part Number	Code
AA004-00	CBD
AA006-00	CBC
AAH004-00	CBF
AAV001-11	BBP
AAV002-11	BBQ
AB001-00	CBG
ABH001-00	CBH
ABL004-00	FDB
ABL005-00	FDC
ABL006-00	FDL
ABL014-00	FDD
ABL015-00	FDG
ABL016-00	FDM
ABL004-10	FDG
ABL005-10	FDH
ABL006-10	FDN
ABL014-10	FDJ
ABL015-10	FDK
ABL016-10	FDP
AD004-00	BBH
AD005-00	BBG
AD006-00	BBJ
AD020-00	BBK
AD021-00	BBB
AD022-00	BBC
AD023-00	BBD
AD024-00	BBF
AD024-10	BBL
AD104-00	DBH
AD105-00	DBG
AD106-00	DBJ
AD120-00	DBK
AD121-00	DBB
AD122-00	DBC
AD123-00	DBD
AD124-00	DBF
AD204-00	FBH
AD205-00	FBG
AD206-00	FBJ
AD220-00	FBK
AD221-00	FBB
AD222-00	FBC
AD223-00	FBD
AD224-00	FBF
AD304-00	GBH
AD305-00	GBG
AD306-00	GBJ
AD320-00	GBK
AD321-00	GBB
AD322-00	GBC

NVE Part Number	Code
AD323-00	GBD
AD324-00	GBF
AD404-00	HBH
AD405-00	HBG
AD406-00	HBJ
AD420-00	HBK
AD421-00	HBB
AD422-00	HBC
AD423-00	HBD
AD424-00	HBF
AD504-00	JBH
AD505-00	JBG
AD506-00	JBK
AD520-00	JBK
AD521-00	JBB
AD522-00	JBC
AD523-00	JBD
AD524-00	JBF
AD604-00	KBH
AD605-00	KBG
AD606-00	KBK
AD620-00	KBK
AD621-00	KBB
AD622-00	KBC
AD623-00	KBD
AD624-00	KBF
AD704-00	LBH
AD705-00	LBG
AD706-00	LBJ
AD720-00	LBK
AD721-00	LBB
AD722-00	LBC
AD723-00	LBD
AD724-00	LBF
AD081-00	BDB
AD082-00	BDC
AD083-00	BDD
AD084-00	BDF
AD821-00	MBB
AD822-00	MBC
AD823-00	MBD
AD824-00	MBF
AD921-00	NBB
AD922-00	NBC
AD923-00	NBD
AD924-00	NBF
ADH025-00	MBL
BD012-00	ZBF
DB001-00	FFD
DC001-10	FFB
DC002-10	FFC

The following table provides a cross-reference from marking code to part number:

Code	NVE Part Number
BBB	AD021-00
BBC	AD022-00
BBD	AD023-00
BBF	AD024-00
BBG	AD005-00
BBH	AD004-00
BBJ	AD006-00
BBK	AD020-00
BBL	AD024-10
BBP	AAV001-11
BBQ	AAV002-11
BDB	AD081-00
BDC	AD082-00
BDD	AD083-00
BDF	AD084-00
CBC	AA006-00
CBD	AA004-00
CBF	AAH004-00
CBG	AB001-00
CBH	ABH001-00
DBB	AD121-00
DBC	AD122-00
DBD	AD123-00
DBF	AD124-00
DBG	AD105-00
DBH	AD104-00
DBJ	AD106-00
DBK	AD120-00
FBB	AD221-00
FBC	AD222-00
FBD	AD223-00
FBF	AD224-00
FBG	AD205-00
FBH	AD204-00
FBJ	AD206-00
FBK	AD220-00
FDB	ABL004-00
FDC	ABL005-00
FDD	ABL014-00
FDJ	ABL015-00
FDG	ABL004-10
FDH	ABL005-10
FDJ	ABL014-10
FDK	ABL015-10
FDL	ABL006-00
FDM	ABL016-00
FDN	ABL006-10
FDP	ABL016-10
FFB	DC001-10
FFC	DC002-10

Code	NVE Part Number
FFD	DB001-00
GBB	AD321-00
GBC	AD322-00
GBD	AD323-00
GBF	AD324-00
GBG	AD305-00
GBH	AD304-00
GBJ	AD306-00
GBK	AD320-00
HBB	AD421-00
HBC	AD422-00
HBD	AD423-00
HBF	AD424-00
HBG	AD405-00
HBH	AD404-00
HBJ	AD406-00
HBK	AD420-00
JBB	AD521-00
JBC	AD522-00
JBD	AD523-00
JBF	AD524-00
JBG	AD505-00
JBH	AD504-00
JBK	AD506-00
JBJ	AD506-00
JBK	AD520-00
KBB	AD621-00
KBC	AD622-00
KBD	AD623-00
KBF	AD624-00
KBG	AD605-00
KBH	AD604-00
KBJ	AD606-00
KBK	AD620-00
LBB	AD721-00
LBC	AD722-00
LBD	AD723-00
LBF	AD724-00
LBG	AD705-00
LBH	AD704-00
LBJ	AD706-00
LBK	AD720-00
MBB	AD821-00
MBC	AD822-00
MBD	AD823-00
MBF	AD824-00
MBL	ADH025-00
NBB	AD921-00
NBC	AD922-00
NBD	AD923-00
NBF	AD924-00
ZBF	BD012-00

## Definitions and Conversion Factors

### Definitions:

**CSK or Sink:** Current sinking output, also referred to as Open Collector output.

**Differential:** The field difference between the Operate Point and the Release Point.

**Electrical Offset:** The inherent imbalance of the bridge expressed in differential voltage output.

**HBM:** Human Body Model for ESD specifications.

**Hysteresis:** The maximum deviation in volts between the output with increasing field and the output with decreasing field, where the applied field is unipolar (applied in either a positive or negative direction, without crossing the zero field point), divided by Voltage Span. Expressed as a percentage.

**Input Voltage Range:** The voltage range that can be applied across the bridge.

**IOL (Current Output Low):** The output current in the low (logic 0) state (output stage switched on).

**Max Output:** A specification given in millivolts per applied voltage. This is the maximum output voltage possible. This output condition is achieved when one set of resistors is in magnetic saturation (have achieved the maximum resistance change possible) while the other pair are at zero applied magnetic field.

**Nonlinearity:** The maximum deviation from a linear fit taken over the Field Range divided by the Voltage Span. Expressed as a percentage.

**Off-axis Characteristic:** A specification that describes the variation in sensor output versus the angle between the applied field direction and the sensitive axis of the GMR sensor with constant electrical and magnetic inputs applied. Applicable to non-integrated bridge sensors. The output will vary as the cosine of the angle rotated.

**Operate Point:** The field level which produces a logical change in state from “0” to “1” in NVE’s digital magnetic field sensors ADXXX-XX.

**Operating Frequency:** Frequency range within which a sensor will produce a responsive output.

**Output Leakage Current (Current Output High):** The output current in the high (logic 1) state (output stage switched off).

**Output Saturation Voltage (Voltage Output Low):** The output voltage in the low (logic 0) state (output stage switched on).

**RBP:** Reverse Battery Protection.

**Release Point:** The field level which produces a logical change in state from “1” to “0” in NVE’s digital magnetic field sensors ADXXX-XX.

**Resistor Separation:** This is the mean separation between the two pairs of resistors, in a Gradiometer or Differential sensor.

**Sensitivity:** A measure of the output magnitude based on electrical and magnetic input conditions. Expressed in millivolts of differential output per applied voltage per Oersted.

**Specified Linear Range:** Typically 70% of the field it takes to saturate the part. Field dependent specifications are based upon this range.

**TCOI (Temperature Coefficient of Output at Constant Input Current):** The variation of the output voltage over temperature with a constant input current applied. Expressed as a percentage per unit temperature change.

**TCOV (Temperature Coefficient of Output at Constant Input Voltage):** The variation of the output voltage over temperature with a constant input voltage applied. Expressed as a percentage per unit temperature change.

**TCR (Temperature Coefficient of Resistance):** The variation of the GMR resistors over temperature. Expressed as a percentage per unit temperature change.

**Voltage Span:** The differential output voltage taken from zero to 70% of the saturation field level.

**Conversion Factors**

To Convert	Into	Multiply by
$\mu\text{Wb}$	maxwell	$10^2$
A/cm	Oe	1.256
A/m	Oe	$1.256 \times 10^{-2}$
At	Gb	1.256
G	Oe	1 (when $\mu_0=1$ )
G	T	$10^{-4}$
G	mT	$10^{-1}$
G	nT	$10^5$
G	Wb/cm <sup>2</sup>	$10^{-8}$
G	Wb/in <sup>2</sup>	$6.452 \times 10^{-8}$
G	Wb/m <sup>2</sup>	$10^{-4}$
Gb	At	0.796
kA/m	Oe	$1.256 \times 10^1$
maxwell	Wb	$10^{-8}$
maxwell	$\mu\text{Wb}$	$10^{-2}$
mT	G	10
maxwell	volt second	$10^{-8}$
nT	G	$10^{-5}$
nT	gamma ( $\gamma$ )	1
Oe	A/cm	$7.962 \times 10^{-1}$
Oe	A/m	$7.962 \times 10^1$
Oe	kA/m	$7.962 \times 10^{-2}$
T	G	$10^4$
T	Wb/m <sup>2</sup>	1
volt second	maxwell	$10^8$
volt second	Wb	1
Wb	maxwell	$10^8$
Wb/cm <sup>2</sup>	G	$10^8$
Wb/m <sup>2</sup>	G	$10^4$

### About NVE

NVE Corporation develops and sells devices using spintronics, a nanotechnology we helped pioneer, which utilizes electron spin rather than electron charge to acquire, store and transmit information.

We make spintronics practical by manufacturing high-performance products including sensors and couplers that are used in industrial, scientific, and medical applications. We have also licensed our spintronic magnetoresistive random access memory technology, commonly known as MRAM.

Sensors acquire information, couplers transmit information, and memories store information. Thus our technology can provide the eyes, nerves, and brains of electronic systems. NVE's award-winning products are sold through a worldwide distribution network.

The company is located in Eden Prairie, Minnesota, a suburb of Minneapolis.

Please visit our web site or call our toll free number for information on products, sales, or distribution.

An ISO 9001 Certified Company

NVE Corporation  
11409 Valley View Road  
Eden Prairie, MN 55344 USA  
Telephone: (952) 829-9217  
Fax: (952) 829-9189  
[www.nve.com](http://www.nve.com)  
e-mail: [sensor-info@nve.com](mailto:sensor-info@nve.com)

©NVE Corporation

All rights are reserved. Reproduction in whole or in part is prohibited without the prior written consent of the copyright owner.

SB-00-014

*February 6, 2012*

**Datasheet Limitations**

The information and data provided in datasheets shall define the specification of the product as agreed between NVE and its customer, unless NVE and customer have explicitly agreed otherwise in writing. All specifications are based on NVE test protocols. In no event however, shall an agreement be valid in which the NVE product is deemed to offer functions and qualities beyond those described in the datasheet.

**Limited Warranty and Liability**

Information in this catalog is believed to be accurate and reliable. However, NVE does not give any representations or warranties, expressed or implied, as to the accuracy or completeness of such information and shall have no liability for the consequences of use of such information.

In no event shall NVE be liable for any indirect, incidental, punitive, special or consequential damages (including, without limitation, lost profits, lost savings, business interruption, costs related to the removal or replacement of any products or rework charges) whether or not such damages are based on tort (including negligence), warranty, breach of contract or any other legal theory.

**Right to Make Changes**

NVE reserves the right to make changes to information published in this catalog including, without limitation, specifications and product descriptions at any time and without notice. This document supersedes and replaces all information supplied prior to its publication.

**Use in Life-Critical or Safety-Critical Applications**

Unless NVE and a customer explicitly agree otherwise in writing, NVE products are not designed, authorized or warranted to be suitable for use in life support, life-critical or safety-critical devices or equipment. NVE accepts no liability for inclusion or use of NVE products in such applications and such inclusion or use is at the customer's own risk. Should the customer use NVE products for such application whether authorized by NVE or not, the customer shall indemnify and hold NVE harmless against all claims and damages.

**Applications**

Applications described in this catalog are illustrative only. NVE makes no representation or warranty that such applications will be suitable for the specified use without further testing or modification.

Customers are responsible for the design and operation of their applications and products using NVE products, and NVE accepts no liability for any assistance with applications or customer product design. It is customer's sole responsibility to determine whether the NVE product is suitable and fit for the customer's applications and products planned, as well as for the planned application and use of customer's third party customers. Customers should provide appropriate design and operating safeguards to minimize the risks associated with their applications and products.

NVE does not accept any liability related to any default, damage, costs or problem which is based on any weakness or default in the customer's applications or products, or the application or use by customer's third party customers. The customer is responsible for all necessary testing for the customer's applications and products using NVE products in order to avoid a default of the

applications and the products or of the application or use by customer's third party customers. NVE accepts no liability in this respect.

**Limiting Values**

Stress above one or more limiting values (as defined in the Absolute Maximum Ratings System of IEC 60134) will cause permanent damage to the device. Limiting values are stress ratings only and operation of the device at these or any other conditions above those given in the recommended operating conditions of the datasheet is not warranted. Constant or repeated exposure to limiting values will permanently and irreversibly affect the quality and reliability of the device.

**Terms and Conditions of Sale**

In case an individual agreement is concluded only the terms and conditions of the respective agreement shall apply. NVE hereby expressly objects to applying the customer's general terms and conditions with regard to the purchase of NVE products by customer.

**No Offer to Sell or License**

Nothing in this document may be interpreted or construed as an offer to sell products that is open for acceptance or the grant, conveyance or implication of any license under any copyrights, patents or other industrial or intellectual property rights.

**Export Control**

This document as well as the items described herein may be subject to export control regulations. Export might require a prior authorization from national authorities.

**Automotive Qualified Products**

Unless the datasheet expressly states that a specific NVE product is automotive qualified, the product is not suitable for automotive use. It is neither qualified nor tested in accordance with automotive testing or application requirements. NVE accepts no liability for inclusion or use of non-automotive qualified products in automotive equipment or applications.

In the event that customer uses the product for design-in and use in automotive applications to automotive specifications and standards, customer (a) shall use the product without NVE's warranty of the product for such automotive applications, use and specifications, and (b) whenever customer uses the product for automotive applications beyond NVE's specifications such use shall be solely at customer's own risk, and (c) customer fully indemnifies NVE for any liability, damages or failed product claims resulting from customer design and use of the product for automotive applications beyond NVE's standard warranty and NVE's product specifications.