



I²C selector guide 2016

A broad catalog of interface components
for all your design needs



I²C-bus: The serial revolution

By replacing complex parallel interfaces with a straightforward yet powerful serial structure, the I²C-bus revolutionized chip-to-chip communications.

Invented by NXP (Philips) more than 30 years ago, the I²C-bus uses a simple two-wire format to carry data one bit at a time. It performs inter-chip addressing, selection, control, and data transfer. Speeds are up to 400 kHz (Fast-mode), 1 MHz (Fast-mode Plus) or 3.4 MHz (High Speed-mode).

The I²C-bus shrinks the IC footprint and leads to lower IC costs. Plus, since far fewer copper traces are needed, it enables a smaller PCB, reduces design complexity, and lowers system cost.

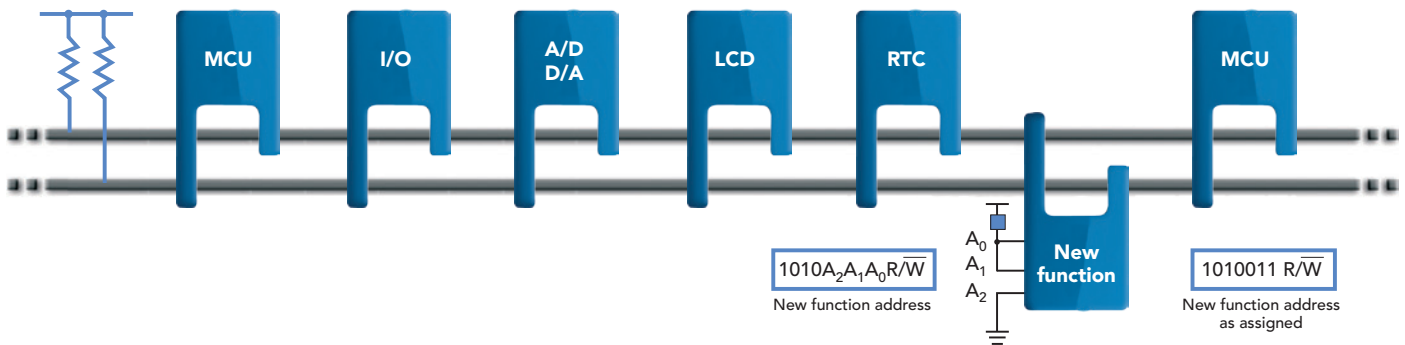
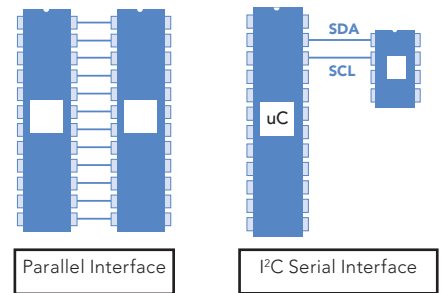

I²C-bus devices are available in a wide range of functions. Each slave device has its own I²C-bus address, selectable using address pins set high (1) or low (0). Information is transmitted byte by byte, and each byte is acknowledged by the receiver. There can be multiple devices on the same bus, and more than one IC can act as master. The master role is typically played by a microcontroller.

Write data

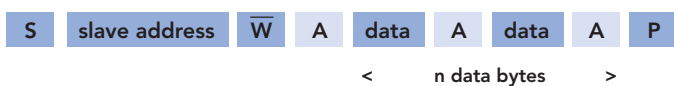

Read data

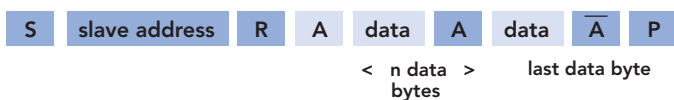

S = Start condition R/W = read/write
A = Acknowledge A-bar = Not acknowledge P = Stop condition

Master

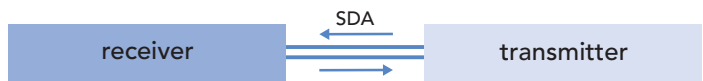

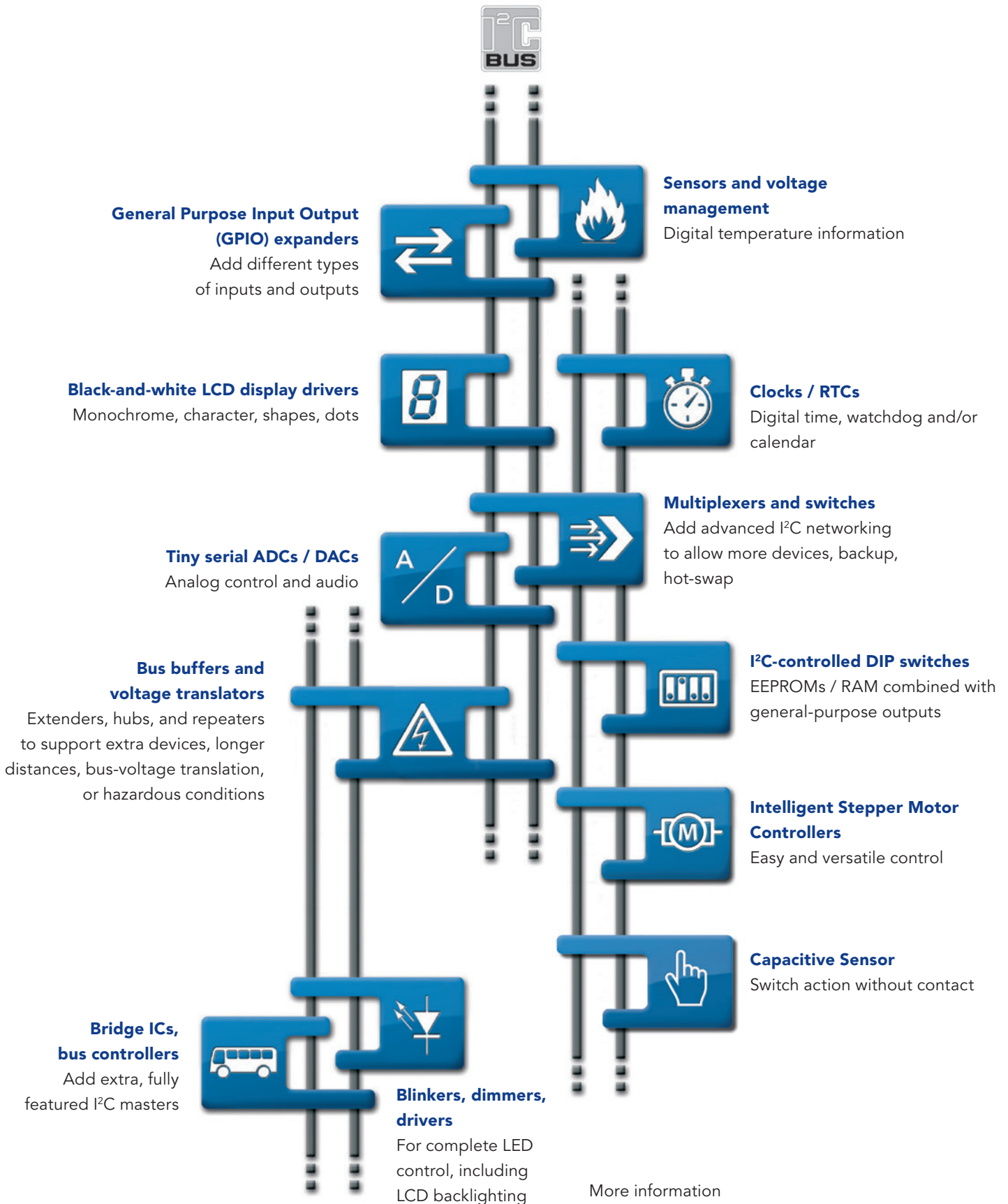

The master always sends the clock

NXP's I²C peripherals portfolio is grouped into twelve families, one for each of the most common, everyday design concerns.





I²C-bus product summary

GPIO Expander		
4-bit	PCA9536	4-bit I ² C Fm TP GPIO with PU
	PCA9537	4-bit I ² C Fm TP GPIO with INT and RST
	PCA9570	4-bit 1 MHz LV TP GPO
8-bit	PCA8574	8-bit I ² C Sm QB GPIO with INT and PU
	PCF8574	8-bit I ² C Fm QB GPIO with INT and PU
	PCA8574A	8-bit I ² C Fm QB GPIO with INT and PU (Alternate address)
	PCF8574A	8-bit I ² C Sm QB GPIO with INT and PU (Alternate address)
	PCA9500	8-bit I ² C Fm QB GPIO with PU and 2-K EEPROM
	PCA9501	8-bit I ² C Fm QB GPIO with INT, PU and 2-K EEPROM
	PCA9502	8-bit I ² C Fm/SPI TP GPIO with INT and RST
	PCA9534	8-bit I ² C Fm TP GPIO with INT
	+ PCA9538	8-bit I ² C Fm TP GPIO with INT and RST
	PCA9538A	8-bit I ² C Fm LV TP GPIO with INT and RST
	PCAL9538A	8-bit I ² C Fm LV TP/OD GPIO with INT, RST, latch and PU/PD
	PCA6408A	8-bit I ² C Fm LV VLT TP GPIO with INT and RST
	PCAL6408A	8-bit I ² C Fm LV VLT TP/OD GPIO with INT, RST, latch and PU/PD
	PCA9554	8-bit I ² C Fm TP GPIO with INT and PU
	PCA9554A	8-bit I ² C Fm TP GPIO with INT and PU (alternate address for PCA9554)
	PCA9554B	8-bit I ² C Fm LV TP GPIO with INT and PU
	PCAL9554B	8-bit I ² C Fm LV TP/OD GPIO with INT, latch and PU/PD (PU default)
	PCA9554C	8-bit I ² C Fm LV TP GPIO with INT and PU (alternate address for PCA9554B)
	PCAL9554C	8-bit I ² C Fm LV TP/OD GPIO with INT, latch and PU/PD (PU default) (alternate address for PCAL9554B)
	PCA9557	8-bit I ² C Fm TP GPIO with RST
	PCA9571	8-bit 1 MHz LV TP GPO
	PCA9574	8-bit I ² C Fm LV VLT TP/OD GPIO with INT, RST, latch and PU/PD
	PCA9670	8-bit I ² C Fm+ QB GPIO with RST and PU
	PCA9672	8-bit I ² C Fm+ QB GPIO with INT, RST and PU
	PCA9674	8-bit I ² C Fm+ QB GPIO with INT and PU
	PCA9674A	8-bit I ² C Fm+ QB GPIO with INT and PU (Alternate address)
	PCA9702	8-bit SPI 18V GPI with INT
PCA9704	8-bit SPI 18V GPI with maskable INT	
16-bit	PCA8575	16-bit I ² C Fm QB GPIO with INT and PU
	PCF8575	16-bit I ² C Fm QB GPIO with INT and PU
	PCF8575C	16-bit I ² C Fm OD GPIO with INT
	PCA9535	16-bit I ² C Fm TP GPIO with INT
	PCA9535C	16-bit I ² C Fm OD GPIO with INT
	PCA9535A	16-bit I ² C Fm LV TP GPIO with INT
	PCAL9535A	16-bit I ² C Fm LV TP/OD GPIO with INT, latch and PU/PD
	+ PCA9539	16-bit I ² C Fm TP GPIO with INT and RST
	PCA9539R	16-bit I ² C Fm TP GPIO with INT and RST (state machine only)
	PCA9539A	16-bit I ² C Fm LV TP GPIO with INT and RST
	PCAL9539A	16-bit I ² C Fm LV TP/OD GPIO with INT, RST, latch and PU/PD
	PCA6416A	16-bit I ² C Fm LV VLT TP GPIO with INT and RST
	PCAL6416A	16-bit I ² C Fm LV VLT TP/OD GPIO with INT, RST, latch and PU/PD
	PCA9555	16-bit I ² C Fm TP GPIO with INT and PU
	PCA9555A	16-bit I ² C Fm LV TP GPIO with INT and PU
	PCAL9555A	16-bit I ² C Fm LV TP/OD GPIO with INT, latch and PU/PD (PU default)
	PCA9575	16-bit I ² C Fm LV VLT TP/OD GPIO with INT, RST, latch and PU/PD
	PCA9671	16-bit I ² C Fm+ QB GPIO with RST and PU
	PCA9673	16-bit I ² C Fm+ QB GPIO with INT, RST and PU
	PCA9675	16-bit I ² C Fm+ QB GPIO with INT and PU
	PCA9701	16-bit SPI 18V GPI with INT
PCA9703	16-bit SPI 18V GPI with maskable INT	
24-bit	PCA6524	24-bit ULV GPIO with Agile I/O Plus Features
40-bit	PCA9505	40-bit I ² C Fm TP GPIO with INT, RST, OE and PU
	PCA9506	40-bit I ² C Fm TP GPIO with INT, RST and OE
	PCA9698	40-bit I ² C Fm+ TP/OD GPIO with INT, RST, OE and PU

Stepper Motor Controller		
1 motor controller	PCA9629A	Improved I ² C Fm+ Stepper Motor Controller with TP GPIO with INT and RST

Capacitive Sensor		
1-channel touch switch	PCF8883	I ² C Fm+ Touch / Proximity Sensor for one switch
2-channel touch switch	+ PCA8886	I ² C Fm+ Touch / Proximity Sensor for two switches
8-channel touch switch	+ PCA/PCF8885	I ² C Fm+ Touch / Proximity Sensor for up to 28 keys

Temp sensors		
Local	LM75B	I ² C Fm TS local with ± 2 °C accuracy and SMBus time-out
	SE95	I ² C Fm TS local with ± 1 °C accuracy (NRND)
	SE98A	I ² C FmDDR TS, no SPD, +/- 1°C accuracy and SMBus time-out
	PCT2075	I ² C Fm+ TS with +/- 1°C accuracy and SMBus time-out
	PCT2202	I ² C HSm TS, 1.8 V, +/- 1°C accuracy and SMBus time-out
Local and EEPROM	SE97B	I ² C Fm DDR TS local with ± 1 °C accuracy, 2K SPD and SMBus time-out
Local and remote	NE1617A	I ² C Fm TS local with ± 2 °C accuracy and remote with ± 3 °C accuracy
	SA56004	I ² C Fm TS local with ± 2 °C accuracy and remote with ± 1 °C accuracy

LED controllers		
Dimmer (2 PWM, 25 mA / 5 V)	PCA9530	2-channel I ² C Fm OD LED dimmer with RST
	PCA9531	8-channel I ² C Fm OD LED dimmer with RST
	PCA9532	16-channel I ² C Fm OD LED dimmer with RST
	PCA9533	4-channel I ² C Fm OD LED dimmer
Blinker (2 PWM, 25 mA / 5 V)	PCA9550	2-channel I ² C Fm OD LED blinker with RST
	PCA9551	8-channel I ² C Fm OD LED blinker with RST
	PCA9552	16-channel I ² C Fm OD LED blinker with RST
	PCA9553	4-channel I ² C Fm OD LED blinker
Controller (PWM / Ch, 25 mA / 5 V)	PCA9632	4-channel I ² C Fm+ low-power TP LED controller
	PCA9633	4-channel I ² C Fm+ TP LED controller with OE
	PCA9634	8-channel I ² C Fm+ TP LED controller with OE
	+ PCA9635	16-channel I ² C Fm+ TP LED controller with OE
	+ PCA9685	16-channel I ² C Fm+ TP LED controller with 12-bit PWMs and OE
Controller (PWM/Ch, 57 mA / 20 V)	+ PCA9955B	16-channel I ² C Fm+ 20 V CS LED controller
	+ PCA9745B	16-channel SPI 20 V CS LED Controller
	PCA9956B	24-channel I ² C Fm+ 20 V CS LED controller
Controller (PWM / Ch, 57 mA / 40 V)	+ PCA9952	16-channel I ² C Fm+ HV CS LED controller with OE
	+ PCA9955	16-channel I ² C Fm+ HV CS LED controller
Controller (PWM / Ch, 100 mA / 20 V)	PCA9655A	16-channel I ² C Fm+ 20 V OD LED Controller
Controller (PWM / Ch, 100 mA / 40 V)	PCA9624	8-channel I ² C Fm+ HV OD LED controller with OE
	PCA9622	16-channel I ² C Fm+ HV OD LED controller with OE
	PCA9626	24-channel I ² C Fm+ HV OD LED controller with OE

Real-time clocks		
Low-power	PCF85063	I ² C Fm / Tiny RTC with 30s, 60s interrupt
	PCF85063A	I ² C Fm / Tiny RTC with Alarm and 30s, 60s interrupt
	PCF85263A	I ² C Fm / Tiny RTC with Alarms, time stamp and battery back-up switch
	PCF85363A	I ² C Fm / Tiny RTC with Alarms, time stamp and battery back-up switch + 64Byte RAM
	PCF8523	I ² C Fm+ Ultra low-power RTC with loss of main power detection and automatic battery back-up
	PCF8563	I ² C Fm low-power clock/calendar
Automotive High temperature	+PCA85063A	I ² C Fm / Tiny RTC with Alarm and 30s, 60s interrupt -40°C...+105°C
	+PCA8565	I ² C Fm High temperature clock/calendar -40°C...+125°C
	+PCA2129	I ² C Fm High-accuracy, low voltage RTC with time stamp -40°C...+85°C
Temperature compensated high accuracy	PCF2127(A)	I ² C Fm High-accuracy, low-voltage RTC with time stamp and 512 x 8 RAM
	PCF2129(A)	I ² C Fm High-accuracy, low voltage RTC with time stamp

Muxes and switches		
2-channel	PCA9540B	2-channel I ² C Fm mux
	PCA9542A	2-channel I ² C Fm mux with INT
	PCA9543A/B	2-channel I ² C Fm switch with INT and RST
2-to-1 demux	PCA9541A/01	2 to 1 I ² C Fm demux with INT and RST (channel 0 default)
	PCA9541A/03	2 to 1 I ² C Fm demux with INT and RST (no channel default)
4-channel	PCA9544A	4-channel I ² C Fm mux with INT
	PCA9545A/B/C	4-channel I ² C Fm switch with INT and RST (B alternate address)
	PCA9546A	4-channel I ² C Fm switch with RST
	PCA9846	ULV 4-channel switch with RST, two power supplies, Fm+
	PCA9849	ULV 4-channel mux with RST, two power supplies
8-channel	PCA9547	8-channel I ² C Fm mux with RST (channel 0 default)
	PCA9847	ULV 8-channel mux with RST, two power supplies
	PCA9548A	8-channel I ² C Fm switch with RST
	PCA9848	ULV 8-channel switch with RST, two power supplies, Fm+
Arbiter	PCA9641	2 masters to shared slave I ² C Fm+ arbiter with INT and RST (no channels selected at default)

Bus buffers		
Incremental Offset	PCA9510A	I ² C Fm Incremental Offset hot-swap bus buffer (no RTA)
	PCA9511A	I ² C Fm Incremental Offset hot-swap-bus buffer
	PCA9512A	I ² C Fm Incremental Offset VLT hot swap bus buffer
	PCA9513A	I ² C Fm Incremental Offset hot-swap bus buffer (92 µA CS)
	PCA9514A	I ² C Fm Incremental Offset hot-swap bus buffer (0.8 V offset)
	Differential Driver with Static Offset (1 side)	PCA9614
PCA9615		I ² C Fm+ VLT differential (4 wire) hot-swap bus buffer
PCA9616		I ² C Fm+ 0.8V LV VLT differential (4 wire) hot-swap bus buffer with INT (2 wire)
Amplifier	P82B715	I ² C Fm HV bus extender
No Offset	PCA9646	4-channel I ² C Fm+ No Offset buffer / switch with RST
Static Offset (1 side)	P82B96	I ² C Fm HV bus buffer
	PCA9507	I ² C Fm VLT DDC buffer with accelerator
	PCA9508	I ² C Fm VLT hot-swap bus repeater
	PCA9509	I ² C Fm 1.0V LV VLT bus buffer with current source
	PCA9509A	I ² C Fm 0.8V LV VLT bus buffer with current source
	PCA9509P	I ² C Fm 0.8V LV VLT bus buffer
	PCA9517A	I ² C Fm 0.9V LV VLT bus repeater
	PCA9519	4-channel version of PCA9509
	PCA9527	I ² C Fm DDC VLT buffer with accelerator and CEC
	PCA9600	I ² C Fm+ HV bus buffer
	PCA9601	I ² C Fm+ HV bus buffer with stronger 15 mA local side drive to support multiple Fm+ slaves
	PCA9617A	I ² C Fm+ 0.8 V LV VLT bus repeater
	PCA9515A	I ² C Fm bus repeater
	PCA9516A	I ² C Fm 5-channel hub
PCA9518A	I ² C Fm expandable 5-channel hub	
Voltage translator (doesn't isolate capacitance)	GTL2000	22-bit I ² C Fm+ VLT
	GTL2002	2-bit I ² C Fm+ VLT
	GTL2003	8-bit I ² C Fm+ VLT
	GTL2010	10-bit I ² C Fm+ VLT
	PCA9306	Dual I ² C/SMBus Fm+ VLT
	NVT2001	1-bit I ² C Fm+ VLT
	NVT2002	2-bit I ² C Fm+ VLT for I ² C/SMBus applications
	NVT2003	3-bit I ² C Fm+ VLT for two power supply applications
	NVT2006	6-bit I ² C Fm+ VLT
	NVT2008	8-bit I ² C Fm+ VLT
NVT2010	10-bit I ² C Fm+ VLT	

Decode table

Code	Description
Sm	100 kHz Standard-mode I ² C-bus
Fm	400 kHz Fast-mode I ² C-bus
Fm+	1 MHz Fast-mode Plus I ² C-bus
HSm	3.4 MHz High Speed-mode I ² C-bus
NRND	Not recommended for new designs
+	AEC-Q100 compliance
GPIO	General Purpose I/O Expander
TS	Thermal Sensor
RTC	Real Time Clock
LCD	Liquid Crystal Display

Code	Description
DAC	Digital Analog Converter
ADC	Analog Digital Converter
LV	Supply voltage < 2.3 V
VLV	Supply voltage < 1.65 V
ULV	Supply voltage < 1.0 V
HV	Outputs >10 V
VLT	Voltage Level Translator – 2 Supplies
TP	Totem-pole (push-pull)
QB	Quasi-bidirectional
OD	Open drain

Code	Description
CS	Current source
INT	Interrupt
RST	Reset
OE	Output enable
Latch	Input latch
PU	Pull-up resistors
PU/PD	Pull-up/pull-down resistors
COG	Chip on Glass

LCD drivers		
Segment driver	+ PCA8561A/B	I ² C Fm 72-segment low-power LCD driver in HVQFN32 package
	PCF8566	I ² C Fm 96-segment low-power LCD driver in VSO40 package
	+ PCA/PCF85162	I ² C Fm 128-segment LCD driver in TSSOP48 package
	+ PCA85262	I ² C Fm 128-segment LCD driver with higher frame frequency in TSSOP48 package
	+ PCA/PCF8551A/B	I ² C Fm 144-segment low-power LCD driver with programmable frame frequency in TSSOP48 package
	+ PCA/PCE/PCF85176	I ² C Fm 160-segment LCD driver in TSSOP56 or TQFP64 package
	+ PCA85276	I ² C Fm 160-segment LCD driver with higher frame frequency in TSSOP56 package
	+ PCA/PCF8553A/B	I ² C Fm 160-segment low-power LCD driver with programmable frame frequency in TSSOP56 package
	+ PCA8546	I ² C Fm 176-segment LCD driver with programmable frame frequency in TSSOP56 package
	+ PCA8547	I ² C Fm 176-segment LCD driver with programmable frame frequency, charge pump, VLCD temperature compensation in TQFP64 package
	+ PCA/PCF85134	I ² C Fm 240-segment LCD driver in LQFP80 package
	+ PCA8543	I ² C Fm 240-segment LCD driver with programmable frame frequency, charge pump, VLCD temperature compensation in LQFP80 package
	+ PCF8545	I ² C Fm 320-segment LCD driver with programmable frame frequency in TSSOP56 package
	+ PCA/PCF8536	I ² C Fm 320-segment LCD driver with programmable frame frequency and LED backlight PWM control in TSSOP56 package
	+ PCA/PCF8537	I ² C Fm 352-segment LCD driver with programmable frame frequency, charge pump, VLCD temperature compensation in TQFP64 package
	+ PCA9620	I ² C Fm 480-segment LCD driver with programmable frame frequency, charge pump, VLCD temperature compensation in LQFP80 package
	+ PCA/PCF8576D/E	I ² C Fm 160-segment COG LCD driver
	+ PCA8576F	I ² C Fm 160-segment COG LCD driver with higher frame frequency and higher VLCD
	+ PCA/PCE/PCF85133	I ² C Fm 320-segment COG LCD driver with selectable frame frequency
	+ PCA85233	I ² C Fm 320-segment COG LCD driver with higher selectable frame frequency
+ PCA8530	I ² C Fm 408-segment COG LCD driver with programmable frame frequency, charge pump, VLCD temperature compensation	
+ PCA/PCF85132	I ² C Fm 640-segment COG LCD driver with programmable frame frequency	
+ PCA85232	I ² C Fm 640-segment COG LCD driver with higher programmable frame frequency	
+ PCA/PCF8538	I ² C Fm 918-segment COG LCD driver with programmable frame frequency, charge pump, VLCD temperature compensation	
Character drivers	PCF2119	I ² C Fm 2 x 16 characters + 160-icon COG LCD driver with charge pump, VLCD temperature compensation
	PCF21219	I ² C Fm 2 x 16 characters + 160-icon COG LCD driver with higher frame frequency, charge pump, VLCD temperature compensation
	+ PCA2117	I ² C Fm 2 x 20 characters + 200-icon COG LCD driver with programmable frame frequency, charge pump, VLCD temperature compensation
Graphic driver	+ PCA8539	I ² C Fm 18 x 100-pixel COG LCD driver with programmable frame frequency, charge pump, VLCD temperature compensation
	PCF8531	I ² C Fm 34 x 128-pixel COG LCD driver with charge pump, VLCD temperature compensation
	PCF8578	I ² C Sm 8x32 dot matrix LCD driver
	PCF8579	I ² C Sm, up to 40,960 dots when combined with 32x PCF3278

A/D-D/A converters			
8-bit ADC	PCF8591	I ² C Fm 4-channel ADC and 1-channel DAC	

EEPROMs			
2-kbit	PCA9500	I ² C Fm 256 x 8-bit EEPROM	
	PCA9501	I ² C Fm 256 x 8-bit EEPROM	
	PCF85103C	I ² C Sm 256 x 8-bit EEPROM (No programming time control output with ALT address) NRND	
	PCF8570	I ² C Sm 256 x 8-bit RAM	
4-kbit	PCF8594C	I ² C Sm 1024 x 8-bit EEPROM NRND	
8-kbit	PCA24S08A	I ² C Fm 1024 x 8-bit EEPROM with access protection	
	NT3H1101W0F	I ² C Fm 888 bytes EEPROM with dual interface NFC tag IC with power harvesting and field detect	
DIP switch	PCA8550	I ² C Fm 4-bit 1-of-2 mux & 5-bit EEPROM	
	PCA9558	I ² C Fm 5-bit MP/1-bit latch & 6-bit EEPROM with 2K EEPROM and 8-bit GPIO	
	PCA9559	I ² C Fm 5-bit mux/1-bit latch & 6-bit EEPROM	
	PCA9560	I ² C Fm 2 x 5-bit mux/1-bit latch & 6-bit EEPROM	
	PCA9561	I ² C Fm 4 x 6-bit mux & 6-bit EEPROM	

Bridge and bus controllers			
Bridge	SC16IS740	I ² C Fm/SPI-to-UART bridge with IrDA	
	SC16IS741	I ² C Fm/SPI-to-UART bridge with IrDA	
	SC16IS750	I ² C Fm/SPI-to-UART bridge with IrDA and GPIO	
	SC16IS752	I ² C Fm/SPI-to-DUART bridge with IrDA and GPIO	
	SC16IS760	I ² C Fm/SPI-to-UART bridge with IrDA and GPIO	
	SC16IS762	I ² C Fm/SPI-to-DUART bridge with IrDA and GPIO	
	SC18IM700	UART-to-I ² C Fm master bridge with GPIO	
	SC18IS600	SPI-to-I ² C Fm master bridge, 4 M with GPIO	
	SC18IS602	I ² C Fm slave-to-SPI master bridge	
	Controller	PCF8584	I ² C Sm bus controller with bus snoop
PCA9564		I ² C Fm bus controller	
PCA9661		1-channel I ² C Fm+ bus controller with 4 K-byte buffer	
PCA9663		3-channel I ² C Fm+ bus controller with 4 K-byte buffer per channel	
PCA9665		I ² C Fm+ bus controller with 68-byte buffer	
PCA9665A		I ² C Fm+ bus controller with 68-byte buffer and restart condition fix	
PCU9669		1-channel Fm+ and 2-channel U ² C Fm bus controller with 4 K-byte buffer per channel	

Level transceivers			
GTL to LVTTTL converters	GTL2005	4-bit GTL/GTL+ to LVTTTL/TTL bi-directional non-latched translator	
	GTL2006	13-bit GTL-/GTL/GTL+ to LVTTTL translator	
	GTL2007	12-bit GTL to LVTTTL translator	
	GTL2008	12-bit GTL to LVTTTL translator high-impedance LVTTTL and GTL outputs	
	GTL2012	2-bit LVTTTL to GTL transceiver	
	GTL2014	4-bit LVTTTL to GTL transceiver	
	+ GTL2018	8-bit LVTTTL to GTL transceiver	
	GTL2034	4-bit GTL to GTL buffer	
	GTL2107	12-bit GTL-/GTL/GTL+ to LVTTTL translator	

Demo boards	
Bridges	OM6270 SPI/I ² C to UART Bridge demo board (SC16IS750 / SC16IS760)
	OM6271 SPI to I ² C Master Bridge demo board (SC18IS600)
	OM6272 UART to I ² C Master Bridge demo board (SC18IM700)
	OM6273 SPI/I ² C to dual UART/IRDA/GPIO demo board (SC16IS752/SC16IS762)
	OM6274 I ² C to SPI Master Bridge demo board (SC18IS602)
Fm+ universal	OM13257 Universal temperature sensor daughter card for Fm+ demo board
	OM13320 Fm+ demonstration kit, including GPIO target board, buffer board and bridge board
	OM13488 Fm+ demonstration kit universal 8-bit GPIO daughter card
	OM13489 Fm+ demonstration kit universal 16-bit GPIO daughter card
	OM13529 Fm+ demonstration kit universal 24-bit GPIO daughter card
	OM13491 Breakout board panel A VSSOP8, XQFN8, HWSON8, MSOP8
	OM13492 Breakout board panel B various 6, 8, & 10-pin packages
	OM13493 Breakout board panel C DHVQFN 24, 20, 16, 14
	OM13494 Breakout board panel D HVQFN 14, 16, 20, 24
	OM13495 Breakout board panel E TSSOP 14, 16, 20, 24
OM13496 Breakout board panel F TSSOP28, XQFN16, QSOP16, XFBGA16	
OM13497 Breakout board panel G HTSSOP28, VFBGA24, XFBGA24	
I ² C-2005 board	OM6275 I ² C 2005-1 evaluation board
	OM6281 PCA9698 daughter card for I ² C 2005-1
	OM6282 PCA9633 daughter card for I ² C 2005-1
	OM6293 PCA9600 daughter card for I ² C 2005-1
LCD driver	OM6290 LCD driver evaluation board PCF8576D, PCF2119, PCF8531, PCA9633
	OM6292 PCA21125, PCF8562 demo board
	OM13500 PCA9620 demo board
	OM13500A PCF8537 and PCA8537 demo board
	OM13501 PCF8538 and PCA8538 demo board
	OM13501A PCF8538 and PCA8538 evaluation board
	OM13502 ¹⁾ PCA2117 demo board
OM13503 ¹⁾ PCA8539 demo board	
Touch and capacitive sensor	OM11056 2 x PCF8885 evaluation board 16-channel touch switch for design support
	OM11057 PCF8885/PCF8886 capacitive sensors and PCF8536 LCD/LED driver demoboard
	OM11057A OM11057 add-on board with high sensitivity slider
RTC	OM11059A PCF85063TP & PCF85063ATL evaluation board
	OM13510 PCF85263 evaluation board
	OM13511 PCF8523 evaluation board
	OM13513 PCF2127 & PCF2129AT evaluation board
	OM13514 PCF85363 evaluation board
OM13515 PCF85063AT evaluation board	

Demo boards	
USB	OM13518 USB-I ² C-bus dongle
Misc	OM6277 PCA9564 evaluation board
	OM13285 PCA9629 I ² C stepper motor demo board and kit
	OM13313 TDA5051A PLM demo board kit
	OM13314 TDA5051A Master/Slave lighting demo kit
Voltage level translator	OM13315 NVT2001GM demo board, single channel bi-directional voltage level translator
	OM13317 NVT2008PW demo board, 8-channel bi-directional voltage level translator
	OM13318 NVT2002DP demo board, dual channel bi-directional voltage level translator
	OM13319 NVT2003DP demo board, 3-channel bi-directional voltage level translator
	OM13323 NVT2006PW demo board, 6-channel bi-directional voltage level translator
	OM13324 NVT2010PW demo board, 10-channel bi-directional voltage level translator
LED driver	OM6282 PCA9633 LED dimmer 4-channel voltage switch demo board I ² C Fm+
	OM13269 PCA9632 LED 4-channel demo board
	OM13321 PCA9956B LED dimmer 24-channel constant current demo board I ² C Fm+
	OM13327 PCA9634 LED 8-channel demo board
	OM13329 PCA9952 demo board, LED dimmer 16-channel constant current demoboard I ² C Fm+ (with output enable)
	OM13330 PCA9955 demo board, LED dimmer 16-channel constant current demo board I ² C Fm+
	OM13332 PCA9685 demo board, 16-channel voltage source with 12-bit PWM demo board I ² C Fm+
	OM13333 PCA9635 demo board, 16-channel voltage source with 8-bit PWM demo board I ² C Fm+
OM13483 PCA9955B 16-channel I ² C Fm+ constant current LED driver demo board	
OM13528 PCA9532 16-channel LED dimmer voltage switch demo board	



OM11058
PCA/F8885 TFT touch demo board

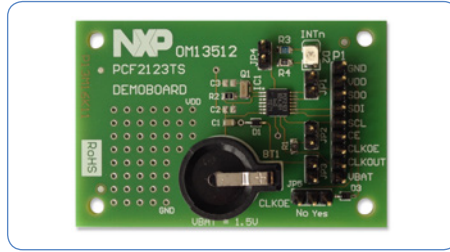

OM13512
PCF2123 SPI-bus RTC demo board

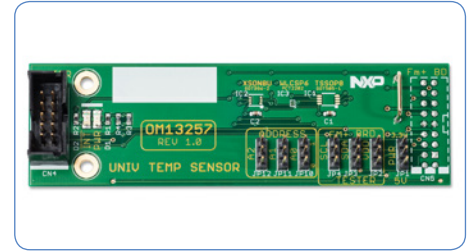

OM13257
Temp sensor daughter board

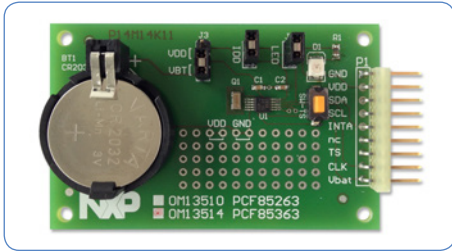

OM13514
PCF85363A I²C-bus RTC PCF85263/363 interface

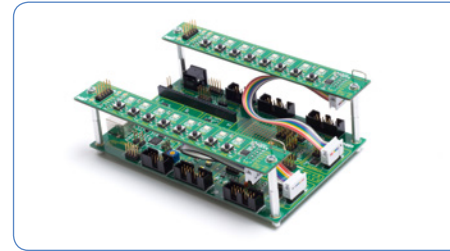

OM13320
Fm+ development board



OM13501
PCA85338 evaluation board



OM13518
Universal USB to I²C-bus RTC interface dongle

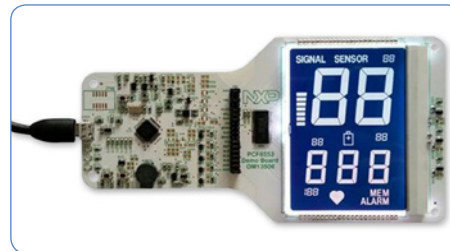

OM13506
LCD driver demo board

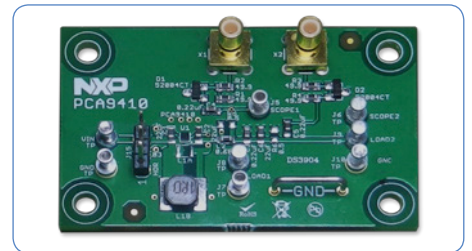

OM13570
PCA941x evaluation board

Our I²C-bus website (www.nxp.com/i2c) is a valuable resource for device information and training programs. It gives you direct access to a comprehensive handbook, application notes, information about evaluation kits and training materials, links to application and design support, and more. The I²C Fm+ development boards and daughter cards make it easy to program new peripherals and are a quick way to learn about the I²C-bus protocol.

www.nxp.com/i2c

© 2016 NXP Semiconductors N.V.
All rights reserved. Reproduction in whole or in part is prohibited without the prior written consent of the copyright owner. The information presented in this document does not form part of any quotation or contract, is believed to be accurate and reliable and may be changed without notice. No liability will be accepted by the publisher for any consequence of its use. Publication thereof does not convey nor imply any license under patent- or other industrial or intellectual property rights.